

# Performance Analysis of Solar-Based Wireless Charging Infrastructure for Electric Vehicles

Ajay Soni, Hina Thakre, Hitesh Chouksey, Krishna Kumar, Mohit Bunkar, Rahul Kada, Priyank Srivastava

Department of Electrical & Electronics Engineering Oriental College of Technology, Bhopal.

**Abstract-** The rapid growth of electric vehicles (EVs) has increased the demand for sustainable and convenient charging infrastructure. Conventional wired charging systems require physical connectors that suffer from wear, maintenance requirements, and user inconvenience. This paper proposes a Solar Wireless EV Charging System that combines solar photovoltaic generation with wireless power transfer technology. Solar energy is harvested using photovoltaic panels and stored in a battery bank through a charge controller. The stored energy is converted into high-frequency AC power using an inverter and transferred wirelessly through resonant inductive coupling. A receiver coil mounted on the electric vehicle captures the transmitted energy, which is rectified and used for battery charging. The proposed system reduces dependency on fossil-fuel-based electricity, enhances charging convenience, and promotes renewable energy utilization. The design improves safety by eliminating exposed charging cables and supports future smart transportation infrastructure. Performance factors such as coil alignment, transfer distance, efficiency, and energy management are discussed. The study concludes that integrating solar energy with wireless charging provides an environmentally friendly and practical solution for future electric mobility.

**Keywords-** Electric Vehicle, Wireless Charging, Solar Energy, Inductive Power Transfer, Renewable Energy.

## I. INTRODUCTION

Electric vehicles are becoming a major component of sustainable transportation systems. Growing concerns regarding air pollution, climate change, and fossil fuel depletion have accelerated EV adoption. Traditional charging methods rely on cables and charging stations, which may create inconvenience and maintenance challenges. Wireless charging technology enables contact less power transfer and enhances user comfort. Solar energy integration further reduces grid dependence and promotes clean energy usage.

## II. LITERATURE REVIEW

Researchers have investigated inductive power transfer, resonant coupling techniques, and renewable-energy-powered charging stations. Previous studies indicate that wireless charging can achieve high efficiency under proper alignment conditions.

Solar-powered charging infrastructure reduces operational costs and carbon emissions. Despite these advancements, integrated solar wireless EV charging systems require further

optimization in power management and energy transfer efficiency.

## III. PROBLEM STATEMENT

Existing EV charging systems depend heavily on grid electricity and wired connectors. Physical charging cables are susceptible to damage, weather exposure, and maintenance issues. Increasing EV penetration also creates stress on power distribution networks. A sustainable and user-friendly charging system is therefore necessary

## IV. PROPOSED METHODOLOGY

The proposed system includes solar panels, charge controller, battery bank, inverter, transmitter coil, receiver coil, rectifier circuit, and battery management system. Solar energy is collected and stored before being transferred wirelessly through resonant inductive coupling. The received power is conditioned and supplied to the EV battery.

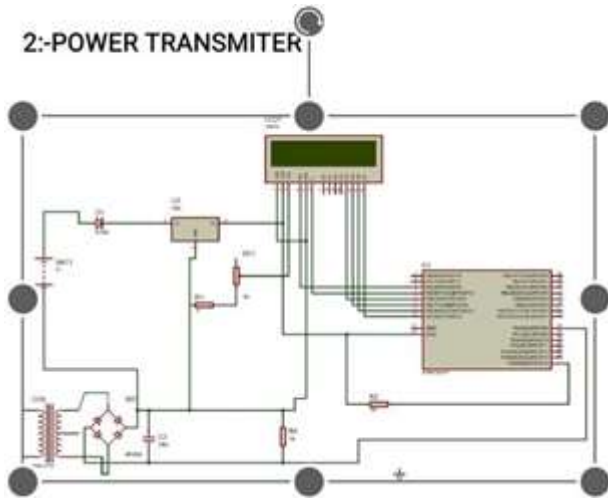

### V. SYSTEM ARCHITECTURE

The architecture consists of renewable energy generation, energy storage, power conditioning, wireless transfer, and battery charging units. The solar panel generates DC power, the battery bank stores energy, and the inverter generates high-frequency AC for wireless transmission. The receiving unit converts the energy back into usable DC power.

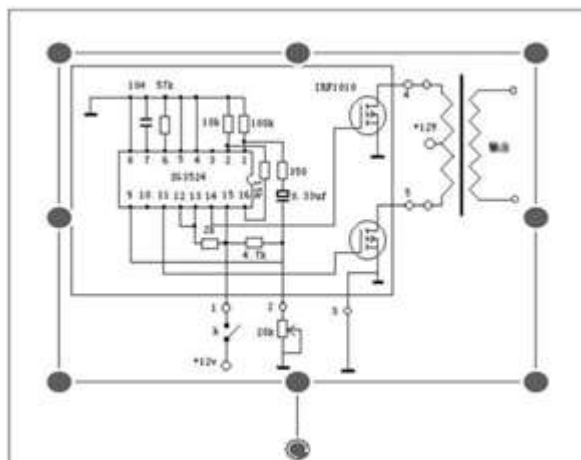

### VI. HARDWARE COMPONENTS

Solar panels, charge controllers, battery storage systems, high-frequency inverters, transmitting coils, receiving coils, rectifiers, filters, and battery management systems are used. Each component plays a vital role in ensuring efficient and reliable power transfer.

### ATmega328 Architecture

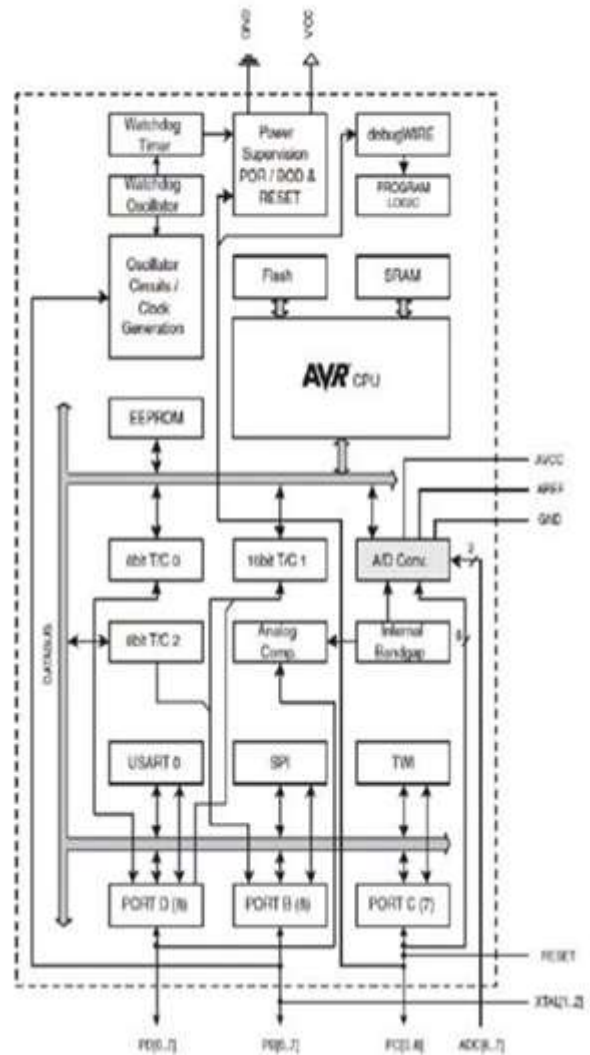

### VII. RESULTS AND DISCUSSION

Simulation and prototype studies indicate that charging efficiency depends on frequency selection, coil design, alignment accuracy, and transfer distance. Solar energy integration significantly reduces grid consumption and supports sustainable charging operations. The system demonstrates reliable charging performance under different operating conditions.

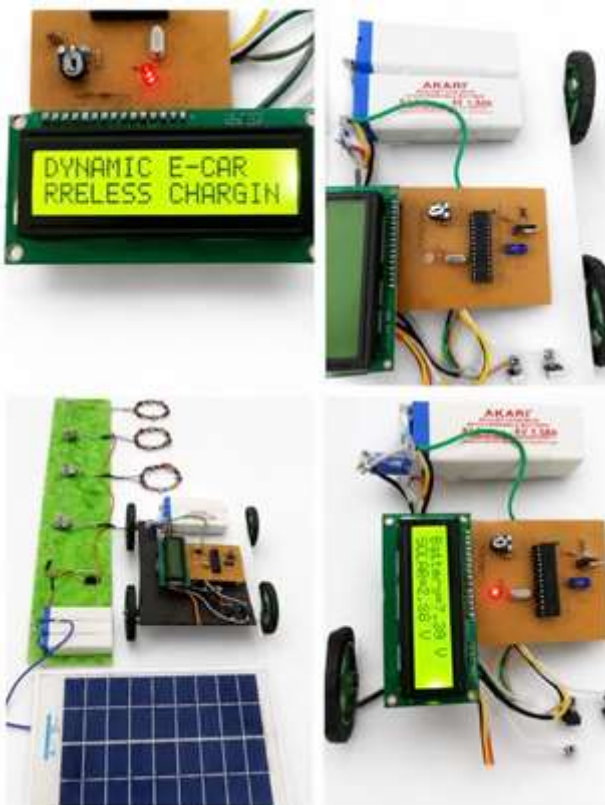

improving convenience and safety. It represents a promising technology for future smart transportation systems.

## REFERENCES

1. S.LiandC.C.Mi,'Wireless Power Transfer for Electric Vehicle Applications,' IEEE, 2015.
2. A. Ahmad et al., 'A Comprehensive Review of Wireless Charging Technologies for Electric Vehicles,' IEEE Access, 2018.
3. J.Miller,'Wireless Charging of Electric Vehicles,' IEEE Power Electronics Magazine, 2014

## VIII. ADVANTAGES AND LIMITATIONS

Advantages include renewable energy utilization, contactless charging, improved safety, reduced maintenance, and environmental sustainability. Limitations include higher installation cost, alignment sensitivity, and efficiency reduction with increasing air gap.

## IX. FUTURE SCOPE

Future developments may include dynamic wireless charging roads, IoT-based monitoring, artificial intelligence for energy optimization, and vehicle-to-rid integration. Improvements in battery technology and wireless power electronics will further enhance system performance.

## X. CONCLUSION

The Solar Wireless EV Charging System integrates renewable energy generation with wireless power transfer to create a sustainable EV charging solution. The proposed approach reduces reliance on conventional electricity sources while