

Design and Development of Unmanned Aerial Vehicle Using the Additive Manufacturing

Ravikumar PC, Bhuvan A H, Yashwanth KH, Manjunath SH Professor
Department of Mechanical Engineering, Adichunchanagiri university.

Abstract- Unmanned Aerial Vehicles (UAVs), commonly known as drones, have gained significant importance in various fields such as surveillance, agriculture, disaster management, environmental monitoring, and military operations. The design and development of UAVs require lightweight structures, high strength, aerodynamic efficiency, and cost-effective manufacturing techniques. Additive Manufacturing (AM), also known as 3D printing, has emerged as a revolutionary technology that enables rapid prototyping, complex geometrical designs, reduced material waste, and faster production cycles. This study focuses on the design and development of an Unmanned Aerial Vehicle using Additive Manufacturing techniques. The UAV components are designed using Computer-Aided Design (CAD) software and fabricated through 3D printing technology. The use of additive manufacturing allows the production of lightweight and customized parts while maintaining structural integrity and reducing overall manufacturing costs. The study evaluates the design process, material selection, fabrication methods, assembly procedures, and performance characteristics of the developed UAV.

Keywords- Unmanned Aerial Vehicle (UAV), Drone Technology, Additive Manufacturing, 3D Printing, Aerospace Engineering, UAV Design, UAV Development.

I. INTRODUCTION

Quadcopters, a type of unmanned aerial vehicle (UAV), are rotary-wing aircraft that use four rotors for lift and maneuverability. Unlike traditional helicopters that rely on a single main rotor and a tail rotor for stability, quadcopters achieve flight by varying the speed of each of their four propellers. Their simple design, stability, and maneuverability make them widely popular for applications ranging from aerial photography to military surveillance and autonomous deliveries.

In recent years, the integration of additive manufacturing (AM)—commonly known as 3D printing—has brought a transformational shift in the design and fabrication of UAVs. Additive manufacturing enables rapid prototyping, lightweight structures, complex geometries, and customizable designs that are difficult or impossible to achieve with conventional manufacturing methods. This makes AM an ideal technology for UAV development, where weight reduction, structural strength, and design flexibility are critical performance factors.

The ability to fabricate components layer-by-layer allows engineers to optimize the quadcopter frame, propeller housings,

battery mounts, sensor enclosures, and other structural parts with high precision and reduced material wastage. Moreover, AM technology shortens development cycles, allowing quick design iterations and testing—an essential advantage in academic research, aerospace engineering, and modern product development environments.

As UAV applications continue to expand into agriculture, disaster management, environmental monitoring, logistics, and defence, the need for cost-effective, lightweight, and efficient aerial platforms is increasing. Designing and fabricating a UAV using additive manufacturing addresses this demand by combining aeronautical engineering principles with advanced digital manufacturing techniques. This project aims to explore the complete process—from conceptual design and CAD modelling to material selection, 3D printing, assembly, and performance testing—resulting in a fully functional, additively manufactured quadcopter.

Basic Structure and Working Principle

A quadcopter consists of four main rotors arranged in a square or "X" configuration. Two rotors spin clockwise, while the other two spin counterclockwise, balancing the torque and enabling stable flight. The simplified diagram is given in the figure 1 and various motions are given in figure 2.

By independently varying the speed of each rotor, a quadcopter can perform multiple controlled maneuvers in three-dimensional space. These motions are governed by fundamental aerodynamic principles:

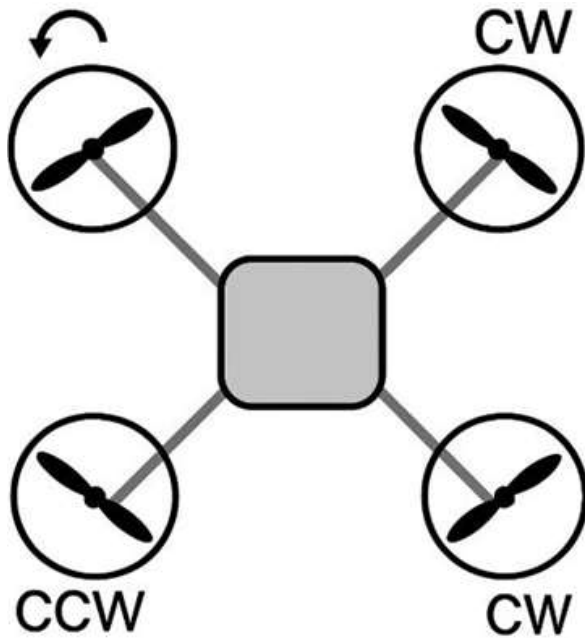

Figure 1: Rotor directions and Various motions in drone.

1. Ascend / Descend

Vertical movement is controlled by increasing or decreasing the speed of all four rotors simultaneously.

- Increasing rotor speeds → higher lift → ascending motion
- Decreasing rotor speeds → reduced lift → descending motion

2. Pitch (Forward and Backward Motion)

Pitching involves tilting the quadcopter along its lateral axis:

- To move forward, the rear rotors speed up while the front rotors slow down.
- To move backward, the front rotors speed up and the rear rotors slow down.

3. Roll (Left and Right Movement)

Roll motion is produced by tilting the quadcopter sideways:

- To roll right, the rotors on the left run at higher speed while the right rotors slow down.
- To roll left, the right-side rotors speed up and the left-side rotors slow down.

4. Yaw (Rotational Motion)

Yawing rotates the quadcopter about its vertical axis. This rotation is generated by controlling the relative thrust between the CW and CCW rotating rotors:

Increasing the speed of one diagonal rotor pair while decreasing the speed of the other pair causes left or right rotational motion.

In Figure 2, the motion control is visually represented where red-colored rotors indicate higher speeds, and green-colored rotors indicate lower speeds.

- (a) Throttle adjusts vertical movement (up/down).
- (b) Roll enables left or right tilting.
- (c) Pitch controls forward and backward movement.
- (d) Yaw allows rotational change in heading.

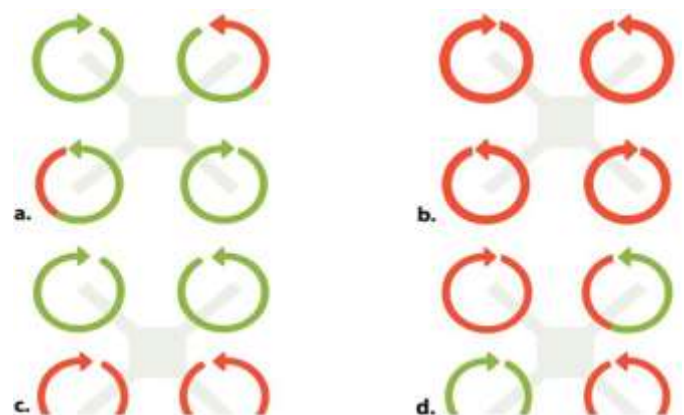

Figure 2: Motion control in Quadcopter.

II. LITERATURE SURVEY

The field of drone design has rapidly evolved over the past few decades, driven by advancements in aerodynamics, propulsion systems, materials, and artificial intelligence. This literature review explores key developments in drone design, focusing on aerodynamics, propulsion, structural materials, and control systems

Aerodynamics and Flight Dynamics

Aerodynamics plays a critical role in drone efficiency, stability, and maneuverability. Studies such as Anderson (1) provide foundational insights into the principles of aerodynamics applied to unmanned aerial vehicles (UAVs). Research by Mueller et al. (1) explores optimized airfoil designs for improved lift-to-drag ratios, essential for energy-efficient flight. Further, studies on biomimicry, such as the work of Shyy et al. (1), demonstrate how natural flyers inspire novel wing configurations for drones, including flapping-wing and morphing-wing designs.

Propulsion Systems

The selection of propulsion systems significantly affects drone performance, endurance, and noise levels. Traditional electric motor-driven propellers remain the standard for most drones, as discussed by Brandt & Gilliam (3). Recent advancements in hybrid propulsion systems, such as fuel cell-powered drones studied by Lapeña-Rey et al. (3), extend flight duration while reducing carbon footprints. Additionally, research into distributed propulsion concepts, such as ducted fan configurations (Kim et al., 3), offers improved thrust efficiency and noise reduction.

Structural Materials and Lightweight Design

The development of lightweight yet durable materials is crucial for enhancing drone payload capacity and energy efficiency. Carbon fiber composites, as examined in studies by Tsai & Hahn, offer high strength-to-weight ratios and improved structural integrity. Furthermore, advancements in 3D-printed drone components, explored by Mohd Jani et al. (8), allow for prototyping and customization, reducing production costs and increasing design flexibility.

Autonomous Navigation and Control Systems

Control systems are fundamental to drone operation, enabling stability, obstacle avoidance, and autonomous flight. Classical control theories, including PID controllers, remain widely used, as highlighted in Beard & McLain (2). However, recent research emphasizes AI-driven navigation, such as deep learning-based obstacle avoidance algorithms by Giusti et al. (2). Additionally, the integration of GPS-denied navigation systems, including visual-inertial odometry (Forster et al., 2), enhances drone usability in indoor and complex environments. The literature on drone design underscores continuous advancements across multiple domains. Future research directions include further miniaturization of components, enhanced AI-driven flight control, and alternative energy sources to improve sustainability. The integration of these innovations will contribute to the development of next-generation UAVs with greater efficiency, adaptability, and autonomy.

Ducted fan unmanned aerial vehicles (UAVs)

Ducted fan unmanned aerial vehicles (UAVs) have gained significant research attention due to their compact design, inherent safety, and improved aerodynamic efficiency over traditional open-rotor configurations. The study by Kim, Kim, and Kim (6) focuses on addressing long-standing challenges

associated with ducted fan propulsion, including flow separation, thrust losses, and stability issues during hovering and forward flight.

Early research on ducted fan systems emphasized their potential to enhance thrust by reducing tip vortices and improving pressure distribution across the rotor disk. However, limitations such as boundary-layer separation and inlet distortion often reduced actual performance gains. Kim et al. (6) contribute to this body of work by developing a refined duct-rotor interaction model and validating it with experimental prototypes. Their findings show that optimized duct geometries—particularly those with carefully shaped lips and internal curvature—can significantly improve thrust efficiency while also contributing to better flow stability.

Hybrid fuel cell systems have emerged as a promising power source for unmanned aerial vehicles (UAVs)

Hybrid fuel cell systems have emerged as a promising power source for unmanned aerial vehicles (UAVs), aiming to overcome the limited endurance of battery-powered platforms while avoiding the emissions and noise associated with combustion engines. Lapeña-Rey, Walker, and Smith (10) investigate the integration of hybrid fuel cell architectures designed specifically to enhance UAV operational performance, focusing on endurance, reliability, and energy density.

Earlier research on UAV energy systems highlighted the constraints of lithium-ion batteries, particularly their low specific energy (150–250 Wh/kg) which restricts flight time. Fuel cells, particularly proton exchange membrane (PEM) systems, provide higher specific energy and cleaner operation. However, standalone fuel cells struggle with transient load response and peak power demands during takeoff and maneuvering. Lapeña-Rey et al. (10) address this gap by proposing a hybrid configuration combining fuel cells with batteries or supercapacitors to exploit the strengths of both technologies.

III. COMPARISONS

Drone Configurations Comparison

Feature	Quadcopter	Hexacopter	Octocopter
Motors	4	6	8
Cost	Low	Medium	High

Lift Capacity	Moderate	High	Very High
Stability	Good	Very Good	Excellent
Redundancy	None (motor failure causes crash)	Partial	High
Uses	Hobby, photography	Agriculture, mapping	Heavy lifting, cinematography

and-place operations. However, designing a cost-effective and lightweight drone capable of carrying a moderate payload over a practical distance remains a significant engineering challenge. Traditional fabrication methods often increase the weight and structural complexity of drones, reducing their payload capacity, flight efficiency, and battery endurance.

Component Comparison (Motors)

KV Rating	Propeller Size	Best For	Advantages	Drawbacks
High KV (1500–2600)	Smaller props	Racing	Fast response	Less torque
Medium KV (900–1400)	Medium props	General drones	Balanced	Average lift
Low KV (700–900)	Large props	Payload/Photo	High torque	Slower RPM

To address these limitations, the present project focuses on designing and fabricating a quadcopter using additive manufacturing technology. The goal is to create an optimized, lightweight frame capable of carrying a payload of 500 grams and transporting it over a distance of 1–5 kilometers, while ensuring stable flight, energy efficiency, and reliable control. This requires careful consideration of structural design, propulsion systems, battery selection, motor performance, and overall weight distribution. The problem lies in achieving the required payload capability and flight range without compromising on stability, durability, and manufacturability.

Battery Comparison

Battery Type	Voltage	Advantages	Disadvantages
3S LiPo	11.1V	Good for beginners	Lower thrust
4S LiPo	14.8V	Balance of power	Heavier
6S LiPo	22.2V	Maximum performance	Expensive

Objectives

The main objectives of the project “Design, Fabrication, and Evaluation of a UAV Using Additive Manufacturing Technology” are as follows:

1. To design a lightweight, aerodynamically efficient UAV frame using CAD tools suitable for additive manufacturing.
2. To fabricate the UAV frame using advanced additive manufacturing techniques to achieve reduced weight, improved structural strength, and cost-effective production.
3. To select and integrate appropriate propulsion, power, and control system components required for stable and efficient UAV operation.
4. To evaluate the UAV’s structural integrity, flight stability, and performance under various operational conditions.
5. To assess the UAV’s ability to carry a payload of up to 500 grams over a distance of 1–5 km for pick-and-place applications.
6. To analyze the efficiency of additive manufacturing in terms of material usage, customization flexibility, and overall UAV performance.
7. To perform testing, calibration, and validation of the UAV to ensure safety, reliability, and mission compatibility.
8. To document the complete design-to-fabrication workflow and performance results for future optimization and research.

Manual vs Autonomous Drone Comparison

Feature	Manual Drone	Autonomous Drone
Control	Remote pilot	AI/GPS based
Accuracy	Depends on skill	Very high
Applications	Racing, hobby	Delivery, mapping
Complexity	Low	High
Safety	Medium	High (failsafes)

Sensor Comparison

Sensor Type	Function	Use Case
IMU (Gyro + Acc)	Stabilization	Basic flight
GPS	Navigation	Waypoint missions
Barometer	Altitude hold	Autonomous flight
LiDAR/Ultrasonic	Obstacle avoidance	Indoor/outdoor flight
Compass	Direction	Return to home

IV. PROBLEM DEFINITION & OBJECTIVES

Problem Definition

Unmanned Aerial Vehicles (UAVs) are increasingly being used for tasks such as logistics, surveillance, and automated pick-

V. APPLICATIONS/ADVANTAGES/ DISADVANTAGES

Applications

Quadcopters have rapidly evolved from simple hobbyist devices into sophisticated aerial platforms with applications across numerous sectors. Their ability to hover, perform vertical take-off and landing (VTOL), navigate through challenging environments, capture real-time data, and carry diverse payloads has made them indispensable in both civilian and industrial domains. The integration of advanced technologies such as GPS, inertial measurement units (IMUs), high-resolution cameras, thermal sensors, and artificial intelligence has further expanded their capabilities. This section elaborates on the wide-ranging applications of quadcopters, providing an in-depth understanding of their significance in modern industries.

1. Aerial Photography and Videography

One of the most prominent and commercially successful applications of quadcopters is in aerial imaging. Equipped with stabilized gimbal-mounted cameras, quadcopters enable photographers, filmmakers, and media professionals to capture high-resolution images and cinematic shots from unique aerial perspectives.

Quadcopters have transformed the media and film industry by reducing the need for helicopters or cranes, offering a cost-effective, safe, and flexible solution for capturing aerial footage. Professional-grade drones support features like GPS-assisted flight, autofocus, panoramic imaging, and automated flight paths (waypoint navigation), making aerial cinematography easy even for non-experts.

- **Applications include:**

- Film and television production
- Wedding photography
- Real estate marketing
- Environmental documentation
- Social media content creation

Their ability to hover steadily allows capturing long-exposure and time-lapse shots that were previously difficult.

Surveillance and Security

Quadcopters are increasingly used for military, industrial, and civilian surveillance due to their ability to cover large areas

quickly and operate in inaccessible regions. Equipped with night-vision cameras, infrared sensors, and thermal imaging systems, quadcopters support:

- Military reconnaissance
- Border patrolling
- Traffic monitoring and management
- Crowd surveillance during public events
- Industrial site inspection

Security forces deploy UAVs to gather visual intelligence without putting personnel at risk. Law enforcement agencies also utilize quadcopters to track suspects, monitor riots, and assist in crime-scene assessment.

Advanced quadcopters integrated with AI-based image recognition systems can detect suspicious activities, monitor restricted areas, and automatically alert authorities, making them highly effective tools for maintaining public safety.

3. Agriculture and Farming

In the agricultural sector, quadcopters play a crucial role in enabling precision farming, a technique that optimizes resource usage and improves crop yield. Equipped with multispectral, thermal, and RGB cameras, UAVs help farmers gather data on:

- Crop health and disease detection
- Soil moisture levels
- Nutrient distribution
- Plant growth patterns
- Field mapping and planning

Quadcopters are also used for pesticide and fertilizer spraying, providing uniform distribution and minimizing human exposure to chemicals. They cover large agricultural fields efficiently and reduce labor requirements. Companies now offer drones capable of spraying 10–20 liters of liquid per flight, making them suitable for small and medium-sized farms.

Additionally, UAVs assist in livestock monitoring, water resource assessment, and detecting irrigation problems, contributing to sustainable agricultural practices.

4. Logistics and Delivery Services

The use of quadcopters for logistics is rapidly gaining attention as companies experiment with autonomous delivery solutions. Organizations such as Amazon Prime Air, Google Wing, and Zipline are testing or deploying drones for

- Delivery of household items

- Medical supplies (blood packets, vaccines, medicines)
- Emergency packages during natural disasters
- Food delivery in urban environments

Quadcopters offer faster delivery times, reduced road congestion, and lower carbon footprints compared to conventional transportation. Zipline, for example, has successfully operated drone-based medical delivery networks in Rwanda and Ghana, significantly improving rural healthcare accessibility.

These systems rely on advanced navigation, obstacle detection, and autonomous flight control, making quadcopters an essential component of future smart logistics systems.

5. Search and Rescue Operations

- Locating missing persons using thermal imaging
- Assessing structural damage
- Delivering emergency supplies to stranded individuals
- Mapping disaster zones for rescue planning

Their ability to fly at low altitudes, maneuver through narrow spaces, and operate without runway requirements makes them ideal for rapid deployment. Firefighters use drones to analyze fire patterns and locate hotspots, ensuring efficient firefighting strategies. In mountain or forest rescue missions, quadcopters significantly reduce the time required for reconnaissance and increase the chances of survival for missing individuals.

6. Recreation, Sports, and Drone Racing

Quadcopters have become immensely popular in the recreational sector. Hobbyists use them for casual flying, learning aerodynamics, and exploring aerial perspectives. A rapidly growing sport, drone racing, has emerged worldwide, where pilots use high-speed first-person-view (FPV) quadcopters to compete on obstacle-filled tracks.

Features include:

- Lightweight carbon fiber frames
- High-speed brushless motors
- FPV goggles for immersive control
- Real-time video transmission

Drone racing competitions, such as those organized by the Drone Racing League (DRL), showcase advanced UAV technology and attract global audiences. Moreover, recreational quadcopters are widely used in academic projects, robotics competitions, and STEM education to teach students about control systems, kinematics, and embedded electronics.

7. Infrastructure Inspection and Maintenance

- Power transmission lines
- Wind turbines
- Bridges
- Railways
- Towers and antennas
- Roofs and building exteriors

Traditional inspection methods involve significant risk and require trained personnel to work at height. Quadcopters equipped with high-resolution or thermal cameras can safely capture detailed images, detect cracks, corrosion, and overheating components, and reduce inspection time and cost. AI-based defect detection further enhances inspection accuracy, making drones integral in predictive maintenance strategies.

8. Environmental Monitoring and Conservation

- Forest mapping
- Wildlife monitoring
- Air quality measurement
- Water pollution assessment
- Glacier and coastal studies

Quadcopters allow real-time data collection with minimal disturbance to natural ecosystems. In wildlife conservation, they help track endangered species, prevent poaching, and collect biological data from remote regions.

9. Construction and Land Surveying

In the construction industry, quadcopters are used for:

- Land surveying and topographic mapping
- 3D modeling of construction sites
- Progress monitoring
- Material estimation
- Site safety inspection

Using photogrammetry, drones generate accurate 3D maps and digital elevation models (DEMs), improving planning accuracy and project efficiency. They reduce labor-intensive surveying and allow real-time project tracking.

Advantages

1. Improved Stability and Flight Performance

Modern quadcopters benefit from:

- Advanced flight controllers
- Gyro stabilization
- IMU (Inertial Measurement Unit) sensors
- GPS-assisted hovering

- Machine-learning–based control algorithms These advancements provide:
- Highly stable flight even in windy environments
- Smoother aerial maneuvers
- Faster response to user commands
- Precise hovering accuracy

As a result, quadcopters can perform complex tasks such as mapping, inspection, and cinematography with minimal vibrations and drift.

2. Enhanced Autonomous Capabilities

One of the biggest advantages of modern technology is increased autonomy.

Quadcopters can now perform operations without continuous human control, thanks to:

- AI-based decision-making
- GPS/GLONASS/Galileo navigation
- Obstacle avoidance systems
- SLAM (Simultaneous Localization and Mapping)
- Real-time object detection and tracking Autonomous features enable:
- Automatic take-off and landing
- Pre-programmed waypoint navigation
- Self-return during low battery
- Autonomous surveillance and mapping
- Indoor navigation without GPS

This significantly reduces operator workload and errors, enabling even beginners to fly complex missions safely.

3. Higher Payload Capacity and Efficiency

Technological improvements in motors, ESCs, carbon-fiber frames, and battery systems allow quadcopters to carry heavier payloads with better efficiency.

This leads to:

- Powerful brushless motors
- Enhanced thrust-to-weight ratio
- Longer-lasting high-energy-density batteries Advantages include:
- Ability to carry high-resolution cameras
- Delivery of medical supplies or goods
- Deployment of sensors (thermal, LiDAR, multispectral)
- Greater flexibility for industrial applications

Better payload capabilities expand the range of tasks quadcopters can perform across industries.

4. Superior Imaging and Data Collection

Modern quadcopters are equipped with:

- 4K/8K ultra-HD cameras
- Thermal imaging sensors
- LiDAR scanners
- Multispectral and hyperspectral cameras
- Real-time data transmission systems These technologies offer:
- Detailed aerial mapping
- High-quality cinematography
- Accurate land surveys
- Crop health monitoring
- Night-time or low-light surveillance

Such advancements make quadcopters indispensable tools in agriculture, construction, disaster management, and environmental monitoring.

5. Longer Flight Time and Improved Battery Efficiency

New developments in:

- Lithium-polymer (LiPo) batteries
- Lithium-sulfur and solid-state battery technology
- Optimized power-management systems have led to:
- Longer flight endurance
- Faster charging times
- Reduced battery degradation

Although sensor load consumes power, improved battery density and energy management ensure better overall performance than earlier drone models.

6. Better Safety and Collision Prevention

Modern quadcopters incorporate multiple safety systems such as:

- Obstacle avoidance sensors (IR, ultrasonic, LiDAR)
- Return-to-home (RTH)
- Geo-fencing
- Failsafe motor cut-off
- Redundant flight controllers These enhancements:
- Prevent mid-air collisions
- Reduce chances of crashing
- Increase operational safety in crowded environments

As safety features advance, quadcopters become more reliable for sensitive missions such as rescue operations and inspection of high-risk areas.

7. Increased Range and Connectivity

With the integration of improved communication technology:

- 5G and 6G-ready modules
- High-frequency transmission systems
- Low-latency control links
- Enhanced FPV (First-Person View) systems quadcopters now support:
- Longer operational range
- Real-time HD video transmission
- Secure data transfer
- Better control responsiveness

These connectivity improvements make up modern drone swarms, remote inspections, and industrial monitoring missions.

8. Cost Reduction in Long-Term Operations

Although advanced drones have higher upfront costs, technological progress leads to long-term savings due to:

- Fewer mechanical failures
- Longer component lifespans
- Efficient maintenance
- Ability to replace expensive manual labor

For industries like agriculture, mining, construction, and logistics, drones reduce operational time and human workforce, lowering overall expenses.

9. Expanded Industrial and Commercial Applications

With continuous improvements, quadcopters now support critical applications such as:

- Precision agriculture
- Disaster response
- Medical/drug delivery
- Traffic monitoring
- Pipeline and power-line inspection
- Cinematography and surveying
- Environmental conservation

New sensors and autonomous systems allow them to function in places where human access is difficult or dangerous.

Improved User Accessibility

Technological advancements have made drones:

- Easier to fly
- More beginner-friendly
- Safer for public use

Features like auto-stabilization, one-touch take-off, GPS hold, and AI-assisted navigation make quadcopters accessible to students, hobbyists, and professionals alike.

Disadvantages

While advancements in quadcopter technology—such as AI-assisted navigation, machine learning-based autonomy, improved sensors, and efficient power systems—have significantly enhanced drone performance, they also introduce several challenges and disadvantages. These drawbacks must be considered to ensure responsible use, safe operation, and sustainable development of UAV systems.

Increased Complexity in Design and Operation

Modern quadcopters integrate advanced components like LiDAR, multi-GNSS navigation, onboard AI processors, and real-time obstacle-avoidance systems.

While these features improve performance, they also lead to:

- More complicated assembly and configuration
- Higher likelihood of technical failures
- Requirement for skilled operators
- Increased learning curve for users and students

Traditional drones could be flown with simple transmitters, but modern drones require firmware updates, calibration, and sensor alignment before every flight.

2. Higher Manufacturing and Maintenance Costs

Advanced drones incorporate:

- High-resolution cameras (4K/8K)
- High-speed processors
- Intelligent batteries
- Redundant systems
- Stronger and expensive materials (carbon fiber, polymer composites)
- Initial manufacturing cost
- Cost of repair and spare parts
- Routine maintenance expenses

A crash involving an advanced drone results in much greater financial loss compared to simple hobby-grade quadcopters.

3. Shorter Flight Time Due to Additional Sensors

Although battery technology is improving, the number of sensors and processing units in modern drones continues to grow.

Components such as AI chips, HD cameras, GPS, ultrasonic sensors, and gimbal motors draw substantial power, which results in

- Reduced effective flight time
- Higher battery consumption
- Need for multiple backup batteries

Thus, the operational endurance of advanced drones may not significantly improve even with better batteries.

6. Advancements

Quadcopter technology has witnessed remarkable growth over the last decade, driven by innovations in artificial intelligence (AI), machine learning (ML), sensor integration, embedded systems, and materials engineering. Modern quadcopters are no longer simple remote-controlled devices; they have evolved into sophisticated autonomous aerial platforms capable of performing complex tasks with high accuracy and minimal human intervention. These advancements are transforming sectors ranging from defense and agriculture to logistics, healthcare, and environmental management. This section discusses the major technological developments that have shaped the current and future landscape of quadcopters.

a. Integration of Artificial Intelligence and Machine Learning

One of the most significant advancements in quadcopter technology is the incorporation of AI and ML algorithms. These capabilities enable drones to perceive their environment, make intelligent decisions, and adapt to changing conditions in real time.

• Autonomous Navigation

Through AI-driven path-planning algorithms, quadcopters can autonomously plan routes, avoid obstacles, and reach target locations without manual control. Techniques such as SLAM (Simultaneous Localization and Mapping) allow drones to map unknown environments and navigate efficiently.

b. Computer Vision

Machine learning models trained on large datasets enable quadcopters to interpret and analyze visual information, supporting applications like:

- Object detection
- Human recognition
- Terrain mapping
- Target tracking
- Gesture-based control

Advanced deep learning networks make drones capable of detecting anomalies, identifying crops, or recognizing emergency signals, making them indispensable in agricultural and surveillance sectors.

c. Intelligent Decision-Making

Reinforcement learning algorithms allow quadcopters to optimize flight patterns, improve energy consumption, enhance task execution, and adapt to dynamic obstacles or weather conditions. As a result, modern UAVs exhibit higher autonomy and reliability than earlier models.

Improvements in Battery Technology and Power Systems

Power limitations remain a major challenge in UAV design. However, significant progress has been made in battery efficiency, smart power management, and lightweight energy storage materials.

a. Li-ion and Li-Po Battery Advancements

Lithium-ion and lithium-polymer batteries have become the industry standard due to:

- Higher energy density
- Faster charging
- Better discharge rates
- Lower weight

Recent improvements in anode and cathode materials (like silicon-based anodes and graphene-enhanced electrodes) have increased flight times and payload-carrying capacity.

b. Hybrid Power Systems

Some quadcopters now use hybrid systems combining:

- Fuel cells
- Solar panels
- Supercapacitors
- Traditional batteries

These systems extend operational time significantly, enabling long-duration missions such as border patrolling and environmental monitoring.

c. Power Optimization Algorithms

AI-based battery management systems (BMS) can monitor cell performance, predict battery health, and optimize energy consumption by adjusting motor response and sensor usage.

Advanced Sensors and Real-Time Data Processing

Modern quadcopters rely on an ecosystem of advanced sensors and computational modules to operate autonomously and safely.

a. Global Positioning System (GPS/GNSS)

High-precision GNSS modules provide accurate positioning, supporting waypoint navigation, autonomous return-to-home features, and geofencing.

b. Inertial Measurement Units (IMU)

IMUs combine accelerometers, gyroscopes, and magnetometers to measure orientation, enabling stable flight control even in windy conditions.

c. LIDAR, Radar, and Vision Sensors

These sensors are used for:

- 3D environment mapping
- Detecting obstacles
- Estimating distance
- Performing autonomous landings

LIDAR-based drones are especially effective in construction, forestry, and mining applications due to their ability to generate high-resolution elevation models.

d. Onboard Edge Processing

Modern quadcopters use powerful processors (NVIDIA Jetson, Raspberry Pi, PX4, STM32, Qualcomm Flight platforms) that support onboard AI inference, allowing real-time:

- Object tracking
- Data analysis
- Automated decision-making
- Sensor fusion

This reduces dependence on remote servers, making drones more efficient and secure.

Enhanced Communication Technologies

Reliable communication is essential for long-range control and data transfer. Recent advancements include:

a. 5G and Beyond

5G allows:

- Low-latency communication
- Real-time HD video streaming
- Cloud-assisted navigation

- Swarm coordination

This is crucial for delivery drones and urban air mobility systems.

b. Long-Range Radio Systems

Protocols like LoRa, LTE, and advanced RF modules provide stable communication for missions requiring long-distance surveillance.

c. Satellite-Based Connectivity

For remote and maritime operations, drones use satellite communication systems that ensure uninterrupted communication, even beyond line of sight.

Swarm Technology and Multi-UAV Coordination

Swarm technology allows multiple quadcopters to work together as a coordinated unit.

Inspired by natural systems like bird flocks and bee colonies, swarming enables:

- Cooperative surveillance
- Distributed environmental monitoring
- Search and rescue in large geographical areas
- Coordinated mapping
- Multi-drone delivery networks

Using AI algorithms, each drone communicates with others in the swarm, sharing data and adjusting positions dynamically to avoid collisions and optimize task distribution.

This technology is rapidly advancing using principles from robotics, control theory, and distributed artificial intelligence.

Improvements in Structural Design Through Additive Manufacturing

Additive manufacturing (AM) has significantly contributed to the evolution of quadcopter design.

a. Lightweight Structures

3D-printed parts made from PLA, PETG, ABS, carbon-fiber-infused composites, and nylon contribute to:

- Weight reduction
- Higher flight efficiency
- Improved payload capacity

b. Complex Geometries

AM enables fabrication of intricate shapes optimized for aerodynamics and strength, such as:

- Honeycomb structures

- Custom motor mounts
- Shock-absorbing landing gear

c. Rapid Prototyping

Design iterations can be quickly printed and tested, enabling faster development cycles for research and product innovation.

Obstacle Avoidance and Safety Mechanisms

Modern quadcopters incorporate advanced safety mechanisms that make autonomous operations more reliable.

a. Obstacle Avoidance

Using ultrasonic sensors, stereo cameras, infrared sensors, and LIDAR, drones can detect and avoid:

- Trees
- Buildings
- Power lines
- Moving objects

b. Redundant Flight Systems

High-end drones include:

- Backup IMUs
- Failsafe landing protocols
- Dual GPS modules
- Automatic emergency return

These systems protect the drone during signal loss or unexpected failures.

c. Geofencing and No-Fly Zones

Software-based geofencing prevents drones from entering restricted or hazardous airspace, improving safety for both air traffic and ground personnel.

Software Ecosystems and Intelligent Flight Control Systems

Flight software has advanced significantly, with open-source platforms such as PX4, ArduPilot, and commercial systems like DJI Flight Controller offering:

- Tunable PID control
- Autonomous mission planning
- Real-time telemetry
- Cloud-based data analysis
- Simulation environments for testing

Software advancements have enabled even beginner users to operate quadcopters with high precision and reliability.

Future Trends in Quadcopter Technology

The future of quadcopters will be shaped by continuous advancements in robotics, materials, communication, and autonomy.

Expected future developments include:

- Fully autonomous delivery networks
- AI-powered urban traffic monitoring
- Long-endurance solar-powered drones
- Integration with smart cities and IoT infrastructure
- Human-carrying quadcopter taxis (urban air mobility)
- Self-repairing or self-diagnosing UAV systems

These trends indicate that quadcopters will play a major role in future transportation, logistics, and environmental management systems.

VII. DESIGN AND FABRICATION

The design and fabrication of a quadcopter involve integrating multiple mechanical, electrical, and software subsystems into a unified aerial platform capable of stable, controlled, and efficient flight. A quadcopter’s performance is determined by the careful selection, arrangement, and tuning of its components. These components can be broadly classified into structural systems, propulsion systems, power systems, control systems, and navigation/communication systems. Each subsystem plays a vital role in ensuring smooth flight dynamics, durability, and mission-oriented functionality. The following section provides an in-depth analysis of the various components and systems used in quadcopter construction.

Design Arm holder

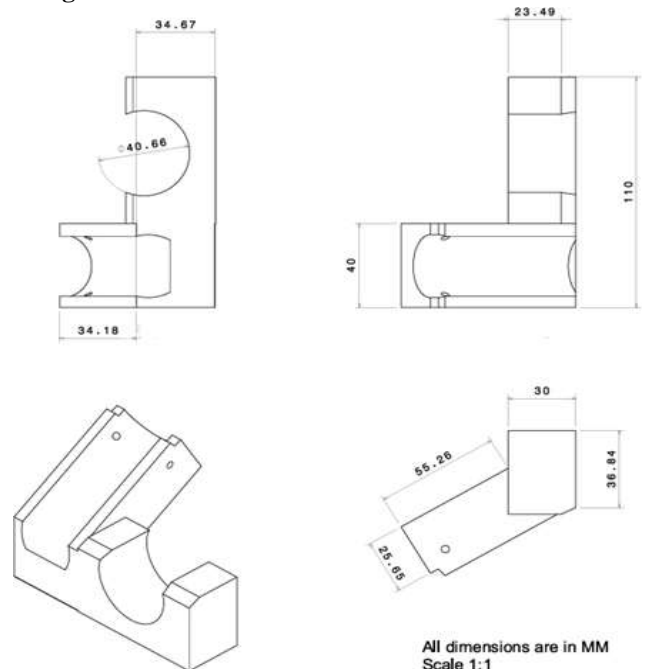

Bottom plate

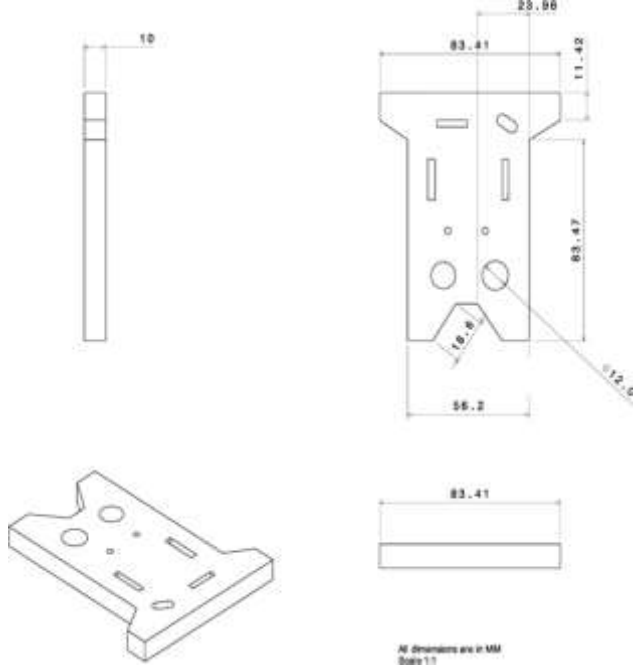

Arm Guide

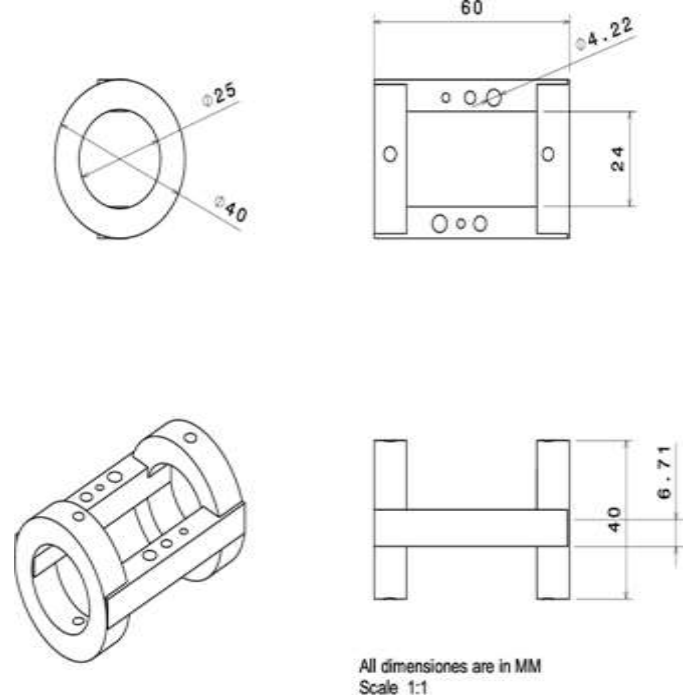

Top plate

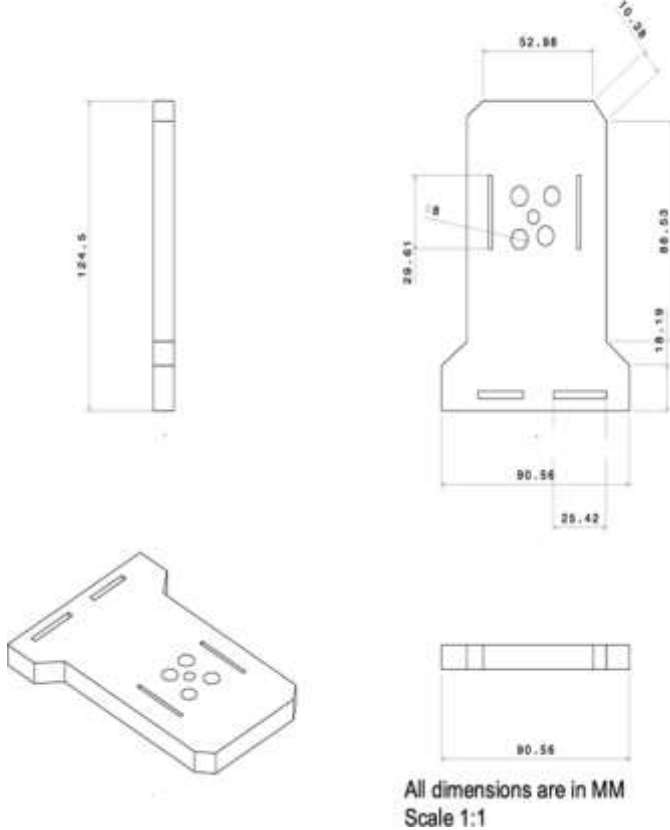

Motor Holder

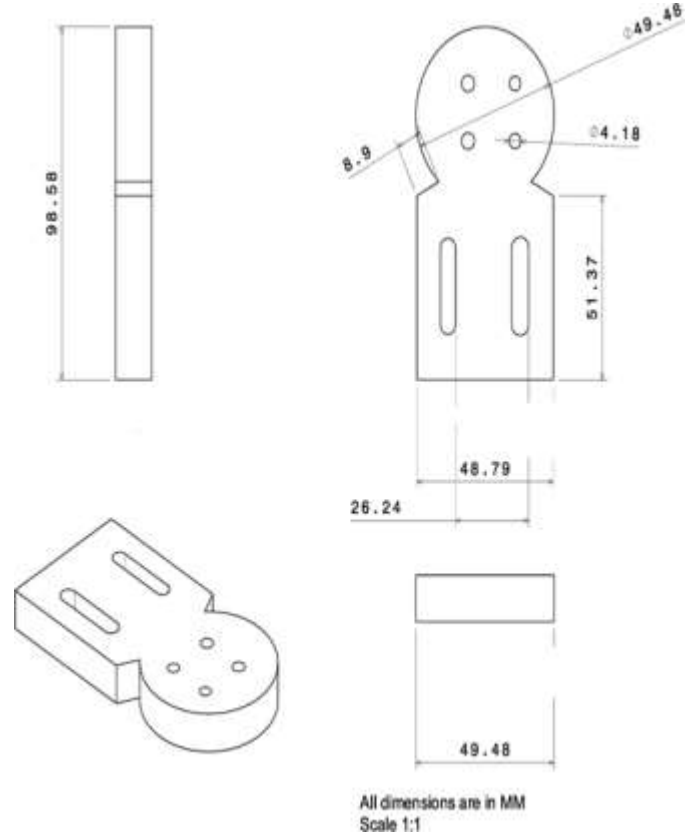

Arm tube

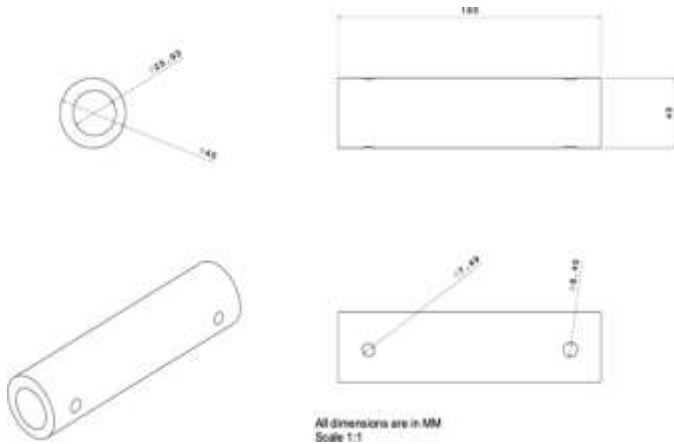

Propellers vary in:

- Diameter (5" to 15")
 - Pitch angle
 - Blade count (2-blade for stability; 3-blade or 4-blade for agility)
 - Materials (plastic, carbon fiber, nylon composite)
- Larger and higher-pitch propellers generate more thrust but consume more power, affecting flight efficiency.

b. Electronic Speed Controllers (ESCs)



Various purchased Components and Systems in a Quadcopter

a. Motors (Brushless DC Motors – BLDC)



ESCs link the flight controller to the motors, translating control signals into precise motor speeds.

ESC capabilities include:

- Fast response through PWM or DShot protocols
 - Overcurrent and thermal protection
 - Automatic motor timing adjustment
 - BEC functionality to power electronics (in some ESCs)
- Modern ESCs support BLHeli or SimonK firmware for smooth and responsive control.

BLDC motors are preferred due to:

- High efficiency
- Low maintenance
- High torque-to-weight ratio
- Smooth operation

Motor selection depends on:

- KV rating: Indicates RPM per volt.
- Low KV motors → higher torque, larger propellers (used in heavy-lift drones).
- High KV motors → higher RPM, smaller propellers (used in racing drones).

Motor durability also depends on bearing quality, stator design, and cooling efficiency.

b. Propellers

Propellers convert motor rotation into thrust. For stable quadcopter operation:

- Two propellers rotate clockwise (CW)
- Two rotate counterclockwise (CCW)

This counter-rotation cancels unwanted yaw torque.

3 Power System

The power system provides the electrical energy required for propulsion and electronics.

a. Battery



Lithium Polymer (LiPo) batteries are standard due to high discharge rates and light weight.

Key parameters:

- Voltage (Cell Count):
3S → 11.1 V
Higher voltage → More power and speed
 - Capacity (mAh): Determines flight duration.
 - C-rating: Indicates maximum discharge capability.
- Selecting the right battery involves balancing flight time, weight, and power demand.

b. Power Distribution Board (PDB)



The PDB connects the battery to ESCs and other electronics. It ensures:

- Stable power flow
- Noise filtering
- Short-circuit protection

Modern flight controllers integrate PDB functionality for compact design.

c. Battery Connectors

Connectors join the battery to the main power system.

Common types:

- XT60: High current capacity, widely used.
- Deans (T-plug): Used in small to medium drones.
- XT90: Used for heavy-lift drones.

Reliable connectors reduce resistance and prevent power loss.

4 Flight Control System



The flight control system is the brain of the quadcopter. It interprets sensor data, stabilizes the aircraft, and executes commands.

a. Flight Controller (FC)

Popular flight controllers include:

- Pixhawk – advanced autonomous navigation and GPS missions
- Betaflight – high-performance racing drones
- Ardupilot – open-source and versatile

5 Communication and Navigation System

a. Radio Transmitter & Receiver

The radio system enables manual control. Using 2.4 GHz or 5.8 GHz frequencies, the transmitter sends inputs related to throttle, pitch, roll, and yaw.



Advanced radios (e.g., FrSky, FlySky, Radiomaster) feature:

- Telemetry feedback
- Adjustable control modes
- Long-range capability

b. GPS Module



GPS enhances autonomous functionality with features such as:

- Position hold
- Return-to-home (RTH)
- Autonomous mission planning (waypoints)
- Speed and altitude tracking

Modern modules such as u-Blox Neo-M8N offer fast satellite lock and high accuracy.

6 Additional Components



c. LED Lights

- Orientation visibility
- Night flying support
- Visual aesthetics
- Status indication (GPS lock, battery alert, etc.)

Key Calculations in Quadcopter Design

Designing a quadcopter requires careful calculations to ensure stability, efficiency, and performance. Below are the key calculations involved in quadcopter design:

1. Thrust-to-Weight Ratio Calculation

To achieve stable flight, the total thrust generated by the motors must be greater than the total weight of the quadcopter.

$T_{total} = W \times \text{Thrust-to-Weight Ratio}$ where:

T_{total} = Total thrust required (N or g)

W = Total weight of the quadcopter (N or g)

Thrust-to-weight ratio (Typically 2:1 for hover, 3:1 for agile performance)

The quadcopter weighs 1.5 kg (1500g) and we aim for a 2:1 thrust-to-weight ratio: $T_{total} = 1500 \times 2 = 3000$ g

Each of the 4 motors should generate:

$T \text{ per motor} = T_{total} / 4 = 3000 / 4 = 750$ g

Thus, motors must provide at least 750g of thrust each.

2. Motor Selection & Power Calculation

The power required for a motor can be estimated using: $P = T \times V$ where:

P = Power (W)

T = Thrust per motor (N)

V = Air velocity through the propeller (m/s) Additionally, motor power can be estimated as:

$P = (T \times V) / \eta$

where η is motor efficiency (typically 70-90%).

3. Propeller Selection

Propeller thrust depends on its size, pitch, and RPM. Larger propellers generate more thrust but require more power.

Larger propellers = More thrust, lower RPM, higher efficiency

Smaller propellers = Less thrust, higher RPM, more agility

Use manufacturer-provided thrust charts to match motors and propellers.

4. Battery Capacity & Flight Time Calculation

The required battery capacity is calculated using: $C_{battery} = I_{total} \times t$ where:

$C_{battery}$ = Battery capacity (mAh)

I_{total} = Total current drawn by all motors (A) t = Desired flight time (hours)

Example: If each motor draws 10A, the total current:

$total = 4 \times 10 = 40$ A

For 15 minutes (0.25 hours) of flight time:

$battery = 40 \times 0.25 = 10$ Ah = 10,000 mAh Thus, a 10,000 mAh LiPo battery is needed.

3.2.5 Frame Strength & Weight Distribution

The quadcopter's frame should support all components without excessive weight. Frame weight should be $\leq 30\%$ of total weight.

Ensure even weight distribution for stable flight.

3.2.6 ESC Selection

Electronic Speed Controllers (ESCs) should handle 20-30% more current than the motor's max draw.

$I_{ESC} \geq 1.3 \times \text{motor max}$ where:

I_{ESC} = Required ESC rating (A)

motor max = Maximum motor current (A) Example: If a motor draws 15A max, then: $I_{ESC} \geq 1.3 \times 15 = 19.5$ A

Use a 20A or 25A ESC for safety

Steps in Drone Fabrication

1. Design the 3D Model

A 3D model is created using CAD software such as:

- CATIA

The design is saved in formats like:

- STL

CAD Model Example

2. Convert to STL File

The CAD model is converted into an STL file.

- STL divides the model surface into tiny triangles.
- This file is readable by slicing software.

3. Slicing Process

The STL file is imported into slicing software such as:

- Ultimaker Cura
- PrusaSlicer The slicer:
- Converts the model into layers
- Generates tool paths
- Produces G-code for the printer

Slicing and G-code

4. Printer Setup

The operator prepares:

- Printing material
- Build plate
- Nozzle temperature
- Bed temperature

Common Material

- PLA

3D Printer Setup

5. Printing Process

The printer deposits or solidifies material layer by layer.

Main Working Principle

1. Material is fed into the printer
2. Nozzle/heater melts material
3. Material is deposited layer by layer
4. Layers fuse together to form the object

FDM Printing Process

Major Type in of 3D Printing Processes Process Material Principle FDM Thermoplastic filament Melt extrusion

Selecting the Type of Drone Configuration

Based on the application, different configurations are chosen:

1. Quadcopter (X or + configuration)

- Most common and cost-effective.

- Stable, easy to control, suitable for beginners.
- Used for photography, hobby flying, and research.

2. Hexacopter

- Six motors provide greater lift and redundancy.
- Suitable for professional cinematography and heavy payloads.

3. Octocopter

- Designed for industrial and high-risk applications.
- Can carry heavy sensors or large payloads.

Choosing the configuration affects the total cost, weight, frame size, motor choices, and control software.

Selecting the Frame Size

The frame size (measured motor-to-motor in mm—e.g., 250mm, 450mm, 550mm) depends on:

- Motor size
- Propeller diameter
- Payload requirement

Frame Material Options

Material	Advantages	Disadvantages
Carbon Fiber	Very strong, lightweight, vibration-resistant	Expensive
Aluminum	Durable, affordable	Heavier
Plastic/ABS	Cheap, easy to mold	Less durable, flexible
3D Printed (PLA/ABS/PETG)	Customizable	Requires proper reinforcement

Frame design must ensure:

- Balanced center of gravity
- Sufficient space for components
- Protection for wiring and electronics
- Aerodynamic flow

Motor and Propeller Selection

Motor selection is critical. Design is based on:

- KV rating (RPM per volt)
- Thrust-to-weight ratio
- Propeller size compatibility

Motor Selection Rules

- High KV motors (1000–2300 KV) → Small propellers, used for racing drones.

- Low KV motors (700–1000 KV) → Large propellers, used for photography or heavy-lift drones.

Propeller Considerations

- Larger propellers = more lift but slower response.
 - Smaller propellers = high speed, agile movement.
- Propellers must be correctly matched (CW and CCW), and the frame size should support the chosen diameter.

Battery Selection and Power Requirements

Drones usually use LiPo (Lithium Polymer) batteries due to high discharge rates.

Battery Choice Factors

1. Voltage (V) – More cells increase RPM (e.g., 3S=11.1V, 4S=14.8V).
2. Capacity (mAh) – Determines flight time.
3. C-Rating – Determines discharge capability.

Balancing Power and Weight

High-capacity batteries increase flight duration but also increase weight, which reduces actual flight time—this balance must be optimized using calculations or simulation tools.

Electronic Speed Controller (ESC) Planning

ESCs regulate motor speed and must match:

- Motor current rating
- Battery voltage
- Firmware type (BLHeli, SimonK, etc.) They must also be placed to ensure:
- Adequate cooling
- Minimal wiring clutter
- Correct signal routing to the flight controller

Flight Controller Selection and Software System

Flight controllers are crucial for stability and navigation.

Popular options:

- Pixhawk – Industry standard, advanced autonomy.
- Betaflight – Racing drones.
- ArduPilot / iNav – GPS-based navigation.

Features to consider:

- Gyroscope, accelerometer
- Onboard barometer, magnetometer
- GPS support
- LED and buzzer ports
- Telemetry compatibility

The choice of flight controller impacts performance, cost, and ease of tuning.

CAD Design

If creating a custom frame:

- CAD software like, CATIA, is used.
- Simulation helps prevent mechanical failure and ensures optimal geometry.

Safety Considerations in Design Phase

Safety must be incorporated from the beginning:

Electrical Safety

- Over-current protection
- Proper insulation
- Secure solder joints

Flight Safety

- GPS-based failsafe
- Geofencing
- Return-to-Home (RTH)

Cost Estimation and Budgeting

A detailed budget includes:

- Frame cost
- Motors and ESCs
- Propellers
- Flight controller
- Batteries and charger
- Communication systems
- Tools (soldering kit, wires, connectors)

Planning the budget prevents unexpected expenses later.

Documentation and Design Review

Before moving to fabrication, documentation is prepared:

- Component list
- Wiring diagram
- Frame CAD drawings
- Weight estimation
- Thrust calculations
- Power system analysis

Block diagrams

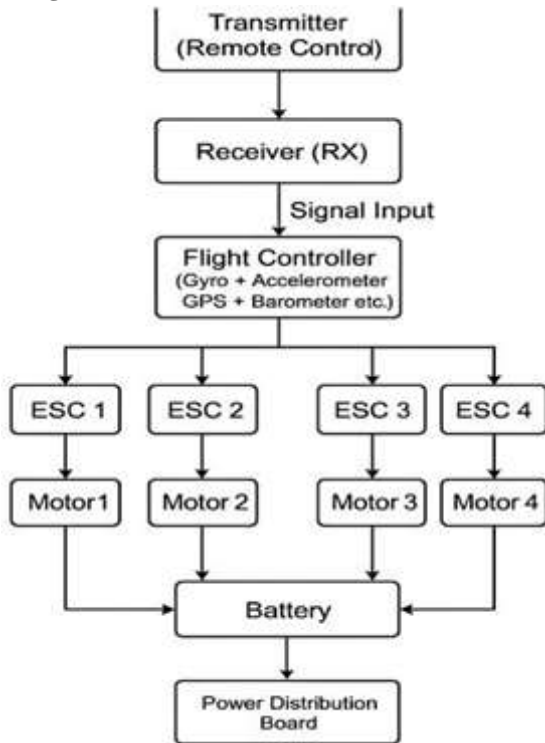

Flowchart

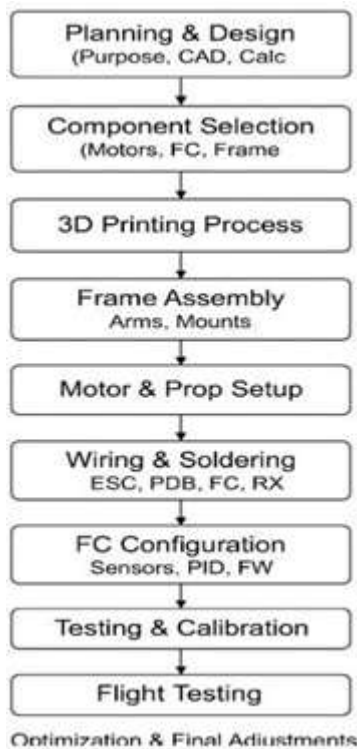

Final assembly



VIII. CONCLUSION

1. The frame is made from lightweight yet durable materials used carbon fiber
2. The motors brushless DC motors for high efficiency and longer lifespan. The 250 mm propellers for optimal thrust and stability.
3. Electronic Speed Controllers used ensure smooth and precise motor control.
4. Battery used is Lithium Polymer (LiPo) battery is giving a flight Time of 15-30 minutes depending on payload and weather conditions. The full Charging Time is 1 hours with a fast charger.
5. Flight Control & Navigation: Flight Controller: Advanced stabilization with gyroscope and accelerometer. The GPS Module enables autonomous flight, return-to-home (RTH), and waypoint navigation. Autonomous Features enables Pre-programmed flight paths and altitude hold.
6. Remote Control Range is ~1-5 km, depending on transmission power. Radio Frequency is 2.4 GHz for control, 5.8 GHz for FPV (First-Person View). FPV Camera (Optional) is HD or 4K camera with real-time video transmission.

This type of drone is ideal for hobbyists, researchers, and professionals seeking a balance between performance and affordability

Result

Following Observations are recorded after Fabrication of Drone

Trail no	Weight	Flight time	Amplitude
1	100 g	28 min	500 m

2	150	24 min	500 m
3	200	22 min	500 m
4	250	20 min	500 m
5	300	20 min	460 m

The drone performs efficiently up to 250 g payload with acceptable flight time and stable range.

Beyond 250 g, performance starts degrading noticeably.

The optimum payload range for this drone is approximately 150–250 g for balanced endurance and stability.

Discussion

The project successfully demonstrates the use of additive manufacturing technology in the design and fabrication of an Unmanned Aerial Vehicle (UAV). The use of 3D printing helped in producing lightweight and customized components with reduced material wastage and lower fabrication time. The fabricated UAV showed satisfactory flight stability, payload handling capability, and structural strength during testing. The integration of electronic components such as BLDC motors, ESCs, and flight controller enabled smooth operation and control of the UAV. Overall, the project highlights the potential of additive manufacturing in aerospace applications and proves that 3D-printed UAVs can be an economical and efficient alternative to conventionally manufactured drones.

REFERENCES

1. Anderson, J. D. (2010). *Fundamentals of Aerodynamics*. McGraw-Hill.
2. Beard, R. W., & McLain, T. W. (2012). *Small Unmanned Aircraft: Theory and Practice*. Princeton University Press.
3. Brandt, J. B., & Gilliam, T. M. (2013). "Performance Characteristics of Electric Propulsion for UAVs." *Journal of Aircraft*, 50(3), 769-778.
4. Forster, C., Carlone, L., Dellaert, F., & Scaramuzza, D. (2017). "On-Manifold Preintegration for Real-Time Visual-Inertial Odometry." *IEEE Transactions on Robotics*, 33(1), 1-21.
5. Giusti, A., Guzzi, J., Ciresan, D. C., et al. (2016). "A Machine Learning Approach to Visual Perception of Forest Trails for Mobile Robots." *IEEE Robotics and Automation Letters*, 1(2), 661-667.

6. Kim, J., Kim, Y., & Kim, H. (2018). "Design and Development of Ducted Fan UAVs for Improved Thrust Efficiency." *AIAA Journal*, 56(4), 1038-1052.
7. Lapeña-Rey, N., Walker, S., & Smith, D. (2020). "Hybrid Fuel Cell Systems for UAV Applications." *Journal of Energy Systems*, 35(2), 312-329.
8. Mohd Jani, J., Leary, M., & Subic, A. (2019). "The Role of 3D Printing in UAV Design Optimization." *Additive Manufacturing Journal*, 28, 100-112.
9. Mueller, T. J., DeLaurier, J. D., & O'Mara, M. (2017). "Airfoil Optimization for Small UAVs." *AIAA Journal*, 55(6), 1345-1362.
10. Shyy, W., Berg, M., & Ljungqvist, D. (2016). "Biomimetic Approaches to UAV Wing Design." *Progress in Aerospace Sciences*, 46(4), 284-327.
11. Tsai, S. W., & Hahn, H. T. (2013). *Introduction to Composite Materials*. Technomic Publishing.