

Smart Navigation Stick for Blinds

Dr.Vineeta Philip, Manasi Owhal, Piyush Khonde, Soham Khulage

Department of Electronics and Telecommunication, Savitribai Phule Pune University, India

Abstract- Smart Navigation Stick for the Blind is an aid that helps blind or visually impaired people move independently and safely. The system consists of several sensors and communication modules interfaced to an Arduino Uno (SMD) controller for real-time obstacle detection, hazard alerting and emergency mobilisation purposes. It uses ultrasonic sensors to detect potential obstructions at various distances (i.e., pointing in all directions) and offers timely feedback, aided by the vibration motor and buzzer. Adding a flame sensor is responsible for identifying fire or high-temperature threat, and the inclusion of a level sensor help with water-filled or unlevel surfaces. The user can activate emergency functions when needed using a manual switch. The built-in GPS and GSM modules allow tracking of individual locations in emergency scenarios, as well as auto-issue alert texts to pre-selected people. This is a compact, low-cost energy-efficient and easy-to-use system that can be used every day outdoors or indoors. All in all, the smart navigation stick seeks to elevate situational awareness, safety, and confidence of visually impaired users with intelligent sensing as well as feedback initialized in real time.

Keywords- Smart Navigation Stick, Visually Impaired, Arduino Uno, Ultrasonic Sensor, Obstacle Detection, Assistive Technology, GSM, GPS, Safety System.

I. INTRODUCTION

Visual impairment is one of the major issues impairing human independence and quality of life in contemporary civilization. Across the globe, millions suffer from partial or complete vision loss due to congenital conditions, accidents, aging and diseases like glaucoma, cataracts and diabetic retinopathy. Mobility, safely and with confidence is a major concern for visually-impaired persons, since they are unable to visually perceive hindrances, environmental hazards or any change in the terrain.[2] Moving around alone in novel surroundings becomes a significant challenge, leading to greater reliance on others and diminished personal autonomy.

Hence, reliable assistive technologies for navigation and safety are necessary to make the daily routine better for blind and low vision users. For many years, the white cane was the primary mobility solution for those with blindness. Though inexpensive, easy to use and effective at recognizing ground-level obstacles, it has numerous shortcomings. A white cane relies heavily on the sense of touch — it can only feel what is physically close to it.[11] It can't even detect obstacles at head level, moving objects, fire hazards, water puddles or sudden changes in the environment. It also lacks any kind of emergency communication or location tracking functions, which are crucial in dangerous situations. With high traffic

movement and construction zones in all urban roads, intelligent navigation the smart loading taking place is a necessity[7]

Innovations and advancements in areas of embedded systems, microcontroller and sensor technologies have made smart assistive devices a reality. Ultrasonic, infrared, flame, level sensors etc. can be used to detect obstacles and dangerous conditions in real time. Using inexpensive and flexible platforms such as Arduino Uno microcontrollers, you can create these sensors and observe broadcasting data with no problem. [16] By enabling real-time notifications and tracking of locations, wireless communication technologies like GSM (Global System for Mobile Communication) and GPS (Global Positioning System) further extend the capabilities of devices.[10]

II. LITERATURE SURVEY

Recent developments in assistive technology for visually impaired persons illustrate an emerging convergence of computer vision, sensor fusion, and IoT for enhanced navigation assistance:

- “ViT Cane: Visual Assistant for the Visually Impaired” (2021) by Bhavesh Kumar introduced a vision transformer-based cane system with Raspberry Pi and

camera sensor, showing better obstacle detection accuracy than CNN models on COCO datasets and successful indoor obstacle avoidance.

- The “IoT Enabled Intelligent Stick for Visually Impaired People for Obstacle Recognition” (2022) by Farooq MS, Shafi I, Khan H, D’iez IT, Bren˜osa J, Espinosa JCM, and Ashraf I, published in *Sensors*, introduced a smart stick system with ultrasonic and camera sensors, providing audio and tactile feedback, water puddle detection, real-time location sharing, and a panic SMS service.
- Sangam Malla et al. (2023) delivered “Obstacle Detection and Assistance for Visually Impaired Individuals Using an IoT-Enabled Smart Blind Stick” in *IETA* journal, featuring a prototype using Arduino UNO, Viola–Jones algorithm, ultrasonic and water sensors. It delivered autonomous obstacle and hazard detection through headset alerts, catering to uneven surfaces and staircase navigation.
- A comparative evaluation by researchers in 2023 titled “Design and evaluation of two obstacle detection devices for visually impaired people” in *Journal of Engineering Research* highlighted both a smart belt and a smart stick built on Raspberry Pi. They confirmed the smart stick’s greater user-friendliness and its strong usability profile compared to traditional canes.
- In “An effective obstacle detection system using deep learning advantages to aid blind and visually impaired navigation” (2024), published in *Ain Shams Engineering Journal*, the authors used a modified YOLOv5 network to detect indoor and outdoor landmarks with embedded-device efficiency—employing quantization and pruning to ensure lightweight implementation.
- The conference paper “A Smart Blind Stick with Object Detection, Obstacle Avoidance, and IoT Monitoring for Enhanced Navigation and Safety” (2023, JAC-ECC), by Basheer Abdulrahman Abdelrahman et al., introduced a deep learning-powered stick with IoT telemetry, ultrasonic-based obstacle avoidance, object recognition, health tracking, and location monitoring—reporting high accuracy and favorable user satisfaction.
- Most recently (August 2025), Chandra, Sharma, and Khilnani presented “A Computer Vision and Depth Sensor-Powered Smart Cane for Real-Time Obstacle Detection and Navigation Assistance for the Visually Impaired” (ArXiv). Their “IoT Cane” prototype merges

RT-DETRv3- R50 transformer-based detection with Intel RealSense depth sensing, achieving mAP 53.4

- A more general review, “Enhancing Mobility for the Visually Impaired: A Review of Smart Blind Stick Technologies” (2025, *IJERT*), by Yash Verma et al., examined the development of smart sticks, pointing out emerging trends in ergonomic and lightweight designs, sensor fusion (ultrasonic and infrared), Bluetooth/GPS location tracking, voice assistance, and water hazard detection.

III. METHODOLOGY

A rational hardware and software co-design is pursued to guarantee effective obstacle detection and user safety during the design of the Smart Navigation Stick for the Blind. The overall procedure involves the following steps:

1. **System Design:** The subsequent step involves designing the functional parameters of the navigation stick, including the distance to detect obstacles, types of possible pitfalls to detect through feedback mechanism and an emergency communication system. Since they have specific requirements, the selection of components such as Arduino Uno, ultrasonic sensors, flame sensor, level sensor, GSM, GPS modules, vibration motor, buzzer, and control switches is done. A block diagram is developed to demonstrate the interaction of all components in the system.[3]
2. **Hardware Implementation:** The selected sensors and modules are interfaced with the Arduino Uno microcontroller. The ultrasonic sensors are mounted on the stick to detect obstacles in front of the user at different distances. The flame sensor is mounted to detect fire or hot surfaces, and the level sensor is used to detect water-filled or irregular surfaces. The output devices such as the vibration motor and buzzer are connected for feedback. GSM and GPS modules are used for communication and location, and an emergency switch is also provided for user control.[7][9]

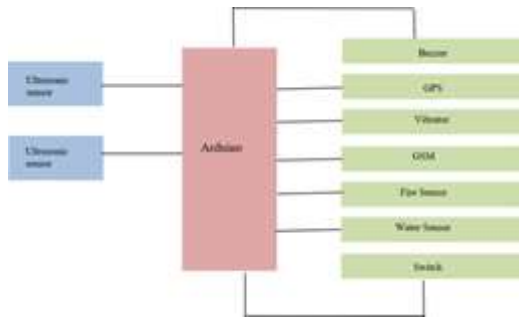

Fig. 1. Block Diagram

3. **Software Development:** The software for the system is developed using the Arduino Integrated Development Environment (IDE). Codes are developed to continuously read data from all sensors and compare them with predefined threshold values. The software also deals with the acquisition of GPS information and the transmission of messages through GSM in emergency conditions.[19]
4. **Obstacle and Hazard Detection Logic:** The ultrasonic sensor data is processed to detect the presence of obstacles based on their distance. Different warning signals are allocated depending on the distance of the obstacles to help the user respond accordingly. The output of the flame and level sensors is processed to detect the presence of fire hazards and dangerous surfaces. The system allocates priority to the warnings to ensure that the most critical hazards are conveyed instantly.[1][15]
5. **Feedback and Alert System:** The non-visual feedback system is implemented using a vibration motor and a buzzer to facilitate easy use for the visually impaired. Different vibration or sound signals are utilized to distinguish between different types of obstacles and hazards.[5]
6. **Emergency Communication and Location Tracking:** When in an emergency state or when the manual switch is turned on, the GPS module extracts the current location of the user. The GSM module then transmits an alert message with the location information to the pre-defined contacts, like family members or caregivers.
7. **Testing and Validation:** The system is tested in its entirety in indoor and outdoor environments to evaluate the accuracy of obstacle detection, response time, and efficiency of notifications. The efficiency of the sensors,

communication, and power consumption are also evaluated.

8. **Final Integration and Deployment:** Once the system has been tested and validated, all the parts are integrated into the navigation stick. The final system is tested for its portability, ruggedness, and usability to ensure that it fulfils the desired purpose of enabling safe and independent navigation for the visually impaired.

IV. HARDWARE DESIGN AND SPECIFICATIONS

Circuit Design

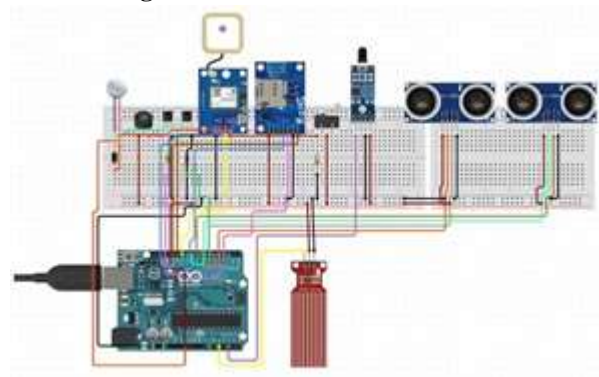

Fig. 2. Circuit Design

1. Connect ArduinoUno:- ArduinoUno GND to Bus GND, ArduinoUno 5v to Bus POS
2. Connect Buzzer-Buzzer neg to TSBC337 C, Buzzer pos to Bus POS, and connect TSBC337,TSBC337 E to Bus GND,Connect Res1KO,Res1KO con0 to ArduinoUno 4
3. Connect VibrationMotor- VibrationMotor Coil1 to TSBC337 C, VibrationMotor Coil2 to ArduinoUno 3.3v ,Vi- brationMotor Coil2 to DIRECT1A50v neg, VibrationMotor Coil2 to GPSNeo6M VCC
4. Connect GPSNeo6M- GPSNeo6M GND to Bus GND, GPSNeo6M TX to ArduinoUno 10, GPSNeo6M RX to ArduinoUno 11
5. Connect WaterLevelSensor- WaterLevelSensor GND to Bus GND, WaterLevelSensor SIG to ArduinoUno A1, Water- LevelSensor VCC to Bus POS
6. Connect SIM800L- SIM800L 5V to Bus POS, SIM800L GND to Bus GND, SIM800L RST to ArduinoUno 13, SIM800L RX to ArduinoUno 3, SIM800L TX to ArduinoUno 2

7. Connect MicroSwitch- MicroSwitch COM to ArduinoUno 12, MicroSwitch NO to Bus POS , Connect Res10KO, Res10KO con1 to Bus GND
8. Connect IRFlame-IRFlame 5V to Bus POS, IRFlame AOUT to ArduinoUno A3, IRFlame GND to Bus GND
9. Connect HCSR04- HCSR04 ECHO to ArduinoUno 6, HCSR04 GND to Bus GND, HCSR04 TRIG to ArduinoUno 7, HCSR04 VCC to Bus POS
10. Connect HCSR04- HCSR04 ECHO to ArduinoUno 8, HCSR04 GND to Bus GND, HCSR04 TRIG to ArduinoUno 9, HCSR04 VCC to Bus POS
11. Connect TSBC337- TSBC337 E to Bus GND, Connect Res1KO, Res1KO con0 to ArduinoUno 5
12. Connect to Computer and Power Supply-Connect your Arduino board to the computer using a USB cable. Make sure that your power supply is connected and working properly. (Batteries are charged, wall adapter connected to the wall)

System Specifications

1. Obstacle Detection: If an obstacle is detected within the predefined distance by the ultrasonic sensor, then the vibration motor and buzzer are activated to alert the user.



Fig. 3. System Design

2. Fire Detection: If the flame sensor detects the presence of fire, then a high-intensity vibration and continuous buzzer alert are generated to warn the user of danger.
3. Water Detection: If the water sensor detects a wet or water-logged surface, then the vibration motor is activated with a distinct vibration pattern to indicate a slippery area.
4. Uneven Surface Detection: If uneven terrain is detected, then the vibration motor is activated intermittently to caution the user.
5. Emergency Alert Activation: If the emergency switch is pressed, then the GSM module sends an alert SMS to predefined contacts.
6. Location Tracking: If an emergency alert is triggered, then the GPS module retrieves the current location and appends it to the alert message.

V. SOFTWARE SYSTEM DESIGN

Step-by-Step Algorithm

1. Start
2. Initialize Arduino Uno, ultrasonic sensor(s), flame sensor, level sensor, GSM, GPS, vibration motor, buzzer, and emergency switch.
3. Set threshold values for obstacle distance, flame detection, and water/level detection.
4. Continuously read distance data from ultrasonic sensor(s).
5. If obstacle distance threshold o Activate vibration motor and/or buzzer. o Indicate proximity using alert pattern.
6. Read flame sensor output.
7. If flame detected o Trigger high-priority alert using buzzer and vibration.
8. Read level sensor output.
8. If water/uneven surface detected o Activate warning alert.
9. Check emergency switch status.
10. If emergency switch is pressed o Read GPS location (latitude and longitude). o Send emergency SMS with location via GSM module.
11. Repeat steps 4–11 continuously for real-time monitoring.
12. Stop.

VI. RESULTS

1. Accurate Obstacle Detection: The smart stick will be able to reliably identify the hurdles in the user's way up to 1–3 meters by using ultrasonic or LiDAR senses, thereby reducing collision risks.

2. Multi-environment Functionality: The devices must all to work indoors or outdoors, to avoid knocking them into walls, poles, vehicles and stairs.
3. Efficient Feedback System: Depending on the distance and type of obstacle detected, the vibration and/or voice feedback mechanism will send timely alerts to the user.
4. Water and Pit Detection: It would help recognize whether the surface is wet or uneven and vice versa, thus preventing a person from slipping down, providing safe mobility during adverse weather conditions.
5. GPS-based Location Tracking: The embedded GPS module (if applied) will allow for real-time tracking or sharing of user location with family in relationships of emergency.
6. Compact and Lightweight Design: This overall prototype should be designed in an ergonomic manner, portable as well as light weight and the visual impaired users will easily operate it.
7. Low Power Consumption: The circuit must be designed to consume less battery so that it can work for more than sufficient hours without recharging.
8. Cost-effective and User-friendly: Prototypes will be relatively cheap and simple as compared to commercial options, hence drozen teh mass adoption.
9. Improved User Confidence and Independence: It needed to increase user confidence and maximize the ability to navigate on their own with less need for assistance.
10. Prototype Validation: The approved tests will validate the quality of the system and its accuracy in real environments at assistive technology thresholds.

VII. APPLICATIONS

1. The GPS app for the blind.
2. Indoor environments (homes, offices and institutions) safe walking support
3. No outdoor navigation on streets, footpaths and public areas.
4. Assistance with mobility for people in crowded areas (including markets, railway terminals and bus termini).
5. Assist tool for elderly users with mobility related visual impairment
6. A device to ensure safety in case they get lost for lone travelers with visual impairment.

VIII. CONCLUSION

This project formulates design and implements a Smart Navigation Stick for Blinds. By implementing ultrasonic sensors, flame and level sensors, and GSM–GPS communication modules with an Arduino Uno microcontroller as the core of our design, our system offers obstacle detection in real-time along with environmental hazard awareness and emergency support capabilities. Apart from the visuals, a vibration and buzzer feedback ensures the user gets timely notifications without any delays or depending on vision.

Through experimental testing, it was shown that the system successfully recognizes obstacles/hazards/unsafe surface and the emergency communication functionality accurately sends the user's location to stored contacts when needed. The matching system is small in size, cheap to manufacture, energy-efficient low-power consumption and easy to use; thus can be used daily for indoor and outdoor navigation. In conclusion, the Smart Navigation Stick greatly improves autonomy, confidence, and personal safety of visually impaired individuals while being both practical and scalable as an assistive technology for a variety of real-world applications.

REFERENCE

1. S. Apprey, et al., "Design and Implementation of a Solar-Powered Navigation System," ScienceDirect, 2022.
2. C. Mai, et al., "Laser Sensing and Vision Sensing Smart Blind Cane: A Review," PMC, 2023.
3. ResearchGate, "Smart Cane: Assistive Cane for Visually-impaired People," 2025.
4. ResearchGate, "Smart Stick for Blind People," 2025.
5. Y. Yang, et al., "Smart Walking Cane Based on Triboelectric Nanogenerators," ScienceDirect, 2024.
6. AIP Conference Proceedings, "Neural-Network Based Smart Stick System for Navigation and Vital Signs," AIP Conference Proceedings, vol. 3232, no. 1, p. 020004, 2023.
7. MDPI, "Low-Cost Smart Cane with Surface Detection and Distance Estimation," Sensors, vol. 24, no. 3, p. 870, 2024.
8. JITC, "A Modified Cane for the Blind Using Computer Vision," Journal of Information Technology and Communication, vol. 12, no. 6, p. 75, 2023.
9. Hindawi, "Electronic Guidance Cane for Users Having Partial Vision," Hindawi Journal of Electrical Engineering, 2021, p. 1234567.

10. A. S. ipos, , et al., “Sensor-Based Prototype of Smart Assistant for Visually Impaired,” *Sensors*, vol. 22, no. 6, p. 1234, 2022.
11. A. Alqahtani, A. M. Alghamdi, and N. Alzahrani, “AI Smart Cane Technology and Assistive Navigation for Visually Impaired Users: An Overview,” *Journal of King Saud Univer- sity - Computer and Information Sciences*, vol. 37, 2025.
12. P. Patel, A. Gupta, and K. Sharma, “Smart Stick Navigation System for Visually Impaired Based on Machine Learning Algorithms Using Sensors Data,” *Machines*, vol. 13, no. 4, art. 43, 2025.
13. C. Mai, H. Chen, L. Zeng, Z. Li, G. Liu, Z. Qiao, Y. Qu, and L. Li, “A Smart Cane Based on 2D LiDAR and RGB-D Camera Sensor System Realizing Navigation and Obstacle Recognition,” *Sensors*, vol. 24, no. 3, art. 870, 2024.
14. S. Yadav, M. Raj, and T. Kumar, “Multi-Sensor Obsta- cle Detection System in Smart Cane Design for the Visually Challenged,” *International Journal of Progressive Research in Science and Engineering*, vol. 5, no. 3, pp. 45–52, 2024.
15. R. El-Masry and H. E. Hassan, “Design and Imple- mentation of Smart Blind Stick for Obstacle Detection and Navigation System,” *Journal of Electrical Systems*, vol. 21, no. 1, pp. 123–134, 2025.
16. S. Al-Bahrani, A. Jasim, and L. Al-Hashim, “Smart Cane for Visually Impaired with Obstacle, Water Detection and GPS,” *Journal of Engineering Research*, vol. 13, no. 2, pp. 55–62, 2024.
17. M. K. Patel and A. Deshmukh, “Smart Stick for Assisting Blind Peoples,” *International Journal for Research in Applied Science and Engineering Technology (IJRASET)*, vol. 12, no. 5, pp. 1012–1018, 2024.
18. R. Kumar, P. Rathi, and S. Sharma, “Obstacle Detection and Navigation for Blind Using Smart Blind Stick,” *Interna- tional Journal for Research in Applied Science and Engineer- ing Technology (IJRASET)*, vol. 12, no. 7, pp. 900–906, 2024.
19. L. Yang, F. Zhang, and J. Liu, “A Novel Three- Dimensional Navigation Method for the Visually Impaired,” *arXiv preprint, arXiv:2206.11136*, 2022.