

IoT Based Driving License Detection and Safety System

H. M. Pawar¹, Deore Shrawani Shashikant², Kapadnis Tejas Sudhakar³, Pagar Shubham Manik⁴

¹Assistant Professor, Department Of Electrical Engineering, Sanghavi Collage Of Engineering, Varvandi, Mhasrul, Maharashtra, India

^{2,3,4}Ug Student, Department Of Electrical Engineering, Sanghavi Collage Of Engineering, Varvandi, Mhasrul, Maharashtra, India.

Abstract- With the rapid increase in road accidents and traffic violations, ensuring driver authenticity and safety has become a major concern. This paper presents an IoT-Based Driving License Detection and Safety System designed to verify the validity of a driver's license and enhance road safety through real-time monitoring. The proposed system integrates RFID/QR code-based license identification with IoT-enabled devices to authenticate drivers before vehicle ignition. A microcontroller-based unit processes the data and checks it against a stored or cloud-based database. If the license is invalid, expired, or not detected, the system restricts vehicle operation and sends alerts to concerned authorities or vehicle owners. Additionally, safety features such as alcohol detection, seat belt monitoring, and accident detection are incorporated to minimize risks. The system uses wireless communication technologies to transmit real-time data and alerts. This approach not only prevents unauthorized vehicle usage but also promotes responsible driving behavior. Experimental results demonstrate that the system is efficient, reliable, and suitable for smart transportation and intelligent traffic management systems.

Keywords – IoT, Driving License Detection, RFID, QR Code, Vehicle Safety System, Alcohol Detection, Accident Detection, Smart Transportation, Embedded System, Real-Time Monitoring.

I. INTRODUCTION

In this project to develop the system driving license detection and safety system. The system is done by interfacing Node MCU Board with number of sensor.

In this project we are using Node MCU Microcontroller. When the RFID tag is swapped the motor will on and off. The alcohol sensor, to detect the drink and drive and voice module to produce a deep sound If the person is drunken so send the message to person and to change the driver. It is a voice interactive system.

RFID reader to read the tags. The Alcohol level and license name and number will be displayed on the LCD, web application and Android application.

The Node MCU interface with Microcontroller. Through Wi-Fi, the reading will be taken on the android app and web application. Alcohol level, License name, notification through mobile application and display on LCD.

This system is implemented Alcohol sensor, RFID Reader, RFID Tag, Relay module, motor, Voice module, Node MCU as it has inbuilt Wi-Fi module all the data is transferred to the cloud through Wi-Fi and analysis is done in mobile application and web applications.

Need Of Project Objective

- The need for an IoT-based driving license detection project is to improve road safety, reduce fraud, and create a more efficient and transparent licensing process through real-time data collection and monitoring.
- This system aims to automate driving tests, detect violations, and integrate data from a driver's license into vehicle security and monitoring to ensure the right person is driving and to track vehicle usage, as outlined in sources

Objectives

- To display Alcohol sensor level, License name and number on LCD and Android app & Web development To detect the driving license for accident safety.
- Ensure Only Authorized Drivers Operate Vehicles
- Prevent Fraud and the Use of Fake Licenses
- Improve Traffic Management System Efficiency

II. LITERATURE SURVEY

An IoT-based driving license detection literature survey includes papers on real-time license verification using technologies like RFID and biometrics, integrated with IoT platforms for data logging and remote access

These systems connect a driver's license to a central database for instant validation via a gateway like NodeMCU or Arduino, often combined with sensors for added security like alcohol detection. Research also covers automated driving tests using IoT sensors to evaluate driver performance and evaluate the feasibility of such systems in real-world scenarios.

Binu P K, Sredhey K J “An IoT Based Safety and Security Mechanism for Passenger Vehicles” In this project the driver and passengers in the vehicle to be alert enough while they are having a ride and thus providing better security features for the passenger vehicles. Increased count in road accidents now a days are mainly because of rash driving, low vigilance level of the driver, drunken driving etc. Here we are trying to come up with a prototype which helps in real time monitoring of driver and provide necessary alerts if the situation demands. There have been several works developed before on the same topic.

Bhuta, Desai, Keni “Alcohol Detection and Vehicle Controlling” The system detects the presence of alcohol in the vehicle. MQ3 gas sensor has high sensitivity to Alcohol, and has good resistance to disturb of gasoline, smoke and vapor. The sensor could be used to detect alcohol. The system implemented by us aims at reducing the road accidents in the near future due to drunken driving. The system detects the presence of alcohol in the vehicle and immediately locks the engine of the vehicle. MQ-3 gas sensor has high sensitivity to Alcohol, and has good resistance to disturb of gasoline, smoke and vapor. The sensor could be used to detect alcohol with different concentration; it is with low cost and suitable for different application.

Sayanee Nanda, Harshada Joshi, Smita Khairnar An IOT Based Smart System for Accident Prevention and Detection The system provides an idiosyncratic prevention and detection system that dispenses the ultimate panacea for drivers which ensures safety and prevents loss of life by taking appropriate measures in right time. It also checks whether the driver is drowsy or in an unstable state which can lead to pedal mix-up and in some cases unintended acceleration or turning of the steering wheel to the wrong direction which can lead to crashing of the vehicle with other vehicles or concrete road barrier. This system also provides a mechanism by which it identifies whether the person that will be riding the bike has a valid driving license or a driving license at all by already embedded RFID on driving license.

P.Manikandan, V.Muneeswaran, G.Ramesh “Drunk and drive controller for vehicles” The system sensors will sense the amount of alcohol consumed by the driver and if it crosses a particular limit then the system must send a command to stop the engine and the engine will not be turned on and thus decreasing the chance of an accident. We can reduce the number of accidents.

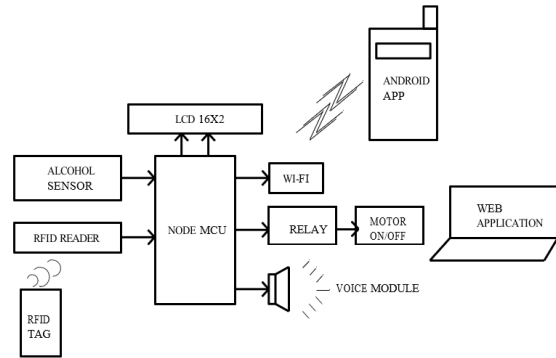

Flowchart

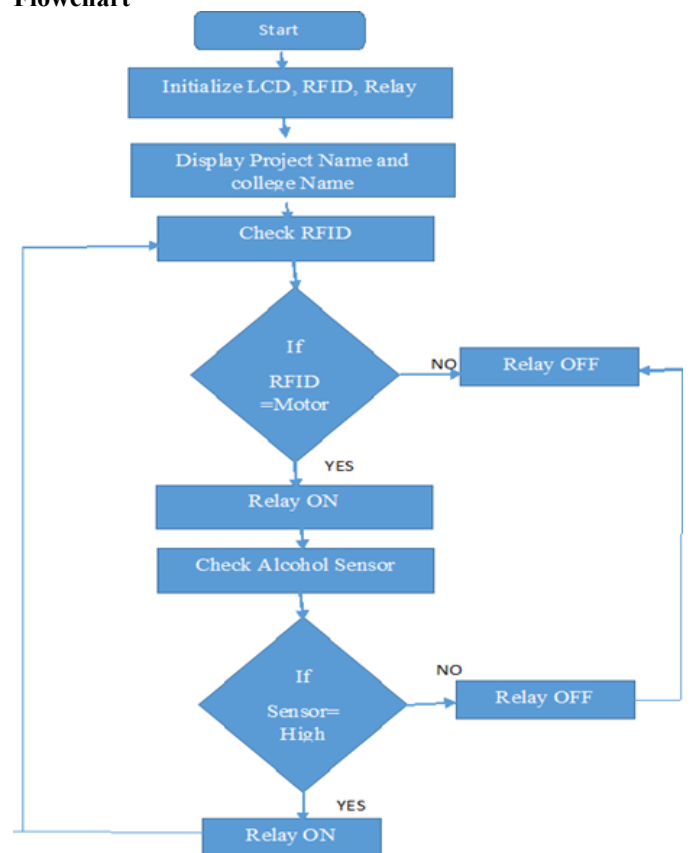

Circuit Diagram

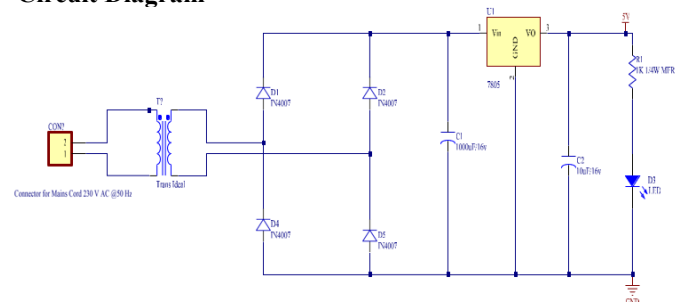

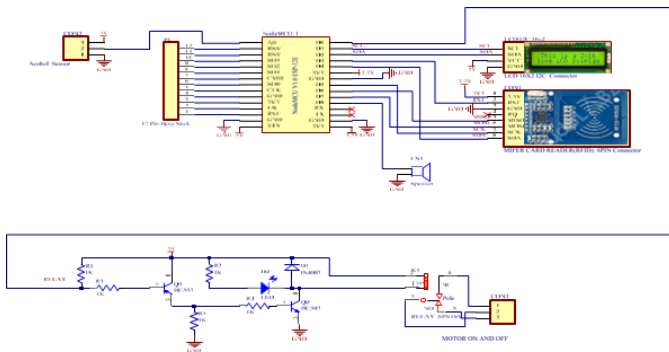

Future Scope

This paper introduces a prototype that will help a normal passenger vehicle to achieve the same security features that a high-end vehicle or premium vehicle has, thus providing better security features to normal passenger vehicles in the most cost-effective manner.

III. CONCLUSIONS

The system prevents accidents by monitoring various conditions, detection of drunken driving cases, and many more. Adding alcohol detection to the same system, this prototype can be used as an alcohol detection system. To avoid accidents using expression reading and using MQ sensors to identify any gas leakages and to identify whether the driver is alcoholic and to give real-time alarm about the situation.

REFERENCES

1. Binu P K, Sredhey K J, "An IoT Based Safety and Security Mechanism for Passenger Vehicles" International conference on intelligent computing, Instrumentation and control technology 2019.
2. Bhuta, Desai, Keni, "Alcohol Detection and Vehicle Controlling" International Journal of Engineering Trends and Applications (IJETA) Volume 2 Issue 2, Mar-Apr 2015.
3. Sayanee Nanda, Harshada Joshi, Smita Khairnar "An IOT Based Smart System for Accident Prevention and Detection" International Conference on Industrial Informatics. IEEE, 2016.
4. P.Manikandan, V.Muneeswaran, G.Ramesh Drunk and drive controller for vehicles International Conference on Industrial Informatics. IEEE, 2016.