

Smart Lithium-Ion Battery Monitoring, Protection and Automatic Switching System

H. M. Pawar¹, Kawar Arpita Chandrashekhar², Aher Vaishnavi Sanjay³, Birari Prafull Pravin⁴,
Jadhav Rushikesh Hiranman⁵

¹Assistant Professor, Department Of Electrical Engineering, Sanghavi Collage Of Engineering, Varvandi, Mhasrul, Maharashtra, India.
^{1,2,3,4,5}Ug Student, Department Of Electrical Engineering, Sanghavi Collage Of Engineering, Varvandi, Mhasrul, Maharashtra, India

Abstract- The increasing demand for reliable and efficient energy storage systems has led to the widespread use of lithium-ion batteries in various applications such as electric vehicles, renewable energy systems, and portable electronics. However, these batteries are highly sensitive to conditions like overcharging, over-discharging, overheating, and short circuits, which can reduce their lifespan and pose safety risks. This paper presents a Smart Lithium-Ion Battery Monitoring, Protection, and Automatic Switching System designed to enhance battery performance and safety. The proposed system continuously monitors key parameters such as voltage, current, and temperature using embedded sensors and a microcontroller-based control unit. It incorporates protection mechanisms to prevent hazardous conditions and ensures optimal battery operation. Additionally, an automatic switching feature is implemented to seamlessly transition between power sources or backup batteries during faults or low charge conditions. The system improves reliability, efficiency, and longevity of lithium-ion batteries while minimizing human intervention. Experimental results demonstrate the effectiveness of the proposed system in real-time monitoring and protection, making it suitable for modern energy management applications.

Keywords – Lithium-Ion Battery, Battery Management System (BMS), Smart Monitoring, Overcharge Protection, Temperature Control, Automatic Switching, Energy Management System, Embedded System, Battery Safety, Power Backup System.

I. INTRODUCTION

With the rapid growth of portable electronics, electric vehicles, and renewable energy systems, lithium-ion batteries have become the most widely used energy storage solution due to their high energy density, long life cycle, and lightweight nature. However, these batteries are highly sensitive to operating conditions such as overcharging, deep discharging, overheating, and short circuits, which can lead to performance degradation, safety hazards, or even battery failure.

To ensure safe and efficient operation, a Smart Lithium-Ion Battery Monitoring, Protection and Automatic Switching System is essential. This system continuously monitors critical battery parameters such as voltage, current, temperature, and state of charge (SOC) using sensors and microcontroller-based control units. Based on real-time data, it provides protection by disconnecting the battery during abnormal conditions like overvoltage, undervoltage, overcurrent, or excessive temperature.

In addition to protection, the system also features automatic switching, which enables seamless transition between battery sources, backup systems, or charging circuits without interrupting the load. This improves system reliability and

ensures uninterrupted power supply in applications such as UPS systems, electric vehicles, and solar energy storage systems.

Overall, this smart system enhances battery safety, lifespan, performance, and energy efficiency, making it a crucial component in modern energy management solutions.

II. NEED OF PROJECT OBJECTIVE

Lithium-ion batteries are widely used in modern applications such as electric vehicles, mobile devices, UPS systems, and renewable energy storage. Despite their advantages, they are highly sensitive to improper operating conditions. Without proper monitoring and protection, these batteries can suffer from reduced lifespan, efficiency loss, or even dangerous failures like overheating, fire, or explosion.

Traditional battery systems often lack real-time monitoring and intelligent control, making them unreliable in critical applications. Also, manual switching between power sources can cause interruptions and inefficiencies. Therefore, there is a strong need for a smart system that can:

- Continuously monitor battery parameters (voltage, current, temperature)
- Provide automatic protection against faults
- Ensure uninterrupted power supply through automatic switching
- Improve battery performance and safety

This project addresses these challenges by developing a smart lithium-ion battery monitoring, protection, and automatic switching system.

Objectives

The main objectives of this project are:

1. To monitor battery parameters

Measure voltage, current, and temperature in real-time using sensors.

2. To ensure battery protection

Protect the battery from:

- Overcharging
- Deep discharge
- Overcurrent
- Overheating

3. To implement automatic switching

Automatically switch between:

- Battery and external power supply
- Backup battery systems without interrupting the load.

4. To improve battery life and efficiency

Optimize charging and discharging cycles to extend battery lifespan.

5. To enhance system safety

Prevent hazardous conditions like short circuits and thermal runaway.

6. To develop a smart control system

Use a microcontroller (like Arduino) for intelligent decision-making and automation.

7. To provide user indication/display

Display battery status (charge level, faults, temperature) using LCD/LED indicators.

III. LITERATURE SURVEY

Recent advancements in lithium-ion battery technology have focused on improving safety, monitoring accuracy, and intelligent control systems. Various researchers have contributed to the development of Battery Management Systems (BMS) that ensure reliable operation of lithium-ion batteries in applications such as electric vehicles, renewable energy systems, and portable electronics.

A comprehensive review by researchers (2024) highlights that multi-parameter monitoring—including voltage, temperature, deformation, and gas sensing—is essential for safe battery operation. It emphasizes that intelligent sensing and data-driven algorithms play a crucial role in improving battery performance and preventing failures.

Another study on lithium-ion battery protection systems explains that a robust BMS must protect against overcharging, over-discharging, overheating, and short circuits, as failure in these conditions can lead to fire or explosion. The study also highlights the importance of cell balancing and fault detection in critical applications.

Research work published in 2023 focuses on the design of battery protection circuits, where voltage and current are continuously monitored and controlled within safe limits. These systems use electronic switching devices to disconnect the battery under abnormal conditions, ensuring safety and reliability.

A study on power management ICs (2021) presents an integrated monitoring and protection system for lithium-ion battery packs. It demonstrates how microcontroller-based or IC-based systems can provide high precision and real-time control for battery safety and efficient energy utilization.

Thermal safety is another major concern. A review on thermal runaway (2023) explains that early detection of temperature rise and thermal instability is critical to prevent catastrophic battery failure. Advanced warning and protection technologies are required for safe battery operation.

Furthermore, research on health monitoring systems indicates that fault detection and remaining useful life (RUL) prediction are essential for improving battery lifespan and reliability. These systems use data analysis and predictive models to identify degradation early and optimize maintenance.

Recent studies also explore advanced monitoring techniques such as magnetic field sensing and real-time data acquisition, which improve the accuracy of detecting internal battery conditions during charging and discharging processes.

IV. BLOCK DIAGRAM

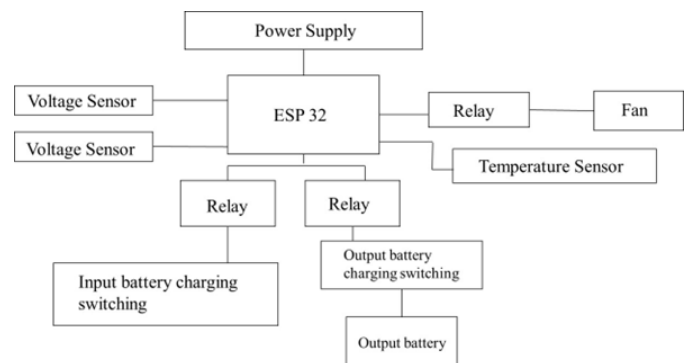

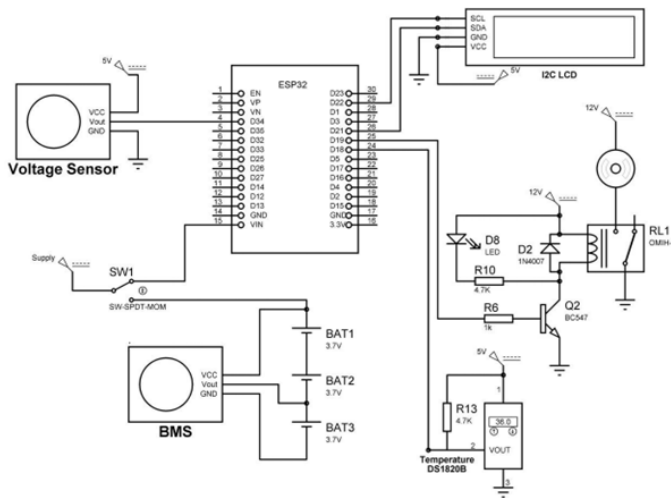

V. WORKING

1. Power Supply & Initialization

- The system is powered through a DC supply and lithium-ion battery pack (3 × 3.7V cells).
- The BMS (Battery Management System) ensures basic protection like cell balancing and safe charging.
- The ESP32 microcontroller is the main control unit that manages all operations.

2. Voltage Monitoring

- Voltage sensors are connected to:
 - Battery pack
 - Input supply
- These sensors continuously send analog voltage data to the ESP32.
- The ESP32:
 - Checks for overvoltage (overcharging condition)
 - Checks for undervoltage (deep discharge condition)
- If voltage goes beyond safe limits:
 - System disconnects battery using relay
 - Prevents battery damage

3. Temperature Monitoring

- A DS18B20 temperature sensor is used.
- It continuously measures battery temperature and sends data to ESP32.
- If temperature exceeds safe limit:
 - ESP32 turns ON cooling fan (via relay)
 - If temperature is too high → battery is disconnected

4. Relay Control Circuit

- Relay is driven using:
 - BC547 transistor
 - Diode (1N4007) for back EMF protection

- ESP32 gives signal → transistor switches → relay operates
- **Relay functions:**
 - Connect/disconnect battery
 - Switch between charging and load
 - Control cooling fan

5. Automatic Switching Operation

(A) Input Battery Charging Switching

- When external power supply is available:
 - Relay connects battery to charging circuit
 - Battery starts charging safely
- If supply is OFF:
 - System switches to battery mode automatically

(B) Output Battery Switching

- If one battery becomes weak:
 - ESP32 detects low voltage
 - Automatically switches to another battery/source
 - Ensures continuous power supply (no interruption)

Protection Features

The system provides multiple protections:

- Overcharge Protection → Cuts off charging
- Deep Discharge Protection → Disconnects load
- Overcurrent Protection → Prevents damage
- Thermal Protection → Activates fan / shuts system
- Short Circuit Protection → Relay disconnects immediately

Display System (I2C LCD)

- LCD shows real-time data:
 - Battery Voltage
 - Temperature
 - Charging Status
 - Fault Conditions

Overall System Operation Flow

- System ON → ESP32 starts monitoring
- Reads voltage & temperature continuously
- Compares values with safe limits
- Controls relays accordingly:
 - Charging ON/OFF
 - Load switching
 - Fan control
- Displays status on LCD
- Automatically switches power source when needed

VI. CONCLUSION

Based on the review, it is clear that an integrated system combining real-time monitoring, protection, and automatic switching is essential for modern applications. The proposed

project aims to develop a smart, efficient, and reliable solution that overcomes the limitations of existing systems while enhancing battery safety, performance, and lifespan.

REFERENCES

1. L. Rimon et al., "System Protection for Lithium-Ion Batteries Management System: A Review," *IJEECS*, 2019.
2. S. Yin et al., "Thermal Runaway Monitoring and Protection," *Processes*, 2023.
3. X. Tan et al., "Battery Monitoring using Magnetic Field Sensing," *IJES*, 2024.
4. J. Jiang et al., "Lithium-Ion Battery Protection Circuit," *Journal of Semiconductors*, 2014.
5. A. Habib et al., "BMS for Electric Vehicles," *Batteries*, 2023.