

AIRMATH: PARALYSIS PATIENT HEALTH CARE MONITORING SYSTEM

Tanvi Ramkumar Sunewad , Shahin Tanvir Shaikh , Divya Hemant Dhende , Diksha Datta Jethe

Electronics And Telecommunication
Jaywantrao Sawant Polytechnic
Pune, India

Abstract- Paralysis is a debilitating condition that significantly impairs a patient's ability to move and communicate, often resulting from neurological disorders, spinal cord injuries, or diseases such as stroke. According to the World Health Organization, stroke and related neurological conditions are among the leading causes of long-term disability worldwide, emphasizing the need for continuous and reliable patient monitoring systems. The Paralysis Patient Health Care Monitoring System is an advanced, technology-driven solution designed to continuously monitor the vital parameters and safety of paralyzed patients in hospitals or home environments. The system integrates biomedical sensors to track essential health indicators such as heart rate, body temperature, blood pressure, oxygen saturation (SpO₂), and movement detection. These parameters are processed through a microcontroller-based unit and transmitted via wireless communication modules to caregivers or medical professionals in real time. The proposed system also incorporates emergency alert mechanisms, enabling patients to communicate distress signals through minimal physical input, such as eye blink detection or slight finger movement sensors. In critical situations, automated notifications are sent to caregivers or healthcare providers to ensure immediate medical intervention. Data collected by the system can be stored in a cloud-based database for continuous analysis, enabling long-term health trend monitoring and improved clinical decision-making. The system enhances patient safety, reduces the burden on caregivers, and supports timely medical response, ultimately improving the quality of life for paralysis patients. In conclusion, the Paralysis Patient Health Care Monitoring System provides an efficient, reliable, and cost-effective approach to continuous health monitoring, promoting better patient outcomes through real-time data tracking, remote accessibility, and intelligent alert mechanisms.

Keywords: Paralysis, Health Care Monitoring System, IoT, Biomedical Sensors, Remote Patient Monitoring, Emergency Alert System, Wireless Communication, Cloud-Based Healthcare.

I. INTRODUCTION

Paralysis is a life-altering medical condition characterized by the loss of muscle function in part or most of the body. It may occur due to spinal cord injuries, stroke, neurological disorders, or traumatic brain injuries. According to the World Health Organization, neurological conditions and stroke are major contributors to long-term disability worldwide. Patients suffering from paralysis often require continuous medical supervision, assistance with daily activities, and timely emergency support.

Traditional caregiving methods rely heavily on manual observation, which can be time-consuming, labor-intensive, and prone to delays in emergency situations. With advancements in embedded systems, biomedical sensors, and Internet of Things (IoT) technology, automated health monitoring systems have become a practical solution for improving patient care and safety.

The Paralysis Patient Health Care Monitoring System is designed to provide continuous, realtime monitoring of vital physiological parameters such as heart rate, body temperature, blood pressure, oxygen saturation (SpO₂), and movement detection. The system integrates sensors with a microcontroller-based processing unit that collects and analyzes patient data. Using wireless communication technologies such as Wi-Fi, GSM, or Bluetooth, the data is transmitted to caregivers, hospitals, or family members for remote monitoring.

In addition to health monitoring, the system incorporates an emergency alert mechanism that enables patients with limited mobility to communicate distress signals through minimal physical actions, such as eye blink detection or slight finger movement. Alerts are instantly sent to caregivers or healthcare professionals, ensuring quick medical intervention. Furthermore, cloud-based data storage allows long-term health tracking and supports informed medical decision-making. By combining sensor technology, IoT connectivity, and intelligent alert systems, the proposed monitoring system

enhances patient safety, reduces caregiver burden, and improves overall quality of life for paralysis patients.

II. SYSTEM OVERVIEW

The Paralysis Patient Health Care Monitoring System is an advanced IoT-based healthcare solution designed to provide continuous monitoring and assistance to patients suffering from partial or complete paralysis. Paralysis often occurs due to stroke, spinal cord injury, or neurological disorders, and according to the World Health Organization, such conditions are among the leading causes of long-term disability worldwide. This system integrates biomedical sensors to measure vital parameters such as heart rate, body temperature, blood pressure, oxygen saturation (SpO₂), and body movement. The collected data is processed using a microcontroller-based unit, which analyzes the readings and detects any abnormalities. Through wireless communication technologies such as Wi-Fi or GSM, the patient's health data is transmitted in real time to caregivers or healthcare professionals for remote monitoring. The system also incorporates an emergency alert mechanism that enables patients to send distress signals using minimal physical movement, ensuring immediate medical attention when required. Additionally, cloud-based storage allows long-term data tracking and analysis to support informed clinical decisions. Overall, the system enhances patient safety, reduces caregiver burden, and improves the quality of healthcare delivery for paralysis patients.

III. METHODOLOGY

The methodology of the Paralysis Patient Health Care Monitoring System is designed to ensure continuous health supervision, real-time data transmission, and rapid emergency response for paralysis patients. The system follows a structured approach that includes data acquisition, processing, transmission, alert generation, and data storage.

Initially, biomedical sensors are attached to the patient's body to collect vital physiological parameters such as heart rate, body temperature, blood pressure, oxygen saturation (SpO₂), and movement activity. These sensors continuously monitor the patient's condition and send the acquired signals to a microcontroller-based processing unit (such as Arduino, NodeMCU, or Raspberry Pi). The microcontroller converts analog signals into digital data and analyzes them based on predefined threshold values.

In the next stage, the processed data is transmitted using wireless communication technologies such as Wi-Fi, GSM, or Bluetooth to a remote monitoring platform. Caregivers and healthcare professionals can access the patient's health status

through a mobile application or web-based dashboard. If any parameter exceeds or falls below the normal range, the system automatically triggers an alert notification via SMS, alarm, or app notification.

Additionally, the system incorporates an emergency communication mechanism that enables paralysis patients to send distress signals using minimal physical movement, such as eye blink detection or slight finger motion. When activated, immediate alerts are sent to caregivers or medical staff to ensure prompt assistance.

All collected data is stored in a cloud-based database for long-term monitoring, trend analysis, and medical evaluation. This structured methodology ensures reliable health tracking, reduces manual supervision, and enhances patient safety through intelligent monitoring and automated response mechanisms.

IV. CIRCUIT DIAGRAM

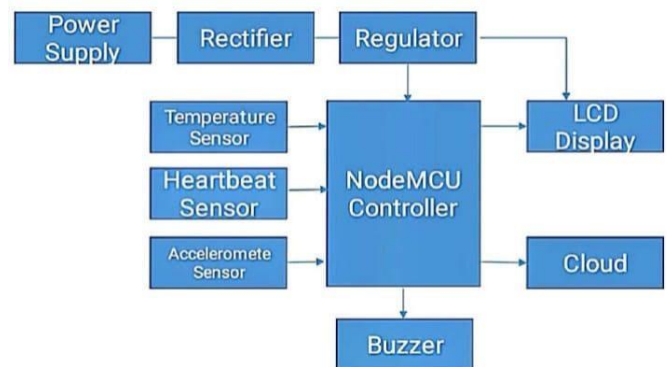

Sensor Block (Input Unit)

This is the first block of the system. It consists of biomedical sensors used to measure vital health parameters such as heart rate, body temperature, blood pressure, oxygen saturation (SpO₂), and movement detection. These sensors are attached to the patient's body and continuously collect physiological data. The signals generated by the sensors may be analog or digital in nature.

Signal Conditioning Block

The signals obtained from sensors are sometimes weak or noisy. Therefore, a signal conditioning unit (including amplifiers and filters) is used to enhance, filter, and stabilize the signals before sending them to the processing unit. This ensures accurate and reliable readings.

Microcontroller/Processing Block

This is the central control unit of the system. A microcontroller (such as Arduino, NodeMCU, or Raspberry Pi) receives input from the sensors, converts analog signals into digital form (if required), and processes the data. The programmed controller compares the measured values with predefined normal threshold values. If any abnormality is detected, it initiates necessary actions such as generating alerts.

Communication Block

The communication module enables wireless data transmission. Technologies such as Wi-Fi, GSM, or Bluetooth are used to send patient data to caregivers, hospitals, or family members. This block ensures remote monitoring through mobile applications or web dashboards.

Display Block

An LCD or LED display unit is used to show real-time health parameters locally. This helps caregivers present near the patient to quickly observe current readings without accessing a remote system.

Emergency Alert Block

This block activates when abnormal health conditions are detected or when the patient triggers a distress signal (for example, through eye blink detection or slight finger movement). It sends instant notifications via SMS, buzzer alarm, or mobile app alerts to caregivers and medical professionals.

Cloud Storage Block

All monitored data is stored in a cloud database for long-term record maintenance, analysis, and medical evaluation. This allows doctors to track patient health history and make informed decisions.

Power Supply Block

The power supply unit provides required electrical power to all components of the system. It may include batteries or regulated DC power sources to ensure uninterrupted operation.

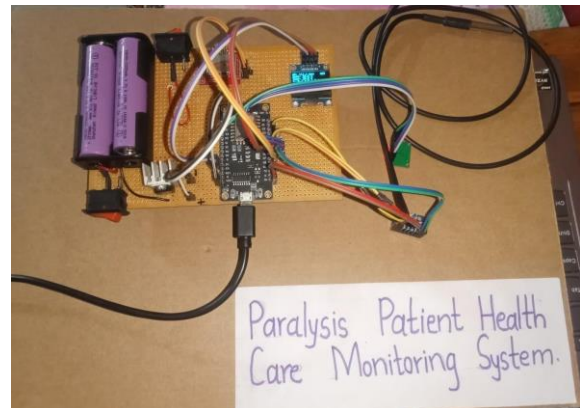

V. RESULT

VI. ADVANTAGES

- Continuous Health Monitoring
- Early Detection of Health Issues
- Emergency Alert System
- Remote Monitoring
- Reduced Caregiver Burden
- Improved Patient Safety
- Data Storage and Analysis
- Cost-Effective Solution
- User-Friendly Operation
- Enhanced Quality of Life

VII. LIMITATION

- Dependence on Internet Connectivity
- Power Supply Dependency
- Sensor Accuracy and Reliability
- High Initial Setup Cost
- Data Security and Privacy Risks

- Technical Complexity
- Limited Emergency Communication Ability
- Maintenance Requirements
- False Alarms

VIII. HARDWARE COMPONENTS LIST

- Heart Rate Sensor
- Temperature Sensor (LM35 / DS18B20)
- SpO2 Sensor
- Motion or Touch Sensor
- Microcontroller (Arduino / ESP32)
- GSM / Wi-Fi Module
- LCD Display
- Buzzer
- Power Supply Unit

IX. SOFTWARE COMPONENT LIST

- Embedded C / Arduino IDE
- IOT Cloud Platform
- Mobile or Web Application

X. FUTURE SCOPE

- Integration of AI and Machine Learning
- Wearable and Non-Invasive Devices
- Mobile Health (mHealth) Applications
- Telemedicine Integration
- Voice Recognition and Brain-Computer Interface (BCI)
- Blockchain Technology for Security
- Smart Home Automation Integration
- Enhanced Wireless Connectivity (5G)
- Long-Term Health Analytics
- Scalable and Cost-Effective Solutions

XI. CONCLUSION

The Paralysis Patient Health Care Monitoring System provides an innovative and efficient solution for continuously monitoring the health of patients suffering from paralysis. By integrating biomedical sensors, microcontroller-based processing, wireless communication, and emergency alert mechanisms, the system ensures real-time tracking of vital signs such as heart rate, blood pressure, body temperature, oxygen saturation (SpO₂), and patient movement.

This system significantly enhances patient safety by enabling timely medical intervention in critical situations while reducing the workload and stress on caregivers. Cloud-based data storage allows long-term health tracking, trend analysis, and informed clinical decisionmaking. The use of IoT and smart technologies ensures remote accessibility, making healthcare monitoring more convenient and effective, whether in hospitals or home environments.

Although there are limitations, such as dependency on network connectivity and power supply, the system offers a reliable, cost-effective, and user-friendly approach to patient care. With future advancements in AI, wearable devices, telemedicine, and smart home integration, the system has immense potential to further improve the quality of life, independence, and overall healthcare outcomes for paralysis patients.

In conclusion, the Paralysis Patient Health Care Monitoring System represents a significant step toward modern, technology-driven healthcare, combining continuous monitoring, rapid emergency response, and intelligent data management to provide comprehensive support for patients and caregivers alike.

REFERENCE

1. Biomedical Instrumentation – A detailed guide on biomedical sensors, data acquisition, and patient monitoring systems.
2. IoT-Based Health Monitoring Systems: A Review – Discusses IoT applications in real-time health monitoring.
3. World Health Organization – Global statistics and information on neurological disorders and paralysis.
4. Design and Implementation of Wireless Patient Health Monitoring System – Explains microcontroller-based health monitoring and wireless communication technologies.
5. Internet of Things for Healthcare Technologies – Covers IoT frameworks, cloud integration, and real-time monitoring in healthcare systems.
6. Emergency Alert Systems for Disabled Patients Using IoT – Focuses on emergency alert mechanisms for patients with limited mobility.
7. Smart Healthcare Systems Using Microcontrollers and IoT – Discusses the architecture and implementation of smart patient monitoring systems.

ACKNOWLEDGMENT

I would like to express my sincere gratitude to all those who supported and guided me throughout the development of the Paralysis Patient Health Care Monitoring System project.

First and foremost, I extend my heartfelt thanks to Ms.B.T.Chate ,whose expert guidance, valuable suggestions, and constant encouragement were instrumental in the successful completion of this project. Their insights and technical knowledge helped me understand complex concepts and implement the system efficiently.

I am also grateful to the faculty members of JAYWANTRAO SAWANT POLYTECHNIC

for providing the necessary resources, technical support, and laboratory facilities to carry out this work effectively.

Special thanks to my peers and friends who provided moral support, constructive feedback, and inspiration during the project work.

Finally, I acknowledge my family for their patience, understanding, and encouragement, which motivated me to complete this project successfully.

This project would not have been possible without the collective support, guidance, and inspiration from all the individuals mentioned above.