

# Design And Development Of Hydraulic Based Automated Dumper Bucket For Three Wheeler Electric Goods Carrier

Mr. Sunil S.D,  
Dept. of Mechanical Engineering,  
The National Institute of Engineering-Mysore

Asst. Prof. Shrinatha R Katti  
Dept. Of Industrial Automation and Robotics

**Abstract-**The current work involves developing a dumper bucket for an electric vehicle used to carry goods. The dumper bucket will be responsible for loading and unloading the goods efficiently. To achieve this, the project aims to automate the loading and unloading process based on the weight of the goods. The first step is to determine the requirements of the dumper bucket by considering the carrying capacity of the electric goods carrier and the type of materials it will transport. To enable easy tilting and unloading of the materials, a hydraulic system will be integrated into the dumper bucket. This hydraulic system will be powered by a battery mounted on the electric goods carrier. Safety features are incorporated, including a limit switch to prevent over-tilting of the bucket, ensuring safe operations. The final stage of the project focuses on automation. An Arduino UNO is used to develop a prototype model of the automated system. A load cell is employed to detect the applied load on the dumper bucket. Based on this load data, a buzzer and LED lights will be activated to provide warnings. Additionally, if the load exceeds the maximum limit, the system will cut off the power supply to the motor to prevent any unsafe conditions. Once the dumper bucket is fabricated and installed on the electric vehicle, it undergoes rigorous testing to verify that it can handle the required load capacity and operates safely. The aim is to create an efficient and secure system that automates the loading and unloading process for the electric goods carrier, enhancing its functionality and usability.

**Keywords-**Electric Goods carrier, Dumper bucket, hydraulic system, Arduino Uno, load cell sensor, LCD

## I. INTRODUCTION

In this background, this work has been taken up to develop an environmental friendly goods carrying process which can be automatically executed using a three wheeled goods carrier. Electric goods carriers represent a significant advancement in the transportation sector, aiming to address environmental concerns while offering efficient and cost-effective solutions for cargo transportation. These vehicles are designed to carry goods and materials without relying on traditional fossil fuels, making them an environmentally friendly alternative to conventional internal combustion engine-powered trucks. By harnessing the power of electricity, these vehicles reduce greenhouse gas emissions, noise pollution, and dependency on non-renewable resources, contributing to a cleaner and sustainable future.

The electric goods carrier involves several steps to ensure a safe and efficient system the first step in the design process is to determine the requirements of the dumper bucket. Weight capacity of the bucket, the size of the bucket, and the maximum angle at which the bucket can be tilted, are few of the parameters. The dumper bucket is designed by CAD software. This bucket used in

everywhere. This bucket is made by mild steel material. Because of this material is a popular choice for constructing heavy-duty equipment like dumper buckets due to its strength, durability, and relatively low cost. Mild steel provides good resistance to wear, impact, and abrasion, making it suitable for handling various materials in construction, mining, and other industries.

Additionally, mild steel can be easily fabricated and welded, allowing for the construction of complex shapes and structures, such as dumper bucket designs [1, 2 and 3]. The next step is design the chassis. The chassis is designed by based on the electric goods carrier dimensions. The chassis also made by material of the mild steel. Chassis is mounted between the bumper bucket and chassis of goods carrier. Why chassis is used in this project. Because of the chassis is supports to the dumper bucket. The dumper bucket is not shacked when the bucket is fixed with chassis [4, 5 and 6]. Once the requirements have been determined, the next step is to design the hydraulic system. This involves selecting the hydraulic components such as cylinders, valves, hoses, and pumps that will be used to power the dumper bucket. This is the most important step for actuate the dumper bucket and unloading the material. Basically hydraulic cylinder designed by standard

dimensions of the piston. The hydraulic system is operated by oil or fluid. In the case of a hydraulic cylinder, hydraulic fluid is pumped into one side of the cylinder, which creates pressure on the piston surface, forcing it to move linearly. The linear movement of the piston is then transferred to the piston rod, providing the desired force and motion. The hydraulic actuate motion and speed is control by the switch. A hydraulic cylinder is a mechanical actuator that converts hydraulic power into linear force and motion. It plays a crucial role in various industries and applications where powerful and controlled linear movement is required [7, 8 and 9].

The final stage of the project is to make the system capable of functioning on its own without human intervention. To achieve this, a prototype of the automated system is created using an Arduino UNO, a type of microcontroller board. In this automated system, a load cell is employed to detect the amount of weight or load applied to it. The load cell works based on a technology called "strain gauge principles," which is commonly used for measuring mass or weight. The purpose of using the load cell in this system is to monitor the weight of the material being transported. When the load cell senses that the weight exceeds a predetermined maximum limit, the system takes two actions. It activates a warning signal, which includes a buzzer and LED lights. This alert is to notify the operator or people nearby that the load has exceeded the safe limit. The system automatically cuts off the power supply to the motor.

This action stops the movement of the dumper bucket, ensuring that no further material is loaded or transported until the excess weight is removed and the system is reset. After constructing and installing the dumper bucket, the system undergoes thorough testing. The testing process is essential to verify that the dumper bucket can handle the specified load-carrying capacity without any safety risks. During testing, the load cell plays a vital role in simulating the transportation of materials, providing real-time feedback on the weight being carried. This automated system enhances safety and efficiency in material transportation by automatically alerting and preventing the operation when the load exceeds its safe capacity [10].

The load cell sensor is a type of mechanical sensor that is capable of detecting changes in pressure. It converts the pressure it senses into an electrical signal. In the context of the dumper bucket, the load cell sensor will be placed inside it to measure the weight of the materials loaded into the bucket. To process the data from the load cell sensor and determine the weight of the dumper bucket accurately, a microcontroller is required. The microcontroller acts as the brain of the system, taking the electrical signals from the load cell and performing the necessary calculations to obtain the weight information. To display relevant information to the user or operator, a 16x2 LCD (Liquid Crystal Display) is used. This display module is

commonly used in electronics projects and devices to show text-based information. It consists of two rows, each with 16 columns, allowing it to display up to 32 characters at a time. Interfacing the 16x2 LCD with the microcontroller is relatively simple, and it can be done using various communication protocols,

Such as 4-bit or 8-bit parallel interface or I2C (Inter-Integrated Circuit) interface. Once the 16x2 LCD is correctly connected and powered, the microcontroller can send commands and data to the display. Sending commands allows the microcontroller to control the display format, clear the screen, or set the cursor position. Sending data to the display enables the microcontroller to show specific characters or information at desired locations on the screen. Both the buzzer and LED are essential components in electronics, serving different purposes. Buzzer is a type of transducer that converts electrical energy into acoustic energy, creating audible sound waves. Buzzers are commonly used in various applications to provide audio alerts, notifications, or warning signals. LED, short for Light-Emitting Diode, is a semiconductor device that emits light when an electric current passes through it. LEDs are much more energy-efficient and durable. They come in various colors, including red, green, blue, yellow, and white. The both devices are used for the detecting warnings or errors of the weight or load. These devices are connect with the Arduino Uno board. Finally these components are work on the right program and it's detect the errors or warnings [11].

## II. COMPONENTS OF THE DEVICE

### 1. Structural Components:

#### A. Dumper Bucket:

Design of the dumper bucket [figure1] based on the original dimension of the goods carrier. The dumper bucket designed by the CAD software is used in the engineering industry for 3D modeling, simulation, and documentation. A dumper bucket, also known as a dump bucket or tipping bucket, is a type of attachment used in construction, and various other industries. It is typically attached to heavy machinery such as three wheeler goods carrier, excavators, loaders, or dump bucket.

The primary purpose of a dumper bucket is to transport and unload materials such as soil, gravel, sand and industries components. Dumper buckets are used to dig into the ground, scoop up soil, rocks, or other materials and then transport them to another location. They are commonly used in tasks such as digging foundations, creating trenches or clearing land by the dumper bucket [figure1]. Mild steel is a popular choice for constructing heavy-duty equipment like dumper buckets due to its strength, durability, and relatively low cost. Mild steel provides good resistance to wear, impact, and abrasion, making it suitable for handling various materials in

construction, mining, and other industries. Additionally, mild steel can be easily fabricated and welded, allowing for the construction of complex shapes and structures, such as dumper bucket designs. The dumper bucket is also designed to chassis dimensions for carry the goods. The dumper bucket is fixed with one end of chassis by the roller supports. The dumper bucket is fixed with the chassis and hydraulic cylinder.

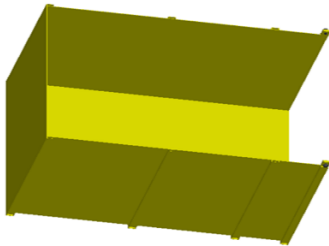

Figure1: dumper bucket

### B. Structure Of The Frame

The structure of the frame in a three wheeler goods vehicle serves as the structural framework that supports and holds together all the major components of the vehicle. The structure of the frame is mount between the goods chassis and dumper bucket [figure2]. Commonly mild steel material is used for made the chassis. Mild steel is a popular choice for constructing heavy-duty equipment like dumper bucket and structure of the frame due to its strength, durability, and relatively low cost. Mild steel provides good resistance to wear, impact, and abrasion, making it suitable for handling various materials in construction, mining, and other industries. Additionally, mild steel can be easily fabricated and welded, allowing for the construction of complex shapes and structures, such as design of dumper bucket and structure of the frame as shown in figure2.

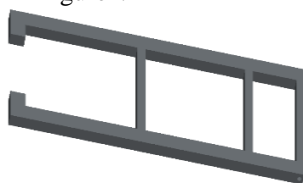

Figure2: structure of the frame

### C. Design Of Hydraulic System

A hydraulic cylinder is a mechanical actuator that converts hydraulic power into linear force and motion. It plays a crucial role in various industries and applications where powerful and controlled linear movement is required. The primary components of a hydraulic cylinder include a cylindrical barrel, a piston, a piston rod, and end caps as shown in figure3. The hydraulic cylinder works on the principle of Pascal's law, which states that any pressure applied to a confined fluid in a closed system will be transmitted equally in all directions. In the case of a hydraulic cylinder, hydraulic fluid is pumped into one side of the cylinder, which creates pressure on the piston surface, forcing it to move linearly. The linear movement

of the piston is then transferred to the piston rod, providing the desired force and motion.

- Pressure Conversion: The pressure value in bars is converted into kilograms per square centimetre ( $\text{kg}/\text{cm}^2$ ) by multiplying it by 1.02. For example, if the original pressure is 19 bars, then the converted pressure would be  $19 * 1.02 = 19.38 \text{ kg}/\text{cm}^2$ .
- Area Calculation: To find the area (A) of the piston, we use the formula  $A = \text{Force (F)} / \text{Pressure (P)}$ . In this case, the force applied is 1500kg, and the pressure is  $19.38 \text{ kg}/\text{cm}^2$ . So, the area would be  $A = 1500 / 19.38 = 77.39 \text{ cm}^2$ .

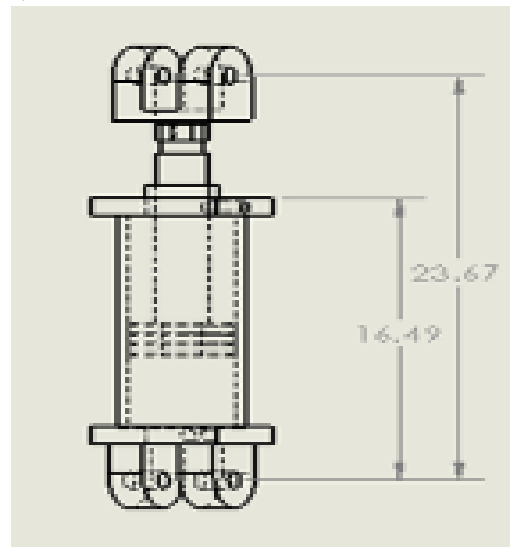

Figure3: draft sketch of cylinder

- Diameter Calculation: The area of the piston can also be calculated using its diameter (D) with the formula  $A = (\pi * D^2) / 4$ . By substituting the area value ( $77.39 \text{ cm}^2$ ) into the formula, we can solve for the diameter:  $D^2 = 98.5829$ , which means D is approximately 9.92 cm or 10 cm as shown in figure3.
- Velocity Calculation: The velocity (V) of the piston is determined by dividing the stroke length (L) by the time taken for one complete stroke (t). If the stroke length is 24 units and the time for one stroke is 120 seconds, then the velocity would be  $V = 24 / 120 = 0.2 \text{ cm}/\text{s}$ .
- Flow Rate Calculation: The flow rate (Q) of the piston is found by multiplying the piston's area (A) by its velocity (V). Given that the area is  $77.39 \text{ cm}^2$  and the velocity is  $0.2 \text{ cm}/\text{s}$ , the flow rate would be  $Q = 77.39 * 0.2 = 15.478 \text{ cm}^3/\text{s}$ .
- Horsepower Calculation: Finally, to calculate the horsepower (HP) generated by the piston, we use the formula  $\text{HP} = (\text{Pressure} * \text{Flow Rate}) / 1714$ . Plugging in the values, where pressure is  $19.38 \text{ kg}/\text{cm}^2$  and the flow rate is  $15.478 \text{ cm}^3/\text{s}$ , the horsepower would be  $\text{HP} = (19.38 * 15.478) / 1714 = 0.174 \text{ HP}$ .

These calculations determine the piston's area, diameter, velocity, flow rate, and horsepower based on the given pressure, force, stroke length, and time. The values are

expressed in standard units such as  $\text{kg/cm}^2$ ,  $\text{cm/s}$ , and  $\text{cm}^3/\text{s}$ .

## II. ELECTRIC COMPONENTS

### 2.1. Battery System

Lithium Iron Phosphate (LiFePO<sub>4</sub> or LFP) battery with a nominal voltage of 72 volts and a capacity of 100 ampere-hours (AH). Lithium Iron Phosphate batteries are a type of rechargeable lithium-ion battery known for their safety, long lifespan, and relatively stable performance across a wide range of temperatures in as shown in figure4. They have gained popularity in various applications, including electric vehicles, renewable energy storage systems, and portable electronics.

The working principle of an LFP battery [figure4] is based on the movement of lithium ions between the positive (cathode) and negative (anode) electrodes during charging and discharging cycles. When the battery is charged, lithium ions move from the cathode to the anode through an electrolyte. During discharging, the process is reversed, and lithium ions move back from the anode to the cathode, generating electrical energy in the process. The use of Lithium Iron Phosphate chemistry in these batteries provides several advantages over other lithium-ion technologies. It offers better thermal stability, reducing the risk of overheating and thermal runaway. Additionally, LFP batteries are less prone to degradation and can withstand a higher number of charge-discharge cycles, leading to an extended lifespan compared to other lithium-ion battery types.

The high voltage (72V) and capacity (100AH) of the battery make it suitable for use in various high-power applications, such as electric vehicles, large-scale renewable energy systems, and industrial equipment, so it's always essential to refer to the latest specifications and documentation provided by the battery manufacturer for the most accurate and up-to-date information.



Figure4:LFP-battery

### 1.2 Development Of Automated System And Components:

**Define the Problem:** Clearly identify the task or problem to automate using Arduino Uno. **Gather Components:** Identify and acquire the necessary components such as

load cell sensor, LCD, LED, buzzer and other electronic parts. **Plan and Design:** Create a schematic or block diagram of system to visualize the connections and interactions between components. **Setup Arduino IDE:** Install the Arduino IDE on computer, which allows us to write, compile, and upload code to the Arduino Uno. **Write the Code:** Use Arduino programming language (based on C/C++) to write the code that controls the inputs and outputs of the system. **Connect the Components:** Physically connect the sensors, LCD, LED, buzzer, and other components to the appropriate pins on the Arduino Uno. **Upload the Code:** Connect the Arduino Uno to computer and upload the code from the Arduino IDE to the board. **Test and Debug:** Verify the functionality of the automated system, test each component, and iterate on the code to fix any issues.

### 1.Arduino Uno Board

Arduino Uno is a popular microcontroller board based on the ATmega328P microcontroller which offers 32KB of flash memory for program storage, 2KB of SRAM for data storage, and 1KB of EEPROM for non-volatile data storage. It is part of the Arduino family of development boards, designed to provide an accessible platform for creating and prototyping electronic projects. Arduino Uno has a set of digital input/output (I/O) pins (14 digital pins) as shown in figure5, that can be used for tasks such as reading sensors, controlling actuators, or communicating with other digital devices.



Figure5: arduinouno

It also includes a set of analog input pins (6 analog pins) that can read analog signals from sensors or other analog devices. Arduino Uno supports serial communication through USB and UART (Universal Asynchronous Receiver/Transmitter). It has a USB interface for programming and communication with a computer, and it also has dedicated RX and TX pins [figure5] for UART communication. Arduino Uno is programmed using the Arduino Software (IDE), which is based on a simplified version of C and C++. The IDE provides an easy-to-use interface for writing, uploading, and debugging code.

### 2.Load Cell Sensor

A load cell is a transducer that converts a mechanical force or load into an electrical signal. Load cell sensors typically

consist of a metal or alloy structure that deforms when subjected to force or load. The deformation causes a change in the electrical resistance, strain, or capacitance of the load cell, which is then converted into an electrical signal proportional to the applied force. It is commonly used in various applications to measure and monitor forces or weights. The load cell's electrical output is proportional to the applied force, allowing for accurate measurement and monitoring. This device is very important to measure the load of the dumper bucket. Load cell sensors are widely used in various industries such as manufacturing, automotive, aerospace, and healthcare. They provide accurate and reliable measurements, making them essential for tasks like weighing, force testing, and load monitoring.

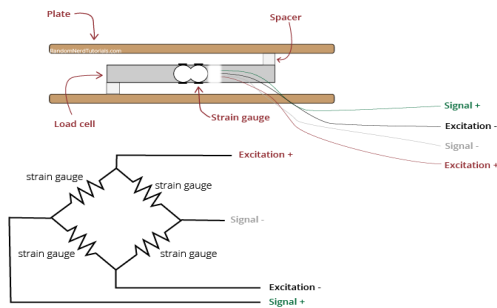

Figure6: load cell sensor

**Working Principle:** Load cells are typically based on various technologies, such as strain gauge, hydraulic, pneumatic, or capacitive. The most common type is the strain gauge load cell, which uses strain gauges attached to a metallic structure. When a force is applied to the load cell, it deforms the structure, causing a change in the electrical resistance of the strain gauges. This change is measured and converted into an electrical signal. **Types of Load Cells:** Load cells come in different types depending on the specific application and force measurement requirements. Some common types include compression load cells, tension load cells, shear beam load cells, bending beam load cells, and S-type load cells. Each type has its own design and is suitable for different load conditions. **Range and Accuracy:** Load cells are available in a wide range of capacities, from a few grams to several thousand tons. The accuracy of a load cell is typically specified as a percentage of the full-scale load and can vary depending on the quality and design of the load cell.

### 1.LCD (LIQUID CRYSTAL DISPLAY):

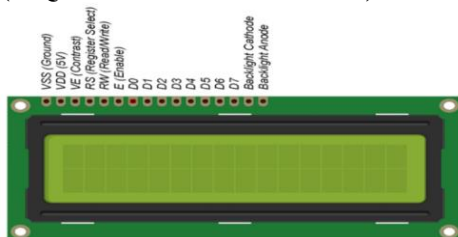

Figure7: liquid crystal display

A 16x2 LCD display refers to a liquid crystal display with a character capacity of 16 columns and 2 rows, resulting in a total of 32 characters that can be displayed at a time. Each character space is typically 5x8 pixels in size. These displays are commonly used for displaying alphanumeric characters and simple symbols. The 16x2 LCD display is widely used in various electronic devices and embedded systems for providing textual information and user interaction. It is extensively used in microcontroller-based projects and embedded systems for providing a user interface. It can display status messages, menus, prompts, and sensor readings, allowing users to interact with the system. Arduino enthusiasts often utilize 16x2 LCD displays in their projects. They can display sensor data, control parameters, and provide visual feedback, expanding the capabilities of Arduino-based systems. LCD displays find application in home appliances such as washing machines, microwaves, air conditioners, and refrigerators. They can show settings, timers, temperature readings, error messages, and other relevant information.

### 2.Buzzer



Figure8: buzzer

A buzzer is an electronic device that produces a continuous or intermittent sound. Buzzers are typically composed of a housing, an electromagnetic coil, and a diaphragm or piezoelectric element. There are different types of buzzers available, including electromagnetic buzzers, piezoelectric buzzers, and magnetic buzzers. Each type generates sound using different principles as shown in figure8. Buzzers are often employed as warning devices to indicate critical situations or safety hazards.

They can be found in industrial equipment, vehicles, and machinery to alert operators of potential dangers or malfunctioning. In the medical field, buzzers are employed in devices like patient monitors, medical alarms, and healthcare equipment. They help alert medical professionals to critical events or abnormal conditions. Buzzer construction can vary depending on the specific design and purpose, but typically it consists of a coil, an armature, and a diaphragm. When an electric current is applied to the coil, it generates a magnetic field that attracts the armature towards it. This movement causes the diaphragm to vibrate or oscillate, producing sound waves that result in an audible buzzing or beeping sound.

## 1.LED

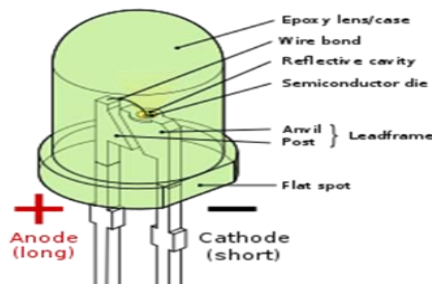

Figure9: LED

LED stands for Light-Emitting Diode. It is a semiconductor device that emits light when an electric current passes through it. To use an LED with an Arduino Uno, you typically connect one leg of the LED (the cathode, indicated by a shorter leg or a flat side) to a digital pin of the Arduino Uno board as shown in figure 9. The other leg (the anode) is connected to a current-limiting resistor and then to the ground (GND) pin of the Arduino. By controlling the voltage applied to the digital pin, you can turn the LED on and off or vary its brightness. LEDs provide a simple and effective way to provide visual feedback and indication in Arduino projects. They can be used to indicate the status of a process, signal the occurrence of an event, or display the output of a sensor. LEDs are often used in educational settings or for prototyping purposes with Arduino Uno boards. They provide a hands-on and visual way to understand basic electronics concepts, such as digital output, binary logic, and controlling components through code.

## III. RESULTS AND DISCUSSION

The project design and development of hydraulic-based automated dumper bucket for a three-wheeler electric goods carrier has been successfully completed. The main objective of the project was to create an efficient and safe system that automates the loading and unloading process based on the weight of the goods being transported figure 10.

General explanation of how the final result of a dumper bucket would typically function in a dumper bucket. Loading: The dumper bucket is used to load materials onto the dumper bucket. It can be filled at a construction site, excavation area, or any location where materials need to be moved. Transport: Once the dumper bucket is loaded, the dumper bucket drives to its destination or a designated dump site. The bucket keeps the materials securely contained during transport. Unloading: At the destination or dump site, the truck's hydraulic system is activated to tilt the dumper bucket, allowing the contents to slide out and be deposited on the ground. The tilting mechanism can be operated from inside the dumper bucket, making the unload process efficient and convenient. Repeating the Process: After unloading, the dumper bucket returns to its

original position, and the truck can be reloaded for another cycle of transportation and unloading. The final result of the dumper bucket's operation is the successful and efficient transportation and unload of bulk materials, making it an essential component in various industries dealing with heavy loads and loose materials. When a dumper truck is loaded with material, the dumper bucket is in a raised position, allowing the materials to be contained within the bucket. Once the truck arrives at the desired location for unloading, the operator initiates the dumping process. The dumper bucket is hydraulically or mechanically tipped backward, allowing the contents to be discharged out of the back of the dumper bucket.

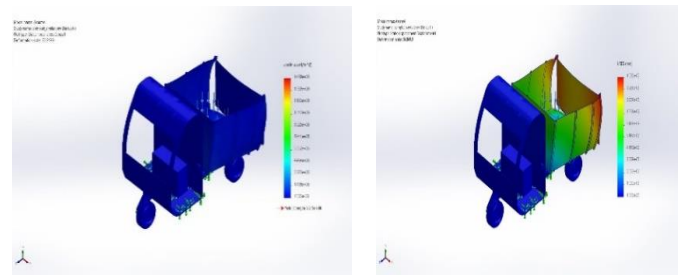

Figure10: simulation of dumper bucket

The project has successfully achieved its objectives and demonstrated the feasibility of automating the load and unload process for the three-wheeler electric goods carrier. The hydraulic-based dumper bucket system proved to be effective in tilting and unloading materials, enhancing the carrier's efficiency and productivity.

The automated weight measuring system has been successfully completed. The system utilizes a load cell sensor to measure the weight, and the data from the load cell sensor is sent to the HX711 ADC amplifier. The HX711 amplifier converts the analog signals from the load cell into digital signals. These digital signals are then transmitted to a microcontroller [figure 11]. The microcontroller is responsible for processing all the data received from the load cell and other components. After processing the data, the microcontroller sends the results to a Liquid Crystal Display (LCD).

The LCD used in the system is a standard 16-column and 2-row display, commonly employed for displaying alphanumeric characters and simple symbols. The LCD displays the measured weight results in a clear and readable format. It allows the user to easily view the weight readings and take necessary actions based on the displayed values. The integration of a load cell with the system allows for real-time monitoring of the applied load. The buzzer and LED indicators were used as safety features to warn the operator when the load approaches or exceeds the specified limit as shown in [figure 11]. This ensures that the goods carrier is not overloaded, preventing potential damage to the vehicle and ensuring safe

operations. This system automation significantly reduces the manual effort required for loading and unloading, making the process more user-friendly and efficient. With the automated dumper bucket, the goods carrier can handle different types of materials with varying weights, making it versatile for various transportation needs. During the testing phase, the system demonstrated consistent and reliable performance, accurately measuring the weights and responding appropriately with the activation of the buzzer and LED indicators when necessary.

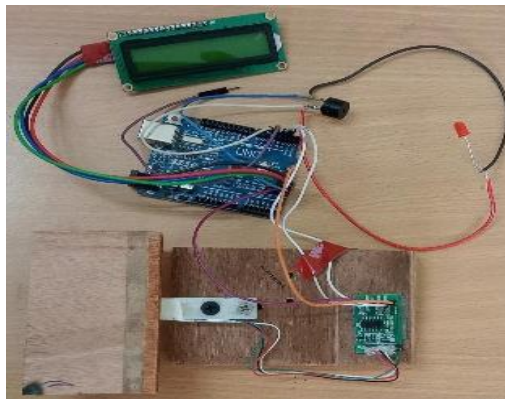

Figure 11: circuit connection

Table 1 Result's

SL. NO.	ITEMS	WEIGHT	ERROR	buzzer	LED
1	sand	400gm	3.2gm	ON	ON
2	sugar	200gm	1.6gm	OFF	OFF

In the above results table, we have two items listed: sand and sugar, along with their respective weights and the errors in their measurements. These items are being tested with the automated system, which includes a load cell, buzzer, and LED.

**Sand:** When a load of 400 grams is applied to the system, the actual weight measured by the load cell is 403.2 grams (with an error of 3.2 grams). As a result, both the buzzer and LED are activated, indicating that the load has reached or exceeded the specified limit. However, when the load is below 400 grams, the buzzer and LED remain OFF, indicating that the weight is within the acceptable range.

**Sugar:** When a load of 200 grams is applied, the load cell measures the actual weight as 201.6 grams (with an error of 1.6 grams). Since this weight is below the limit of 400 grams, both the buzzer and LED remain OFF, indicating that the load is within the acceptable range.

This concept of using the load cell, buzzer, and LED to monitor and control the load is an essential part of the major project, which involves designing and developing a hydraulic-based automated dumper bucket for a three-wheeler electric goods carrier. By implementing this concept, the automated dumper bucket will be able to detect and handle different loads efficiently and safely. It

will provide warnings (activating the buzzer and LED) when the load exceeds the set limit, ensuring the smooth operation of the goods carrier and preventing any potential risks associated with overloading.

#### IV. CONCLUSION

The successful design and development of the hydraulic-based dumper bucket for the three-wheeler electric goods carrier significantly improves its cargo-handling capabilities, making it a practical and valuable solution for businesses and logistics companies. This innovation represents a step forward in the field of electric goods transportation and has the potential to positively impact the industry by streamlining operations and reducing manual labor. This project offers significant advantages and improvements to the traditional manual loading and unloading processes. Through this project, a more efficient and convenient solution has been achieved to enhance the cargo-carrying capabilities of the vehicle. This not only reduces the physical strain on the operator but also increases the overall productivity and efficiency of goods transportation. The hydraulic system allows for precise control of the dumping process, ensuring smooth and stable operations. The incorporation of safety features enhances the operator's confidence and minimizes the risk of accidents during loading and unloading. This project is more efficient and convenient solution has been achieved.

#### REFERENCES

- [1] Three Directional Dumping System for trolley/dumper: A Proposed work S. N. Waghmare<sup>1</sup>, N. J. Kamble<sup>2</sup>, A. S. Dhamankar<sup>2</sup>, A. A. Shinde<sup>2</sup>, A. D. Vishwasrao<sup>2</sup> (Mechanical Engineering Department, Rmcet, Ambav, India).
- [2] Universal Modern Trailer: A Review Prof. R.S. Ambade, Shubham D. Navghare, Bhushan S. Kamatkar Jawaharlal Darda Institute of Engineering & Technology, Yavatmal.
- [3] Mr. Abhimanyu D. Deshmukh, Mr. Vivek R. Patil, Mr. Vivek S. Chavan, Mr. Mahesh M. Kadam, Mr. Dipak M. Bhosale Department of Mechanical Engineering Adarsh Institute of Technology & Research Centre Vita Tal Khanapur, Dist- Sangli, Maharashtra 3-Way Hydraulic Dumping Trolley IJSRD - International Journal for Scientific Research & Development | Vol. 4, Issue 12, 2017 | ISSN (online): 2321-061
- [4] Mr. Sachin M. Shinde<sup>1</sup>, Mr. Karan N. Dehade<sup>2</sup>, Mr. Pravin D. Chavan<sup>3</sup>, Mr. Shubham D. Khanzode<sup>4</sup>, Mr. Parmeshwar P. Mhaske<sup>5</sup>, Mr. Akash R. Tale<sup>6</sup>, "Review on Three Way Dumping Trolley". Department of Mechanical Engineering 1,2,3,4,5,6, Pankaj Laddhad Institute Of Technology, Tq, Buldhana, Dist, Buldhana, Maharashtra, UG Student 1,,2,3,4,5,6 Email: shindesachin8956@gmail.com

- [5] AmbojiSudhakar, R.HumaneYogesh, A.Chavan Rohan, R.PatilJyotsna C and KshirsagarPrashant R., Design and Fabrication of Three Way Tipper Mechanism, International Journal of Research in Advent Technology, 2(4), 2014, 2321-9637.
- [6] N.Eswara Prasath<sup>1</sup>, S.Shanmugam<sup>2</sup>, C.Mathalai Sundaram<sup>3</sup>, A.VembathuRajesh<sup>4</sup>, development of three axes lifting modern trailer. 1Mechanical Engineering, Sethu Institute of Technology, Kariapatti, 2
- [7] Sri Sowdambika Polytechnic College, Aruppukkottai Tamil Nadu, India 3&4Mechanical Engineering, NadarSaraswathi College of Engineering & Technology, Theni, Tamil Nadu, India #Corresponding author's mail id: avr.krj@gmail.com.
- [8] Siva Subramanian S<sup>1</sup>, Anandhu G K<sup>2</sup>, Adarsh P<sup>3</sup>, Joshua O<sup>4</sup>, Logeshwaran K<sup>5</sup>, Assistant Professor (1), UG Scholar (2,3,4,5). "Design and Fabrication of Three Way Tipper Mechanism". Mechanical Department Hindusthan Institute Of Technology, Coimbatore, Tamilnadu, India-641032.
- [9] "Design and fabrication of modern three way dumping trolley mechanism", P. Shashidar<sup>1</sup>, P. Laxminagaprasad<sup>2</sup>, U. Anil Kumar<sup>3</sup>. [1,2,3] Mechanical Engineering, Sri Venkateswara Engineering College.
- [10] "Design of an intelligent electronic system for dump truck tip-over prevention" Chin Leei Cham, Wooi Haw Tan, Faculty of Engineering, Multimedia University, Malaysia.
- [11] FahmiFahmi: Department of Electrical Engineering, Faculty of Engineering, University of Sumatera Utara, Jl. Simulation of Waste Transport Monitoring Based on Garbage Load Capacity using Load Cell. Dr. Mansur 9 Medan 20155, Indonesia Correspondence.