

Advancements in Cmos Lc Vco Design for Radio Frequency Applications: A Comprehensive Review

M.Tech.Scholar Jyanti lodhi

Dept of Electronics and Communication Engineering
Eklavya university,Damoh,mp,India

Abstract- This paper delves into the examination of various topologies employed in the design of CMOS LC VCOs, with a specific focus on achieving lower power consumption and reduced phase noise. Four distinct topologies were investigated and compared based on their power consumption and phase noise characteristics. The results of this comparative analysis reveal that the CMOS LC VCO with pseudo resistance exhibits the lowest phase noise, while the differential cross-coupled CMOS LC VCO demonstrates superior power efficiency. Among the studied topologies, the cross-coupled differential LC VCO topology emerges as a popular choice for optimizing the trade-off between phase noise and power consumption. By leveraging this topology, designers can strike a balance between these competing factors, leading to improved performance in practical applications.

Keywords- Voltage Controlled oscillator (VCO), phase noise, tuning, power consumption, CMOS.

I. INTRODUCTION

Oscillators play a critical role as fundamental building blocks in communication systems, serving as a reliable source of periodic signals. Among various oscillator types, Integrated LC tank Voltage Controlled Oscillators (VCOs) hold significant importance in fully integrated transceivers, as they provide essential input for signal up-conversion and down-conversion in mixers. To ensure optimal performance, VCOs must meet three key criteria: proper amplitude, low power consumption, and low phase noise [1]. In recent years, voltage controlled oscillators (VCOs) designed using CMOS technology has emerged as a practical solution for radio frequency applications.

This is primarily due to their advantageous attributes of low power consumption and low phase noise values. Designers are increasingly inclined towards the utilization of LC-VCOs, as they offer an optimal combination of exceptionally low phase noise specifications and minimal power consumption, making them suitable for battery-operated devices. The demand for improved performance in communication systems has driven extensive research and development efforts towards designing CMOS-based LC VCOs that can effectively meet the stringent requirements of modern transceivers.

Achieving high performance while minimizing power consumption and maintaining low phase noise levels has become a key focus for VCO designers. This paper aims to explore and evaluate various topologies and techniques employed in CMOS LC VCO design to achieve the desired performance metrics. By analyzing

the trade-offs between power consumption, phase noise, and other important factors, this study aims to provide insights into the selection and optimization of LC-VCO designs for radio frequency applications.

II. FEEDBACK MODEL OF OSCILLATOR

Oscillator are nonlinear in nature, though are usually viewed as a linear time invariant feedback system as shown in Figure 1. In the s-domain, the transfer function of this negative feedback system is given by

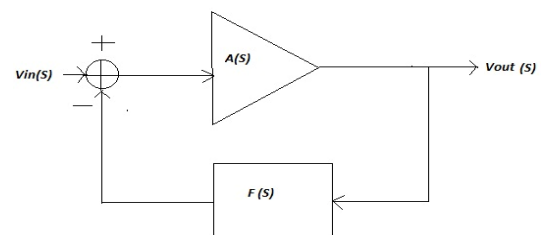

Fig.1. Negative feedback system with frequency selective network.

$$V_{in} \quad 1 + A(s)F(s)$$

If the loop gain $A(s)F(s)$ is equal to -1 at a specific frequency ω_0 , the closed loop gain approaches to infinity. Under this condition, the feedback becomes positive and the system tends to be not stable. Separating the magnitude and the phase of $A(s)F(s)$, the well-known “Barkhausen criteria” are obtained for the oscillation start-up. The Barkhausen Criteria for oscillation is

Compulsory but not sufficient [1].

3. LC Tank VCO Topologies

The Voltage Controlled Oscillator (VCO) holds a crucial position as an essential building block in transmitter circuits, playing a pivotal role in determining the overall phase noise, also referred to as jitter, performance. In the realm of VCO design, achieving lower phase noise, lower power consumption, and an optimal figure of merit (FOM) are the primary objectives to ensure the desired performance. Phase noise, which quantifies the fluctuations in the oscillation frequency, is a critical parameter in modern communication systems.

It directly impacts the quality of the transmitted signal, particularly in applications that require high data rates and reliable signal synchronization. By minimizing phase noise, VCO designers aim to enhance the signal quality, reduce interference, and improve the overall system performance. Power consumption is another crucial aspect to consider in VCO design. With the increasing demand for portable and battery-operated devices, power efficiency has become a key concern. Designers strive to minimize the power consumed by the VCO while maintaining its functionality and performance. Lower power consumption not only extends the battery life but also helps mitigate heat dissipation issues in integrated circuits.

Furthermore, the figure of merit (FOM) is a metric that combines the key design objectives of a VCO, namely phase noise and power consumption, into a single performance parameter. The FOM provides a comprehensive measure of the VCO's efficiency and effectiveness. Designers aim to achieve the best possible FOM, indicating superior trade-offs between phase noise and power consumption. By optimizing the FOM, VCO designers can deliver high-performance oscillators that meet the stringent requirements of modern communication systems.

In summary, the design of a Voltage Controlled Oscillator (VCO) revolves around achieving lower phase noise, lower power consumption, and the best figure of merit (FOM). By focusing on these design objectives, VCO designers aim to enhance signal quality, ensure power efficiency, and deliver optimal performance in various communication applications.

3.1 Differential cross coupled LC tank VCO In the design of Voltage Controlled Oscillators (VCOs), the selection of circuit topologies and component choices plays a crucial role in achieving desirable performance characteristics. In a particular study [7], a differential cross-coupled LC tank VCO with a decoupled capacitor and a polysilicon resistor (R_s) was utilized to address the objectives of reducing power consumption and phase noise. The inclusion of a decoupled capacitor in the VCO design helps to mitigate the power consumption without compromising the overall performance. By effectively

decoupling the capacitor from the main tank circuit, unnecessary power dissipation is minimized, leading to improved power efficiency. This approach is particularly valuable in applications where power consumption is a critical concern, such as portable devices or energy-efficient systems. Additionally, the use of a P-MOSFET in the cross-connected pair of the VCO aids in reducing phase noise. Flicker noise, which can significantly degrade the overall performance of the oscillator, is effectively mitigated with the implementation of the P-MOSFET. The reduced flicker noise contributes to a cleaner output signal and improved phase noise characteristics, resulting in enhanced system performance. Moreover, the polysilicon resistor R_s incorporated in the VCO design offers the advantage of being nearly $1/f$ noise-free. This is beneficial in achieving lower phase noise since $1/f$ noise, also known as flicker noise or pink noise, can have a detrimental impact on the performance of the VCO. By utilizing a resistor with minimal $1/f$ noise, the overall phase noise performance is improved, leading to a more stable and reliable oscillation signal.

The combination of the aforementioned design choices, including the incorporation of a decoupled capacitor, the use of a P-MOSFET, and the inclusion of a low $1/f$ noise polysilicon resistor (R_s), contributes to the overall success of the VCO design. By carefully selecting these components and implementing them within the differential cross-coupled LC tank VCO topology, the study aimed to achieve a balance between reduced power consumption and improved phase noise performance. In conclusion, the utilization of a differential cross-coupled LC tank VCO with a decoupled capacitor, a P-MOSFET, and a low $1/f$ noise polysilicon resistor (R_s) represents a valuable approach in VCO design. This combination allows for the reduction of power consumption while simultaneously improving phase noise characteristics. Such design choices contribute to the overall performance and efficiency of VCOs in various communication applications.

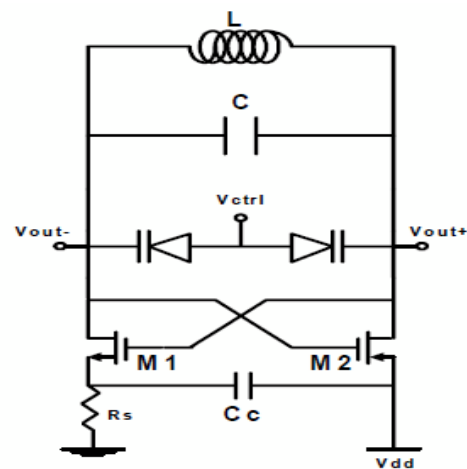

Fig.2. Cross coupled differential topology

3.2 Complimentary cross coupled LC tank VCO The utilization of complementary differential transistor pairs in

VCO design offers several advantages, including the ability to produce twice the negative resistance compared to single differential transistor pairs. This increased negative resistance is beneficial for enhancing the oscillation amplitude and managing power limitations [8]. In the context of a complementary cross-coupled LC tank VCO, the design incorporates two LC tank VCOs, each utilizing a different current mirror configuration. One LC tank VCO employs an NMOS current mirror, while the other uses a PMOS current mirror.

The purpose of this configuration is to compare the phase noise performance between the two circuits while keeping the tail current constant. After conducting the phase noise comparison, it was observed that the circuit designed with the PMOS current mirror exhibits lower phase noise in comparison to the circuit designed with the NMOS current mirror. This finding suggests that the PMOS current mirror configuration offers improved phase noise performance, making it a preferable choice for achieving better signal quality and stability in the VCO. The disparity in phase noise performance between the two circuits can be attributed to several factors. The PMOS current mirror configuration may offer superior current matching characteristics and reduced flicker noise, resulting in improved phase noise performance.

Additionally, the inherent characteristics of PMOS transistors, such as lower flicker noise and improved thermal noise performance, can contribute to the observed lower phase noise. By carefully selecting the appropriate current mirror configuration, in this case, utilizing the PMOS current mirror, designers can optimize the phase noise performance of the VCO while maintaining a constant tail current. This optimization leads to improved overall signal quality, reduced interference, and enhanced performance in communication systems.

In summary, the use of complementary differential transistor pairs in VCO design provides benefits such as increased negative resistance. In the context of a complementary cross-coupled LC tank VCO, comparing the phase noise performance of circuits utilizing different current mirror configurations revealed that the PMOS current mirror configuration offers lower phase noise compared to the NMOS current mirror configuration. By leveraging the advantages of the PMOS current mirror, designers can achieve improved phase noise performance and enhance the overall quality and stability of the VCO's output signal.

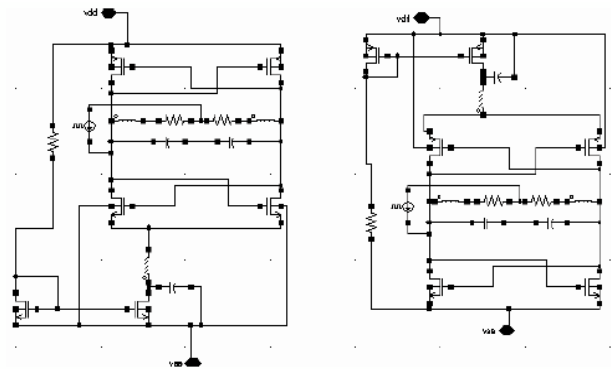

Fig.3. Complimentary cross coupled LC tank VCO.

3.3 Cross coupled LC tank VCO with double Pseudo resistance

In this study, a VCO with double pseudo resistance was designed to achieve low power consumption while preserving phase noise performance. The phase noise of a VCO, specifically a LC-VCO, is inversely proportional to the quality factor (Q) of the LC-tank [9]. However, CMOS inductors commonly used in RF circuits often exhibit a low quality factor. To address this issue and improve phase noise, the Q of the LC-tank needed to be increased. To achieve this objective, the proposed LC-VCO employed an added negative transconductance technique. Four capacitors (C1 to C4) were introduced in parallel with the drain-source of NMOS and PMOS cross-coupled transistors. The addition of these capacitors introduced negative transconductance, which effectively reduced the overall transconductance of the circuit.

This reduction in transconductance resulted in an increase in the quality factor of the LC-tank, thereby improving the phase noise performance. The primary goal of this technique was to decrease the power consumption of the VCO. To achieve this, two resistances were added to the VCO in the power supply path. These resistances were implemented using two pairs of PMOS and NMOS transistors operating in the triode region. By functioning as resistances in the circuit, these transistor pairs contributed to reducing power consumption. By integrating the double pseudo resistance technique into the VCO design, the study aimed to achieve a balance between low power consumption and improved phase noise performance.

This technique effectively increased the quality factor of the LC-tank while simultaneously reducing power consumption by utilizing resistances in the power supply path. In summary, the design of the VCO involved the incorporation of double pseudo resistance to achieve low power consumption without compromising phase noise performance. By introducing negative transconductance through the addition of capacitors and incorporating resistances in the power supply path, the study aimed to

enhance the quality factor of the LC-tank and reduce power consumption. This approach enabled the VCO to maintain optimal phase noise performance while achieving lower power consumption, thus contributing to the overall efficiency of the VCO design.

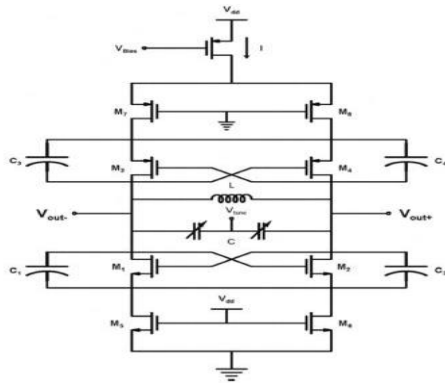

Fig.4. Cross coupled LC tank VCO with double Pseudo resistance.

3.4 Quadrature VCO using Reconfigurable LC tank

The utilization of a Quadrature Voltage Controlled Oscillator (VCO) is of significant importance in multi-standard and multi-band transceiver systems [10]. This specific type of VCO offers the advantages of low phase noise while maintaining low current consumption, making it highly suitable for such applications. A key feature that enables dual-band operation in the Quadrature VCO is the integration of a reconfigurable LC tank. The LC tank, which consists of inductors and capacitors, plays a vital role in determining the oscillation frequency of the VCO. By employing a reconfigurable LC tank, the VCO can adapt to different frequency bands, enabling its use in multi-band transceiver systems. The adoption of a reconfigurable LC tank allows the Quadrature VCO to support the operation in multiple frequency bands without requiring separate VCO designs for each band.

This approach offers significant advantages in terms of reducing design complexity, circuit size, and power consumption. It enables a more flexible and versatile transceiver system that can cater to different frequency bands and standards. In addition to its reconfigurability, the Quadrature VCO is specifically designed to deliver low phase noise. Phase noise is a critical parameter in communication systems as it directly impacts signal quality and system performance. By achieving low phase noise levels, the Quadrature VCO ensure improved signal integrity, reduced interference, and enhanced overall system performance. Moreover, the Quadrature VCO's ability to maintain low current consumption is of great significance, particularly in power-constrained applications such as portable devices. The low current

consumption helps to extend battery life, reduce power dissipation, and enhance the overall energy efficiency of the transceiver system. In summary, the Quadrature VCO serves as a crucial component in multi-standard and multi-band transceiver systems. Its utilization of a reconfigurable LC tank enables dual-band operation, allowing it to adapt to different frequency bands without the need for separate VCO designs. Additionally, the Quadrature VCO provides low phase noise and low current consumption, ensuring high-performance signal generation while maintaining energy efficiency.

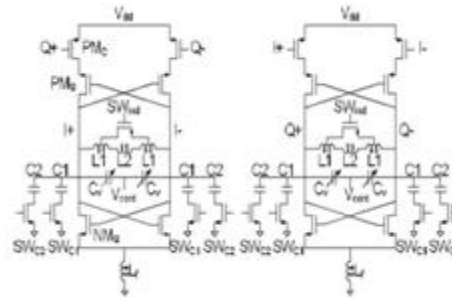

Fig.5. Quadrature VCO using Reconfigurable LC tank

4. Voltage Controlled Frequency Tuning

Most wireless applications require a tunable oscillator, which means its output frequency is a function of a control input, usually a voltage. An ideal VCO is a circuit whose output frequency is a linear function of its control voltage (V_{con}) [3], as shown in Figure 6

$$f_{out} = f_0 + K_{VCO} \cdot V_{con}$$

where, f_0 is the oscillation frequency at $V_{con} = 0$ and K_{VCO} represent the gain or sensitivity of the circuit. The achievable range of frequency, $f_2 - f_1$, is called the frequency tuning range.

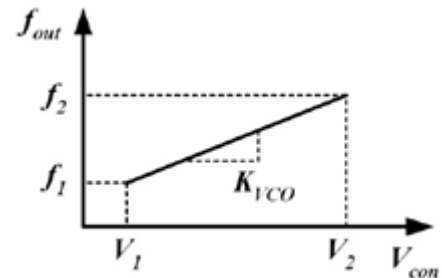

Fig.6. Definition of K_{VCO}

Frequency tuning is required not only to cover the whole application bandwidth but also to compensate for variations of the center frequency of the VCO that are

caused by the process and by temperature.

5. Power Consumption

Mobile devices are required to have long standby times, indicating a need for low power consumption. Phase noise is inversely proportional to the power dissipated in the resistive part of the resonant LC tank. This seems to suggest that an arbitrarily small phase noise can be achieved by simply increasing the bias current, but there are practical limitations as to how small phase noise can be made. As bias current is increased, so is the VCO's output voltage amplitude. However, any CMOS transistor has a maximum voltage that cannot be exceeded without permanent damage [6]. The voltage amplitude of the tank for the CMOS cross-coupled differential topology shown can be expressed by assuming that the differential stage switched from one side to the other [6]. As the tank voltage changes, the direction of the current flow through the tank reverses. The differential pair can be modeled as a current source switching between I_{total} and $-I_{total}$ in parallel with an RLC tank. R_{eq} is the equivalent parallel resistance of the tank. The tank amplitude can be approximated as $V=I_{tot} \cdot R_{eq}$.

This is referred to as the current-limited operation because tank amplitude mainly depends on the total current flowing and the tank's equivalent resistance. However, equation (11) becomes invalid when the tank amplitude becomes the supply voltage through an increase of I_{total} . This operation is called the voltage-limited operation. With current limited operation, as the current increases (consuming more power), the phase noise lowers because the tank amplitude is increasing simultaneously.

VII. COMPARISON AND DISCUSSION

A comparison of this work with previous wide-tuning range design is shown in Table given below. From this comparison table, it is seen that cross coupled differential LC VCO topology has low power consumption and high frequency.

Table I. Comparison Of Parameter

S.No	Parameter	Ref [24]	Ref.[25]	Ref.[28]	Ref.[21]	Ref.[41]	Ref.[27]	Ref.[29]	Ref.[20]	Ref.[31]	Ref.[33]
1.	Technology (nm)	350	350	350	250	250	180	180	180	180	65
2.	Supply Voltage (V)	2.5	2.5	2.5	1.5	3	1.5	0.9	-	1.8	1.2
3.	Power Consumption (mW)	12.5	7	6	6	2	1.9	0.5	3.15	53.2	3.4
4.	Frequency (GHz)	1.86	4.25-6.25	2.9	1.8	315-3.85	2.28-2.59	1.86-2.01	1.9-2.2	1.8	0.75-1.5
5.	Tuning Voltage(V)	-	-	1	-	0.3-2.2	0-1.5	-	0-2.5	-	-
6.	Tuning Rang ^o (GHz)	-	-	-	-	0.7	0.31	0.15	0.3	-	0.75

VI. CONCLUSIONS

Through the comparison of power consumptions among four different topologies of LC tank VCOs, it has been observed that decreasing the supply voltage results in lower power consumption and subsequently leads to lower phase noise. This reduction in phase noise has the advantageous effect of reducing the startup energy required by the RF transmitter.

The relationship between supply voltage, power consumption, and phase noise is a significant factor in the design and optimization of LC tank VCOs. By decreasing the supply voltage, the overall power consumption of the VCO decreases, which is a desirable characteristic in many applications, particularly those with strict power constraints. Furthermore, the decrease in power consumption associated with lower supply voltage also contributes to lower phase noise. Phase noise, a measure of the random fluctuations in the phase of an oscillator's output signal, directly impacts the quality and reliability of the transmitted RF signal. By achieving lower phase noise levels through reduced power consumption, the startup energy required by the RF transmitter can be effectively reduced.

Minimizing startup energy has several benefits, including improved energy efficiency, longer battery life in portable devices, and reduced power dissipation. It allows for more efficient utilization of available power resources, resulting in optimized system performance and enhanced overall energy conservation. In summary, the study highlights the correlation between power consumption, supply voltage, and phase noise in LC tank VCOs. Lowering the supply voltage decreases power consumption, leading to lower phase noise and reduced startup energy requirements for RF transmitters. This knowledge can inform the design and optimization of LC tank VCOs, enabling the development of more energy-efficient and reliable communication systems.

REFERENCES

- [1]. V. Gazis, "A survey of standards for machine-to-machine and the internet of things", IEEE Comm. Surv. Tutor, vol.19, pp. 482–511, 2016.
- [2]. J. Lannacci, "Internet of things (IoT); internet of everything (IoE); tactile internet; 5G – A (not so evanescent) unifying vision empowered by EHMES (energy harvesting MEMS) and RF-MEMS", Sensors and Actuators A: Physical, vol. 272, pp. 187-198, 2018.
- [3]. M. Moghavvemi, "Performance Review of High-Quality-Factor, Low-Noise, and Wideband Radio-Frequency LC-VCO for Wireless Communication [Application Notes]", Microwave Magazine, vol. 12, pp. 130-146, June 2011.

- [4]. Behzad Razavi, Design of Analog CMOS Integrated Circuits, Tata McGraw hill ed., 2002.
- [5]. A. Hajimiri and T. H. Lee, "Jitter and Phase noise in ring oscillators", IEEE J. Solid State Circuits, 34(6):790-804, June 1999.
- [6]. B. Razavi, RF Microelectronics, Prentice-Hall, 1998.
- [7]. S. Levantino, C. Samori, A. Bonfanti, S.L.J. Gierkink and A.L. Lacaitai, "Frequency dependence on bias current in 5 GHz CMOS VCOs: impact on tuning range and flicker noise up conversion", IEEE J. of Solid-State Circuits, vol. 37, pp. 1003-1011, Aug. 2002.
- [8]. Mrunalini Nandanwar and Deepak Dandekar, "High Performance VCO for Low Power RF Transmitter-A Review", the National Conference on Innovative Paradigms in Engineering & Technology (NCIPET-2012), pp. 22-25, 2012.
- [9]. Mohammad Niaboli-Guilani, Dalenda Ben Issa, Abdennaceur Kachouri and Mounir Samet, "A Low Power Low Phase Noise CMOS VoltageControlled Oscillator", in 17th International Conference Electronics, Circuits, and Systems (ICECS), pp. 422 - 425, Dec. 2010.
- [10]. Nabil Boughanmi, "High Q-VCO with Low phase noise for Communications applications", in the International, Design and Test of Integrated Systems in Nanoscale Technology, Conference, pp. 370- 373, 2007.
- [11]. Han-il Lee, Tae-young Choi, Saeed Mohammadi and Linda P.B. Katehi, "An Extremely Low Power 2 GHz CMOS LC VCO for Wireless Communication Applications", The European Conference on Wireless Technology, pp. 31-34, Oct. 2005.
- [12]. Lin Jia, Kiat Seng Yeo and Manh Anh Do, "A Novel Methodology for the Design of LC Tank VCO with Low Phase Noise", in IEEE International Symposium on Circuits and Systems (ISCAS), vol. 1, pp 376-379, 23-26 May 2005.
- [13]. Ali Hajimiri and Thomas H. Lee, "Phase Noise in CMOS Differential LC Oscillators", 1998 Symposium on VLSI Circuits-Digest of Technical Papers, pp. 48-51, Jun 1998.
- [14]. R. Saeidi, N. Masoumi, F. Kalantari and M. S. Oskooei, "Analyzing of Phase Noise in CMOS LC Oscillators" in the 17th International Conference on Microelectronics (ICM), pp. 330-337, Dec. 2005.
- [15]. Mohd. Shahrul Amran, Queennie Lim Suan Imm and Albert Victor Kordeschl, "Design of a 130nm CMOS Differential Cross-coupled 5 GHz LC Oscillator", in proceeding of Asia-Pacific on applied electromagnetics, pp.20-21, December 2005.
- [16]. Zhou Mingzhu, "A low phase noise wideband VCO in 65nm RF CMOS for low power applications," in International Conference Microwave and Millimeter Wave Technology (ICMMT), pp. 1 - 4, May 2012
- [17]. Cheol-Hoe Kim, Soo-Hwan Shin, and Hyung-Joun Yoo, "A Low Phase Noise and Low Power Series Coupled Quadrature VCO Using Reconfigurable LC Tank", in International Conference Radio and Wireless Symposium, pp. 395 - 398, Jan. 2008.
- [18]. Ali Hajimiri and Thomas H. Lee, "Phase Noise in CMOS Differential LC Oscillators", 1998 Symposium on VLSI Circuits-Digest of Technical Papers, pp. 48-51, Jun 1998.
- [19]. Albert Jerng and Charles G. Sodini, "The Impact of Device Type and Sizing on Phase Noise Mechanisms", IEEE journal Of Solid State Circuits, Vol. 40, February 2005.
- [20]. Sherif Mohamed, Maurits Ortmanns, and Yiannos Manoli "Design of Current Reuse CMOS LC-VCO", IEEE, 2008.
- [21]. M. Moghavvemi, "Performance Review of High-Quality-Factor, Low-Noise, and Wideband Radio-Frequency LC-VCO for Wireless Communication [Application Notes]", Microwave Magazine, vol. 12, pp. 130-146, June 2011.
- [22]. Behzad Razavi, Design of Analog CMOS Integrated Circuits, Tata McGraw hill ed., 2002.
- [23]. A. Hajimiri and T. H. Lee, "Jitter and Phase noise in ring oscillators", IEEE J. Solid State Circuits, 34(6):790-804, June 1999.
- [24]. B. Razavi, RF Microelectronics, Prentice-Hall, 1998.
- [25]. S. Levantino, C. Samori, A. Bonfanti, S.L.J. Gierkink and A.L. Lacaitai, "Frequency dependence on bias current in 5 GHz CMOS VCOs: impact on tuning range and flicker noise up conversion", IEEE J. of Solid-State Circuits, vol. 37, pp. 1003-1011, Aug. 2002.
- [26]. Mrunalini Nandanwar and Deepak Dandekar, "High Performance VCO for Low Power RF Transmitter-A Review", the National Conference on Innovative Paradigms in Engineering & Technology (NCIPET-2012), pp. 22-25, 2012.
- [27]. Mohammad Niaboli-Guilani, Dalenda Ben Issa, Abdennaceur Kachouri and Mounir Samet, "A Low Power Low Phase Noise CMOS VoltageControlled Oscillator", in 17th International Conference Electronics, Circuits, and Systems (ICECS), pp. 422 - 425, Dec. 2010.
- [28]. Nabil Boughanmi, "High Q-VCO with Low phase noise for Communications applications", in the International, Design and Test of Integrated Systems in Nanoscale Technology, Conference, pp. 370- 373, 2007.
- [29]. Han-il Lee, Tae-young Choi, Saeed Mohammadi and Linda P.B. Katehi, "An Extremely Low Power 2 GHz CMOS LC VCO for Wireless Communication Applications", The European Conference on Wireless Technology, pp. 31-34, Oct. 2005.
- [30]. Lin Jia, Kiat Seng Yeo and Manh Anh Do, "A Novel Methodology for the Design of LC Tank VCO with Low Phase Noise", in IEEE International Symposium on Circuits and Systems (ISCAS), vol. 1, pp 376-379, 23-26 May 2005.

- [29] Ali Hajimiri and Thomas H. Lee, "Phase Noise in CMOS Differential LC Oscillators", 1998 Symposium on VLSI Circuits-Digest of Technical Papers, pp. 48-51, Jun 1998.
- [30] R. Saeidi, N. Masoumi, F. Kalantari and M. S. Oskooei, "Analyzing of Phase Noise in CMOS LC Oscillators" in the 17th International Conference on Microelectronics (ICM), pp. 330-337, Dec. 2005.
- [31] Mohd. Shahrul Amran, Queennie Lim Suan Imm and Albert Victor Kordeschl, "Design of a 130nm CMOS Differential Cross- coupled 5 GHz LC Oscillator", in proceeding of Asia-Pacific on applied electromagnetics, pp.20-21, December 2005.
- [32] Zhou Mingzhu, "A low phase noise wideband VCO in 65nm RF CMOS for low power applications," in International Conference Microwave and Millimeter Wave Technology (ICMMT), pp. 1 - 4, May 2012
- [33] Cheol-Hoe Kim, Soo-Hwan Shin, and Hyung-Joun Yoo, "A Low Phase Noise and Low Power Series Coupled Quadrature VCO Using Reconfigurable LC Tank", in International Conference Radio and Wireless Symposium, pp. 395 - 398, Jan. 2008.
- [34] Ali Hajimiri and Thomas H. Lee, "Phase Noise in CMOS Differential LC Oscillators", 1998 Symposium on VLSI Circuits-Digest of Technical Papers, pp. 48-51, Jun 1998.
- [35] Albert Jerng and Charles G. Sodini, "The Impact of Device Type and Sizing on Phase Noise Mechanisms", IEEE journal Of Solid State Circuits, Vol. 40, February 2005.
- [36] Sherif Mohamed, Maurits Ortmanns, and Yiannos Manoli "Design of Current Reuse CMOS LC-VCO", IEEE, 2008.
- [37] Iji Ayobami B, Forest Zhu, and Michael Heimlich, "Design of Low Power, Wider Tuning Range CMOS Voltage Control Oscillator for Ultra Wideband Applications", IEEE International Conference on IC Design & Technology (ICICDT),
- [38] M. A. Nandanwar, M. A. Gaikwad and D. Dandekar "Low Power Low Phase Noise CMOS LC VCO – A Review", International Journal of Applied Information Systems (IJ AIS) – ISSN : 2249-0868