

I Draw Hand Writing Robot

Bhairavi P.Chamate, Komal Meshram, Nimisha Ghatole, Raviksha Dhomne, Prof. Swati Dhabarde

Department of Computer Science and Engineering,
Priyadarshini College of Engineering,
Nagpur

Email: bhairavichamate252@gmail.com, meshram32@gmail.com, ghatolenimisha2002@gmail.com,
shubhravi1110.dhomne@gmail.com

Abstract- In industrial use, most of the chunks are obtained from accomplish to make it understandable, In this system, we have understood and formed I draw handwritingrobot The main idea is to develop an I- draw handwriting robot that can be taken to any place with comfort. So the controller. This robot can draw both parallel and upstanding. Its single design structures a writing head that spreads beyond the machine, making it possible to draw on objects greater than the machine itself. The major benefit of the machine is that it can be located over the hardcover because the core XY extends the design of the machine.

Keywords- Arduino Uno, Servo Motor.

I. INTRODUCTION

A Plotter is a superior type of printer that uses a pen to draw images on solid surfaces. CNC Machining is a method used in the engineering sector that involves the use of computers to control machine tools. A computer program is modified for an object and the machines are programmed with CNC machine language called G-code that fundamentally wheels all features like feed rate, organization, position and speeds. With CNC machining, the computer can control meticulous location and velocity are provided by using a microcontroller in the form of code or text. In an automatic sketcher machine, the microcontroller is used which is capable of processing logical instructions interfaced with it. The logical commands or image is then changed into a machine language. This automatic sketcher machine is a 2D controller machine that uses a pen to draw text or draw images on given solid surfaces. It can be used for the purposes such as PCB Design, logo design, etc. This project is based on a CNC plotter machine.

With the growing demand for the use of CNC plotters in academies and laboratories, a low-priced and less complex design is a complete need. The parts used for the plotter in our project are with no trouble available at a very low price and spare parts are also used. The creation is very simple and robust. A pen touches the surface & prints the pixel for logic 1 and kicks up in the air for logic zero & actuator changes its position for the execution of the next command Presented plotter is a two-dimensional 2D sketcher machine.

II. LITERATURE SURVEY

Development Controller for 2 Axis Mechanism Machines [1]: Basically a two-axis machine does not

have more than 10 components in the machine to make a movement. Axes are interpreted by the path of signal control by the servo motor.

The number of axis of a machine is determined by its machining capabilities, the number of axes in a movement machine depends on the application example in the automotive industry order to produce a cylindrical piston chamber for a car engine requires more angle for the machine such that it needs a 5 axis machine to meet the requirement for the machining process. In order to understand a two-axis mechanism machine, there is a need to determine which components had to utilize such that it can perform smoothly and efficiently. The components in 2 axis machine are:- Linear slides, Ball bearing slides, Dovetail slides, Machine slides, Roller slides, Roller tables XYtable.

Computer Numerical Control Programming Basics

[2]: Early machine tools were designed such that the operator was standing in front of the machine while operating the controls. This design is no longer necessary since in CNC the operator no longer controls the machine tool movements. On conventional machine tools, only about 20 percent of the time was spent on removing material. With the addition of electronic controls, actual time spent on removing metal has increased to 80 percent and even higher.

It has also reduced the amount of time required to bring the cutting tool into each machining position. Two types of programming modes are present in CNC, the incremental system and the absolute system, are used for CNC. Both systems have applications in CNC programming, and no system is either right or wrong all the time. Most controls on machine tools of today are capable of handling either incremental or absolute programming.

CNC programming sprays into two separate categories the difference between the two categories are very separate. Now, still, most control units are able to handle both point-to-point and continuous path machining. Knowledge of both programming methods is needed to understand what applications in each have CNC. G-code is also explained in this paper.

Model and Fabrication of CNC Plotter Machine [3]:

The paper proposed a concept of a low-cost mini CNC plotter machine, which is easily controlled with a computer and can be suddenly stopped and paused by clicking an action on the computer. By using this Difficult and Complex Designs can be made on paper. This is a small machine which is easily Transportable and Assembled everywhere on Requirement of it. The cot Size of this machine is 50X50mm. Stepper Motor will be run on in this criteria of cot size. G-codes are etymological to give the knowledge to the machine to move right, left or up and down.

Implementation of Low-Cost CNC Plotter Using Arduino [4]:

This paper discusses on implementation of a project, about building a mechanical prototype of a CNC plotter machine that is able to draw a PCB layout of 20cm by 20cm (or any image/text) on a given solid surface. It consumes low power and works with high accuracy due to the designed precise control of stepper motors. This is a low-cost project as compared to other CNC products. It is made with easily obtainable apparatuses and spare parts. It is intended for private industrial and small-scale applications in educational institutes.

The machine is intended with a very simple creation scheme and can be carried anywhere without much effort. The algorithm used is simple. The pen can be replaced by a pinhead or laser head or any other tool for different tenacities of use. The software that has been used is open-source and user-friendly. It is designed for private manufacturing and small-scale applications in educational institutes.

The machine is intended with a very simple structure scheme and can be approved anywhere without remote effort. The algorithm used is simple. The pen can be swapped with a pinhead or laser head or any other tool for different resolutions of use. The software that has been used is open-source and user-friendly. The pen of the machine can be swapped by a laser to make it work like a laser inscription or critical machine. A design machine can be used on wood. The pen can also be replaced with a powerful tool such that it can be used for both grinding and drilling purposes.

Development Controller for 2 Axis Mechanism Machines [1]:

Basically a two-axis machine does not have more than 10 components in the machine to make a movement. Axes are interpreted by the path of signal

control by the servo motor. The number of axis of a machine is determined by its machining capabilities, the number of axes in a movement machine depends on the application example in the automotive industry order to produce a cylindrical piston chamber for a car engine requires more angle for the machine such that it needs a 5 axis machine to meet the requirement for the machining process. In order to understand a two-axis mechanism machine, there is a need to determine which components had to utilize such that it can perform smoothly and efficiently. The components in 2 axis machine are: -Linear slides, Ball bearing slides, Dovetail slides, Machine slides, Roller slides, Roller tables XY table.

Computer Numerical Control Programming Basics [2]:

Early machine tools were designed such that the operator was standing in front of the machine while operating the controls. This design is no longer necessary since in CNC the operator no longer controls the machine tool movements. On conventional machine tools, only about 20 percent of the time was spent on removing material. With the addition of electronic controls, actual time spent on removing metal has increased to 80 percent and even higher.

It has also reduced the amount of time required to bring the cutting tool into each machining position. Two types of programming modes are present in CNC, the incremental system and the absolute system, are used for CNC. Both systems have applications in CNC programming, and no system is either right or wrong all the time. Most controls on machine tools of today are capable of handling either incremental or absolute programming.

CNC programming sprays into two separate categories the difference between the two categories are very separate. Now, still, most control units are able to handle both point-to-point and continuous path machining. Knowledge of both programming methods is needed to understand what applications in each have CNC. G-code is also explained in this paper.

Model and Fabrication of CNC Plotter Machine [3]:

The paper proposed a concept of a low-cost mini CNC plotter machine, which is easily controlled with a computer and can be suddenly stopped and paused by clicking an action on the computer. By using this Difficult and Complex Designs can be made on paper. This is a small machine which is easily Transportable and Assembled everywhere on Requirement of it. The cot Size of this machine is 50X50mm. Stepper Motor will be run on in this criteria of cot size. G-codes are etymological to give the knowledge to the machine to move right, left or up and down.

Implementation of Low-Cost CNC Plotter Using Arduino [4]:

This paper discusses on implementation of a

project, about building a mechanical prototype of a CNC plotter machine that is able to draw a PCB layout of 20cm by 20cm (or any image/text) on a given solid surface. It consumes low power and works with high accuracy due to the designed precise control of stepper motors. This is a low-cost project as compared to other CNC products. It is made with easily obtainable apparatuses and spare parts.

It is intended for private industrial and small-scale applications in educational institutes. The machine is intended with a very simple creation scheme and can be carried anywhere without much effort. The algorithm used is simple. The pen can be replaced by a pinhead or laser head or any other tool for different tenacities of use. The software that has been used is open- source and user-friendly. It is designed for private manufacturing and small-scale applications in educational institutes. The machine is intended with a very simple structure scheme and can be approved anywhere without remote effort. The algorithm used is simple.

The pen can be swapped with a pinhead or laser head or any other tool for different resolutions of use. The software that has been used is open-source and user-friendly. The pen of the machine can be swapped by a laser to make it work like a laser inscription or critical machine. A design machine can be used on wood. The pen can also be replaced with a powerful tool such that it can be used for both grinding and drilling purpose.

III. PROBLEM STATEMENT

Nowadays some of the CNC XY plotters are being made all over the world using the CD drive for the digital scanner mechanism which provides the required gesture along the X-direction & Y-direction. So, this industrial process is not suitable for the mass production of plotters. Again, the value of the plotters in the present market is fairly high too. So, in order to solve these limitations, we intended a CNC XY Plotter suitable for mass production which is economical as well. Also, security is not provided in the conservative plotter.

IV. BLOCK DIAGRAM

The block diagram of the pen plotter is shown in figure 1. In the block diagram, the microcontroller Arduino uno (ATmega328) is used for controlling purposes and giving direction to the stepper motor to draw the image and also provide the pen up-down decision to the servo motor. The CNC driver circuit is used to provide sufficient voltage to the stepper motor.

1. Servo motor:

A servo motor is an electromechanical device that converts electrical energy into mechanical energy. Servo motors can be powered by current sources. Microcontrollers command these motors through the

motor-controller circuit to take the necessary action. A servo motor mainly consists of a DC motor, a waste system, a position sensor which is mostly a potentiometer, and control electronics. The DC motor is connected with a gear mechanism that provides feedback to a position sensor which is mostly a potentiometer.

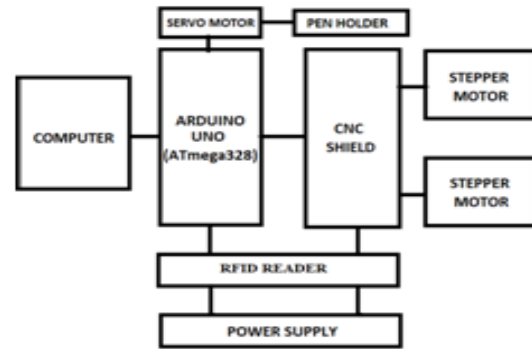

Fig 1. Block diagram.



Fig 2. Servo motor.

2. Stepper motor:

Stepper motors can be observed as plug-in motors without commutators. Naturally, all winds in the motor are part of the stator, and the rotor is either a permanent lodestone or, in the instance of variable disinclination motors, a toothed block of some magnetically lax material. In another word, the stepper motor is a brushless DC Motor that works based on the spin in an equal step of a full rotation.

3. Microcontroller (Arduino uno- ATmega328):

Arduino is an open-source electronics prototyping display place based on stretchy, easy-to-use hardware and software. This microcontroller is very powerful and it can perform many tasks including robot control. The onboard chipset uses an ATMEL microprocessor and can easily be programmed by using Arduino programming language and Arduino development environment.

Commercially there are many types of Arduino in the market such as Arduino Mega, Arduino Leonardo, Arduino Uno, Arduino Nano, etc. Those entire microcontrollers had different features and differences in size which suit different projects. For instance, Arduino Uno is suitable to build a mini robot that only has a few applications due to its small size Besides, Arduino also comes with Arduino shields that are capable to install on the Arduino main board. Those shields are equipped with an extra component like an Ethernet port, Wi-Fi card, and

motor driver IC. To drive a motor by using an Arduino microcontroller, it is advisable to use Motor Shield that can drive the DC motor, Stepper motor, or an RC servo motor.

Users can easily change the speed of the motor by connecting the motor with the motor driver to the PWM pin on the Arduino main board. In this project, Arduino UNO is chosen as the main microcontroller. This is because the onboard pins that are allocated for the user are more than enough to operate two stepper motors and one servo which make this XY plotter function.

4. Advantages:

- Plotters can print with implausible speed and consistency.
- It can work with nearly 100% accuracy.
- They work with massive speed which does not decay the design and excellence of output produced by contemporary plotters.
- The plotters are used by establishments for quality printouts.
- A big number of printouts can be produced in a smaller amount of time.
- The Plotters are used to print direction graphic images and pictures of comparatively big sizes compared to printers.
- The Plotter is used in drawing, diagrams, building maps, engineering drawings, 3d printing, etc.
- Modern plotters can be used as a component of a computer system or a separate device.
- The Plotters can work with definite software like Adobe Illustrator, Corel, Flexi, and CAD.
- Plotters are very efficient.



Fig 3. Arduino.

V. FUTURE SCOPE

Same Instrument can be used for 3D printing by adding a Z-axis in the machine. Drilling, PCB making, and Laser linocut can be done with this model by altering the pen holder module. The system can be useful for industrial purposes. It can be used to draw and print on hefty sheets to obtain results in high resolution with maintaining and preserving DPI.

REFERENCES

- [1] D. Moreton and R. Durnford, "Three- dimensional tool compensation for a threeaxis turning centre," The International Journal of Advanced Manufacturing Technology, vol. 15, pp. 649-654, 1999.
- [2] R.-S. Lin, "Real-time surface interpolator for 3-D parametric surface machining on 3-axis machine tools," International Journal of Machine Tools and Manufacture, vol. 40, pp. 1513-1526, 2000.
- [3] Publisher McGraw-Hill Education -Europe Imprint TAB Books Inc. Publication City/Country New York, United States Kelly and P. Hood, Daniel, "Build Your Own CNC Machine – Text book Copyright 2009 ISBN-13,publication: 978-1-4302-2489-1 ISBN-13 (electronic): 978-1-4302-2490-7.
- [4] Paulo Augusto Sherring da Rocha Junior, "Prototype CNC Machine Design" <https://www.researchgate.net/publication/241180827>, Article • November 2010, DOI: 10.1109/INDUSCON.2010.5740068.
- [5] Alan Over, "CNC Machining Handbook", Programming, and Implementation– Publication date 12 Nov 2010.
- [6] Muhammaad Hayyul Bin Sohaimi Faculty of Manufacturing Engineering "Development Controller for 2 Axis Mechanism Machine" by University Malaysia Pahang, 2012.
- [7] D'Ausilio, "Arduino: A low-cost multipurpose lab equipment," Behavior research methods, vol. 44, S.Di Prima, "Automated single ring infiltrometer with low-cost microcontroller circuit," Computers and Electronics in Agriculture, vol. 118, pp. 390-395, 2015.
- [8] J Kajal, Kranti R Madekar, "Automatic mini CNC machine for PCB drawing and drilling" in International Research Journal of Engineering and Technology (IRJET), Volume: 03 Issue: 02 | Feb-2016. | Mar 2019, eISSN:6. 2395-0056, p-ISSN: 2395-0072, www.irjet.net.
- [9] Udit Pandey, Swapnil Raj Sharma, "Model and Fabrication of CNC Plotter Machine" in International Journal of Advanced Research in Computer and Communication Engineering, ISO3297:2007 Certified Vol. 6, Issue 6, June 2017
- [10] Roshani Sahare, Shivam Londhe, "Implementation of Low Cost CNC Plotter Using Arduino" in International Journal for Research in Applied Science & Engineering Technology (IJRASET) , April 2018.