

# Grid to Vehicle and Vehicle to Grid Energy Transfer Using Three -Phase Bidirectional AC-DC Converter

Lokesh Kumar Sharma, Bhanu Pratap Soni, Ankit Kumar Sharma

Department of Power System,  
University of Engineering & Management,  
Jaipur

Email-lokesh.sharma694@gmail.com, bhanu.soni@fnu.ac.fj, ankit.krishnaa@gmail.com

**Abstract-** Chargers must be efficient so that electric cars (EVs) and plug-in hybrid electric vehicles (PHEVs) can be charged at the right rate as they become more popular. It would also make charging more expensive, because more people would use the traditional power grid. It's because of this that more people are going to use local, renewable sources of energy instead. PV panels, which convert sunlight into electricity, can be added to the traditional power grid. As well wind converter designed to convert the energy of wind movement into mechanical power this could make the traditional grid more efficient. A place to recharge in this thesis, PV and the grid are used to power EV loads. However, Because of the PV's intermittent nature, which is very dependent on where you live and the weather, it is well-known that it isn't very stable Conditions. To make up for the PV's inconsistency, a battery storage system is used. An electric car charging station powered by solar panels and wind that are part of a system that is connected to the grid. Most of the time, hybrid charging stations are supposed to be, efficient, and safe to use. The needs of electric vehicles in a variety of situations by giving them more options. This thesis talks about how to be more efficient at the top. PV power generation on site is planned and implemented to meet the needs of the project. Using BSS, electric cars can have a more varied load, which lessens the strain on the grid. This method works. Improves overall performance, reliability, and cost by a lot. Efficiency in converting power in both directions interleaved buck-boost converters are added to BSS to make sure it works. By using BSS, conversion losses can be kept to a minimum. This structure could help to reduce the waves that are already there. Electricity will be better if you improve its quality to get the most out of a PV system while keeping it as environmentally friendly as possible. MPPT and an interleaved boost converter are used when the weather isn't always clear. This way, the output stays the same. PV power will always be available. In the same way, to deal with the changing power needs of car chargers, Converters should be put together in a way that meets the needs of electric cars while also keeping the balance between the levels of power that can be generated.

**Keywords-** V2G and G2V three -phase inverter, MPPT, BSS, solar, DFIG.

## I. INTRODUCTION

Renewable energy is power derived from natural possessions, such as solar, wind, waves, or geothermal energy. These resources are renewable and can be recycled naturally. Therefore, compared to the depletion of traditional fossil fuels [1], these sources of information are considered inexhaustible. The global power crunch provides a new impetus for the development or maturity of clean or renewable energy. [2].

In addition to the decline in fossil fuel transportation worldwide, another major reason fossil fuels do not work is the pollution associated with burning fossil fuels. In contrast, it is well known that compared to traditional energy sources, renewable energy sources are cleaner, or energy produced has no adverse effects on pollution. If you're looking for a renewable source of energy, look no further than wind power. Over the past few decades, it has

become the most stable and advanced option. Most of the progress in wind power systems is due to the growing public interest in renewable energy, government support, and improvements in the power electronics industry, which is the backbone of these systems. Because of this, the amount of wind power in the world's total installed power capacity has gone up.

The most common type of WECS for multi-megawatt wind farms is one with variable-speed, variable-pitch wind turbines that are equipped with DFIG. Because only partial size-rated power converters are needed for full control of the machine, the cost is kept low and the mechanical stress is kept to a minimum. This makes the DFIG-based WECS a very attractive option.

Because of these technical and financial benefits, the wind power industry has moved quickly toward making this wind turbine available to the public. Because of things like

good wind conditions, noise pollution, size, and how they change the view, these wind turbines are often set up in remote places or offshore. In these areas, it is common to have weak power networks with low short circuit ratios and low voltage.

As a result, it is significant to evaluate its dynamic performance and effects on the interconnected power network in terms of reactive power capability and voltage management if it is to be used more in the modern power system. The voltage of this bus in the grid of electricity is a local variable. Traditional power plants located elsewhere on the system make it hard, if not impossible, to control the voltage at the remote node. Because of this, a local source of reactive power is needed. The fast growth of power electronics technology has made it possible for power systems to use FACTS devices with a fast response time. The goal of this research is to improve the dynamic and steady-state stability of the wind turbine system and the associated weak power system by increasing the reactive power capability and voltage controllability of the DFIG wind turbine system through the STATCOM at the PCC.

When used on a transmission line, series compensation not only makes it better at moving electricity, but it also helps keep the voltage steady. Also, it is important to use DFIG-based WECS for off-grid applications to bring electricity to places that are far from the main power grid. This way of running a business uses WECS built on the DFIG architecture without any outside control. When supplying part of an isolated load, a grid-connected DFIG system must be able to work on its own in case a broken transmission line or permanent short circuit in the grid cuts off the main supply. So, the power grid becomes more reliable. So, the goal of this thesis is to help us learn more about the DFIG-based WECS and how it works with the STATCOM and the series compensated line.

## II. RELATED WORK

**Md Aktarujjaman et al. (2020)** Inverter-interfaced renewable energy sources are likely to replace fossil fuel-powered classic synchronous generators from the existing power system in the next years. Wind turbines based on doubly fed induction generators are predicted to be among these renewable energy sources (DFIG). Since wind power comes and goes and there is no system inertia, this will change the way the grid works in a big way. This article used professional simulation software called PSS/E to show how adding DFIG-based wind turbines to the grid could change the frequency and voltage of the network.

With a model of the electric grid system that includes hydro, gas, and wind generating, the modelling studies are done under different voltage and frequency disturbances or contingencies. In the testing that was done in simulation, different DFIG-based wind turbines were used. As a direct

result of this investigation and analysis, the system frequency and the effects of many faults on the system voltage are looked at in great detail. This study also looks at the grid code requirements for DFIG-based wind generators in electrical grids where there are a lot of DFIG-based turbines. Simulations show that DFIG-based wind turbines can help keep the frequency and voltage of the system stable during power outages and other emergencies.

**Subinay Vajpayee et al. (2020)** discusses the use of a PLL control technique in a doubly fed induction generator to improve the management of imbalance grid voltage in real time grid synchronisation. DFIG is an abbreviation for double fed induction generator (DFIG). The impact of uneven voltage on traditional PLLs based on dq conversion is demonstrated in this work. All of the modelling and simulation were done in PSCAD.

Even though the grid voltage is balanced, the unbalanced positive sequence component significantly improves PLL stability. Because it is rapid and stable, the proposed technique may be employed in DFIG's wind power system even when the main grid is down, making it perfect for usage in wind turbines. As a result, the system was built to deal with both ordinary and unusual circumstances. The addition of a PLL considerably improved the system's stability.

## III. PROPOSED SYSTEM

The grid-interfaced DFIG-based WECS is proposed for power smoothing in this system. For rotor position estimation, the rotor position computation method is utilised [24]. The work's uniqueness comes from GSC's control (Grid Side Converter). The control algorithm for providing regulated electricity to the grid has therefore been explicitly proven by the authors.

Another essential feature of DFIG-based WECS for power smoothing is BESS selection. When comparing the standard DFIG with the suggested DFIG, the differences in powers with increasing wind speeds are displayed. The system's functioning has been experimentally confirmed for controlling DFIG power under fluctuating wind speed circumstances.

Figure 1 shows a schematic representation of the proposed grid interfaced DFIG based WECS. The BESS is linked to the DC connection of two VSCs that are connected back-to-back. The stator is directly linked to the grid in this case. In a voltage-oriented reference frame, RSC is regulated. PLL is used to align the d-axis of the synchronously rotating reference frame with the voltage axis (Phase Locked Loop).

The rotor position computation technique is utilised to estimate the location here. The GSC is set up such that the

regulated electricity is supplied into the grid. When the generated power exceeds the regulated power, the leftover energy is stored in the BESS. If the amount of energy generated is less than the regulated amount, the BESS feeds the leftover energy to the grid. Figure 2 depicts the control algorithms.

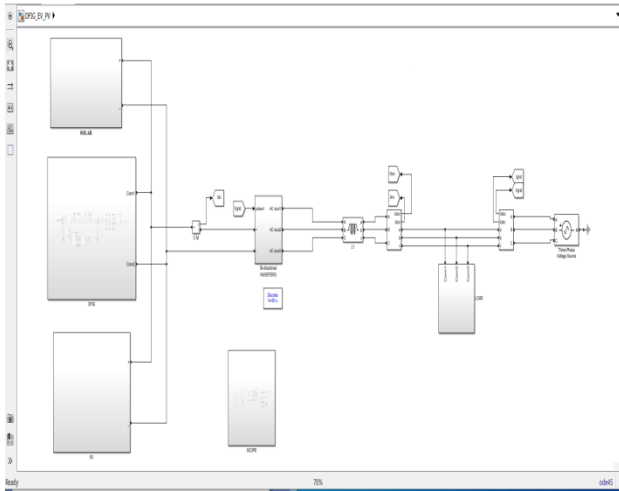

Fig 1. Proposed Simulink model.

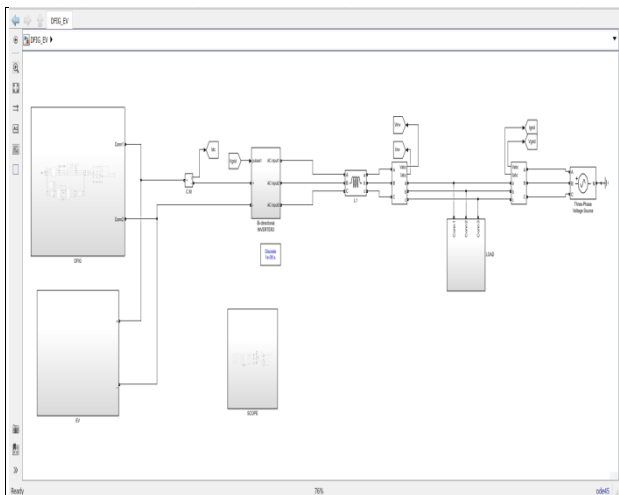

Fig 2. Proposed Simulink Model without Solar Panel.

The larger the battery, the more reliable it is, but it also raises the initial outlay. However, the battery's low rating has an impact on its dependability [18]. As a result, suitable BESS design is required for the proposed WECS to function properly. The BESS's storage capacity is determined by the site's estimated wind profile. The total energy stored in the battery determines the BESS's rating.

#### Modules with Solar Panel

- Solar panel
- Battery
- PID Controller
- SVM Subsystem
- DFIG
- Bidirectional converter

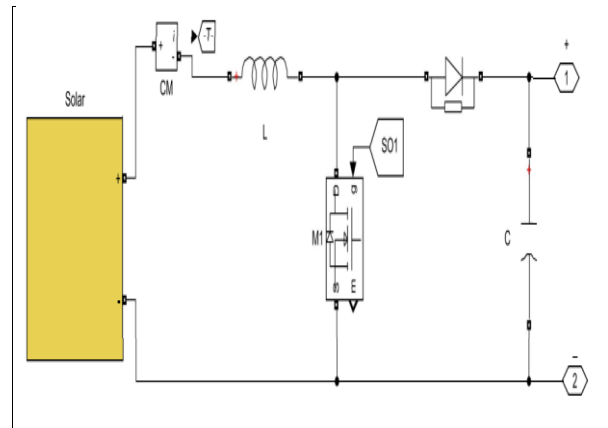

Fig 3. Solar Cell Structure.

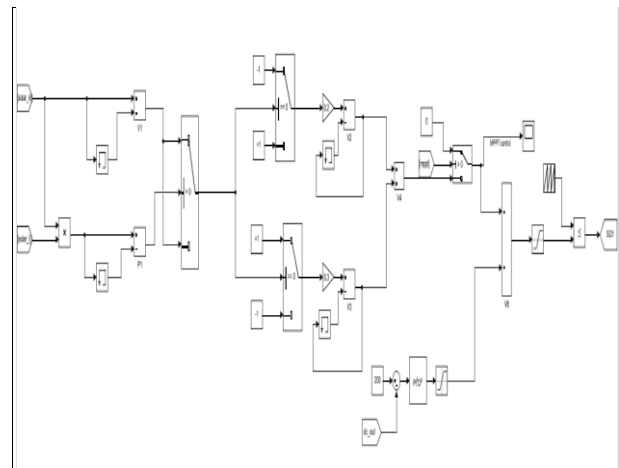

Fig 4. MPPT Control.

SOLAR - This building block is a model of a solar cell. It is made up of a current source, two exponential diodes, a parallel resistor,  $R_p$ , and a series resistor,  $R_s$ . A solar cell is also represented by this block as a parallel combination of a parallel resistor,  $R_p$ .

Here's how to figure out the output current I:

$$I = I_{ph} - I_s \cdot (e^{(V+I \cdot R_s)/(N \cdot V_t)} - 1) - I_{s2} \cdot (e^{(V+I \cdot R_s)/(N2 \cdot V_t)} - 1) - (V+I \cdot R_s)/R_p$$

Both the rotor and the stator windings of a "doubly fed" electric machine get their power from the same power source. This gives them alternating currents. Most of the induction machines used in industry is double-fed wound-rotor machines. Double-fed induction devices are used a lot in the modern world of wind energy generation.

where  $I_s$  and  $I_{s2}$  are the diode saturation currents,  $V_t$  is the thermal voltage,  $N$  and  $N2$  are the quality factors (diode emission coefficients), and  $I_{ph}$  is the current made by the sun. The mask makes it possible to specify models with lower levels of complexity. The quality factor for amorphous cells can be anywhere from 1 to 2, but it is usually between those two numbers. The value that goes

into the PS is the irradiance (the amount of light) in W/m<sup>2</sup> that hits the cell. The formula  $I_r = I_{ph0}/I_{r0}$  can be used to figure out the solar-generated current  $I_{ph}$ , where  $I_{ph0}$  is the measured solar-generated current for the irradiance  $I_{r0}$ . Battery Simulink Model -Implements a generic battery model for most popular battery types. Temperature and aging (due to cycling) effects can be specified for Lithium-Ion battery type.

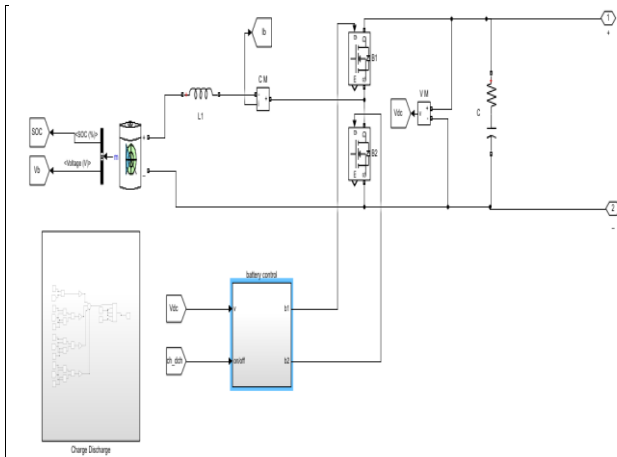

Fig 5. Battery Simulink Model.

Different soc charging condition performed in the simulation

- If soc less than 25 , it will charge
- If soc between 25 to 50, it will charge
- If soc between 50 to 90, it will charge
- If soc between 90to 100, it will discharge
- Bidirectional DC TO DC Converter

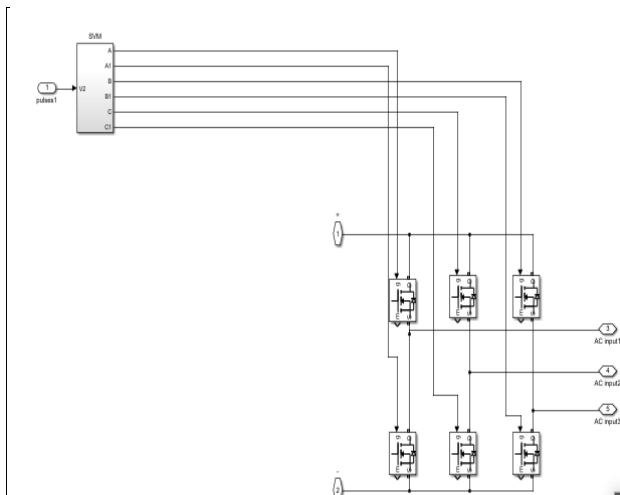

Fig 6. Bidirectional DC TO DC Converter.

PID-This block implements continuous- and discrete-time PID control algorithms with setpoint weighting and includes advanced features such as anti-windup, external reset, and signal tracking. You can tune the PID gains automatically using the "Tune..." button (requires Simulink Control Design).

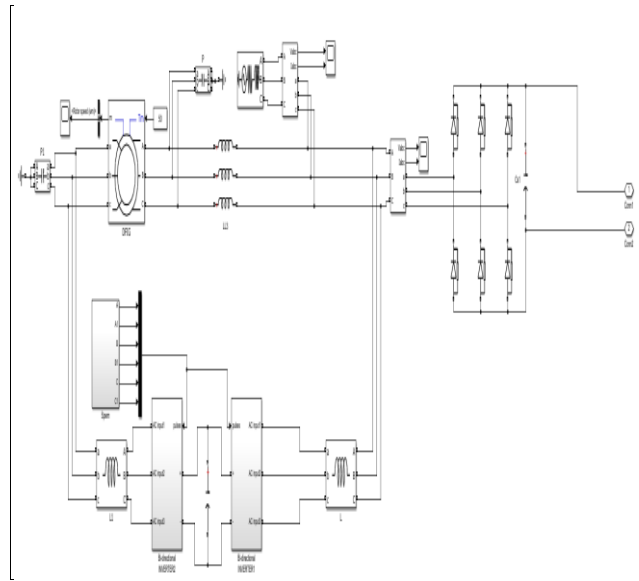

Fig 7. DFIG System.

The grid-interfaced DFIG-based WECS is proposed for power smoothing in this paper. For rotor position estimation, the rotor position computation method is utilised [24]. The work's uniqueness comes from GSC's control (Grid Side Converter). The control algorithm for providing regulated electricity to the grid has therefore been explicitly proven by the authors.

Another essential feature of DFIG-based WECS for power smoothing is BESS selection. When comparing the standard DFIG with the suggested DFIG, the differences in powers with increasing wind speeds are displayed. The system's functioning has been experimentally confirmed for controlling DFIG power under fluctuating wind speed circumstances.

WECS. The BESS is linked to the DC connection of two VSCs that are connected back to back. The stator is directly linked to the grid in this case. In a voltage-oriented reference frame, RSC is regulated. EPLL is used to align the d-axis of the synchronously rotating reference frame with the voltage axis (Enhanced Phase Locked Loop). The rotor position computation technique is utilized to estimate the location here. The GSC is set up such that the regulated electricity is supplied into the grid. When the generated power exceeds the regulated power, the leftover energy is stored in the BESS. If the amount of energy generated is less than the regulated amount, the BESS feeds the leftover energy to the grid. Figure 4.12 depicts the control algorithms.

Implements a three-phase asynchronous machine, which can be either a wound rotor, a squirrel cage, or a double squirrel cage, and can be modelled in a dq reference frame chosen by the user (rotor, stator, or synchronous). The stator and rotor's windings are connected to a neutral point inside the machine by a wye.

#### IV. SIMULATION RESULT

The Matlab/Simulink environment is used to make a detailed electromechanical model of a DFIG-based wind turbine that is connected to the power grid, as well as a wind turbine system that runs on its own and stores energy in batteries. This control mechanism and how the whole wind turbine system works when it is in a steady state are both explained in detail. The ability of the DFIG to provide reactive power in a constant state.

##### 1. Simulation Result With Solar:

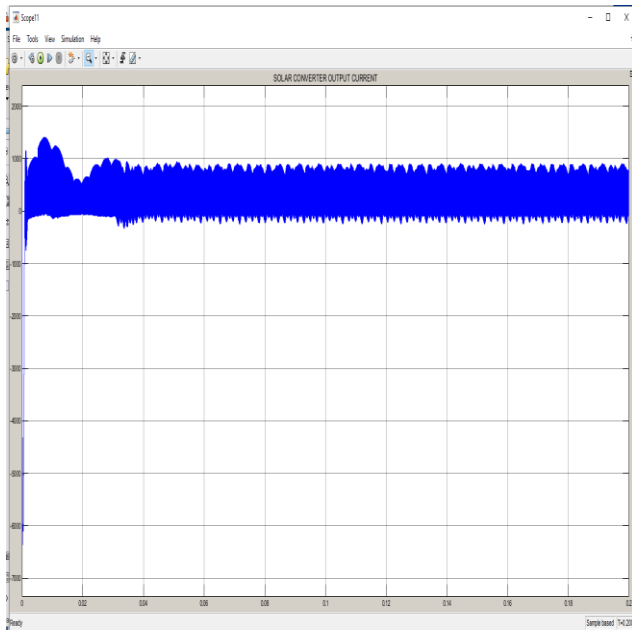

Fig 8. Solar Output Current.

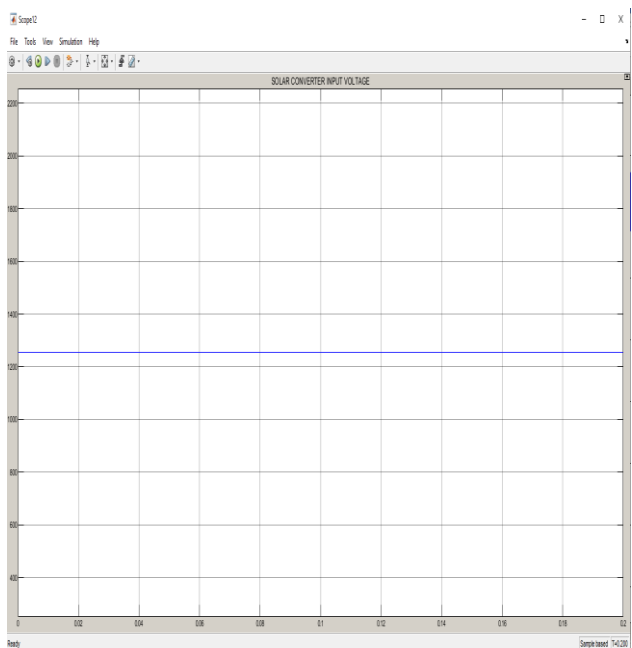

Fig 9. Solar converter input current.

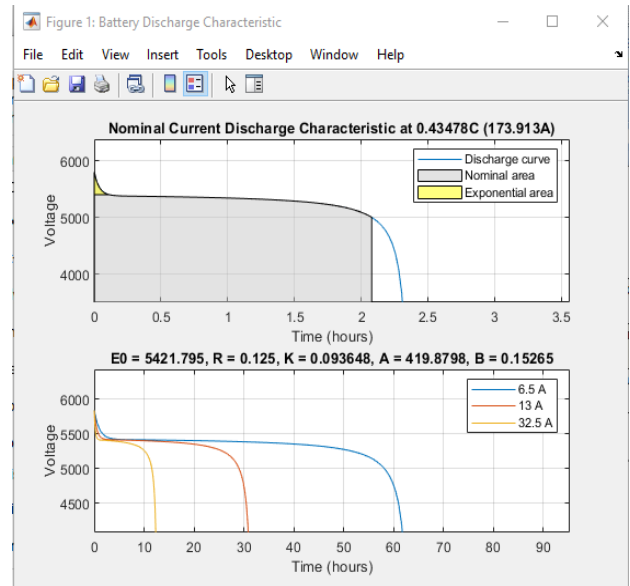

Fig 10. Battery discharging characteristics.

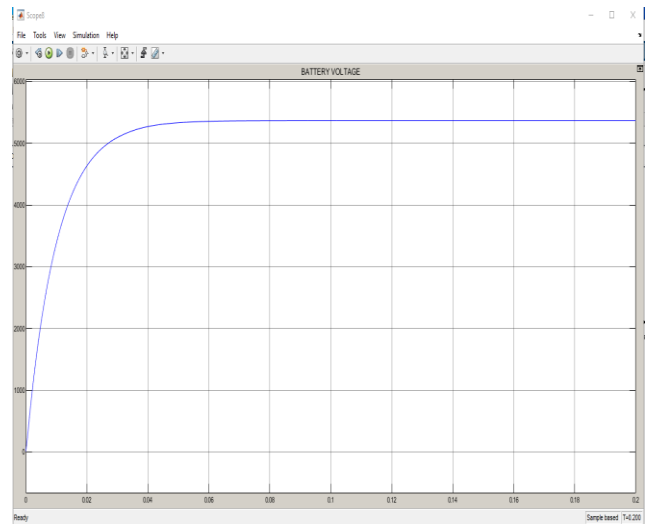

Fig 11. Battery voltage.

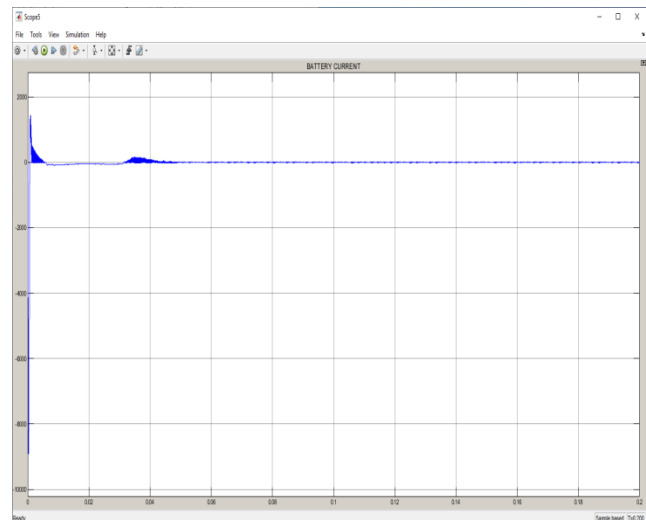

Fig 12. Battery current.

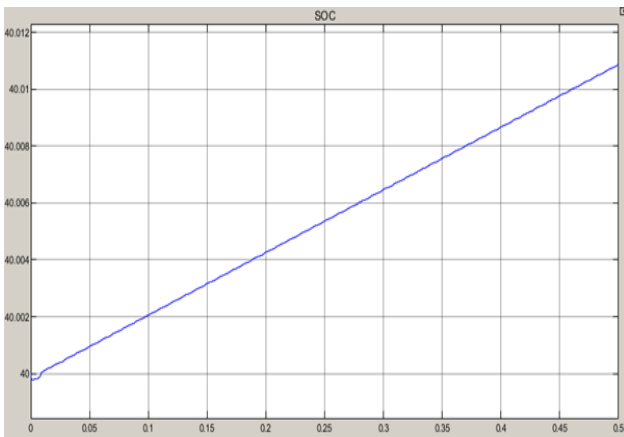

Fig 13. SOC charging at 40%

In the simulation 4 SOC condition check to check the SOC of the battery in the first case If soc between 0 to 25% , it will charge showing in fig 12.

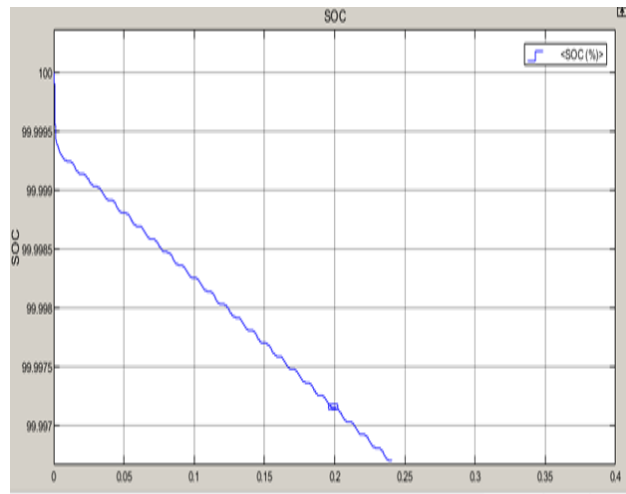

Fig 16. SOC discharging at 100%

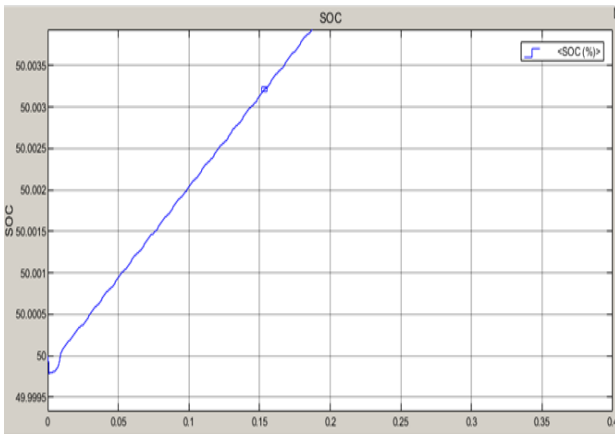

Fig 14. SOC charging at 50%

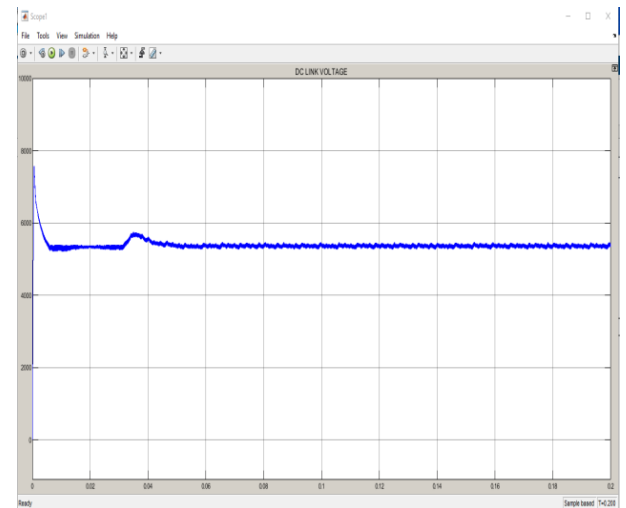

Fig 17. DC link voltage.

In the third case If soc between 50% to 90%, it will charge showing in fig 13.

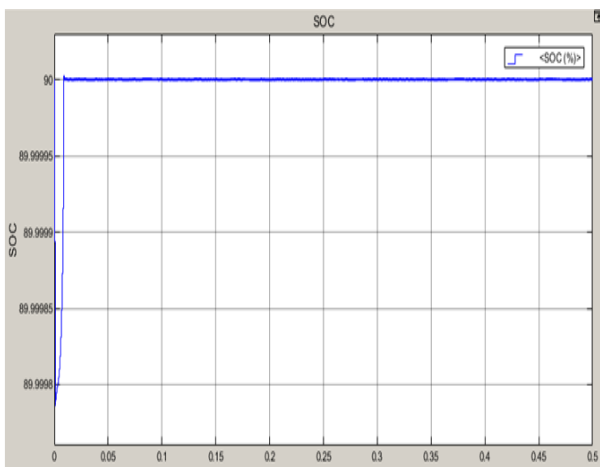

Fig 15. SOC charging at 90%

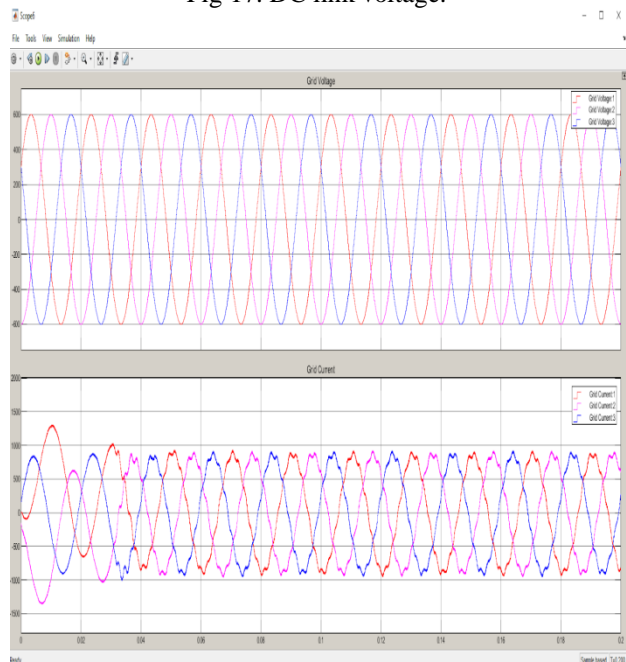

Fig 18. Grid voltage and current.

In the third case If soc between 50% to 90%, it will charge showing in fig 14.

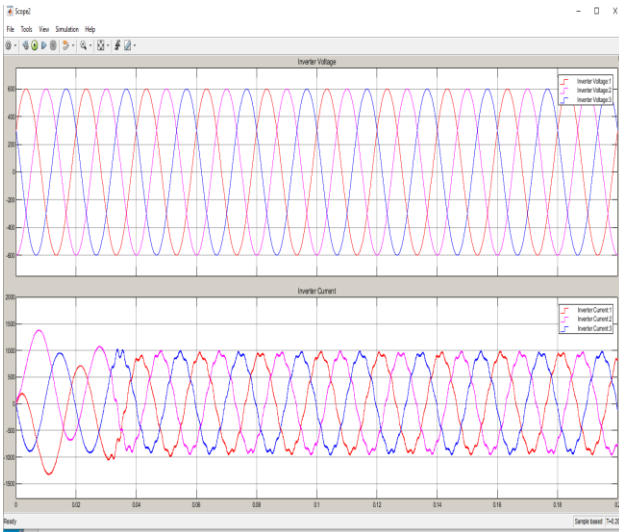

Fig 19. Inverter voltage and current.

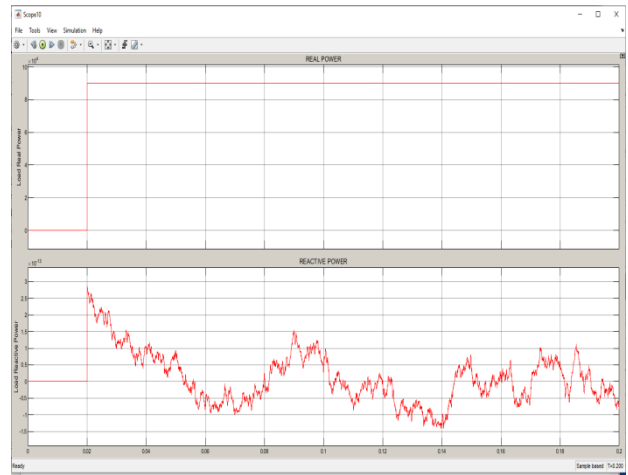

Fig 22. Load real power and reactive power.

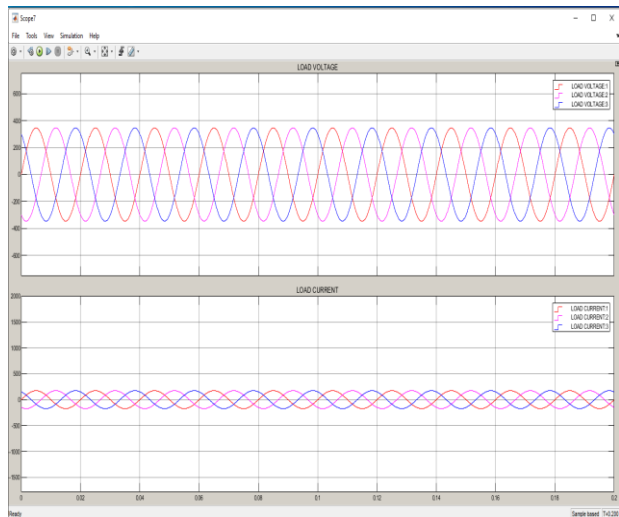

Fig 20. Load voltage and current.

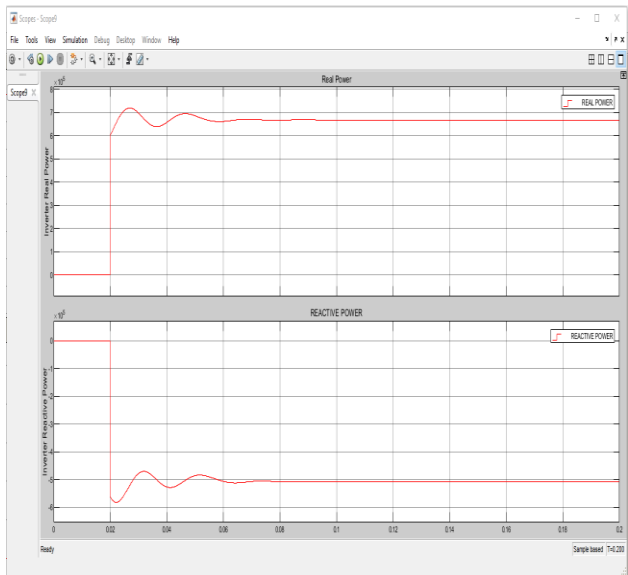

Fig 23. Inverter real power and reactive power.

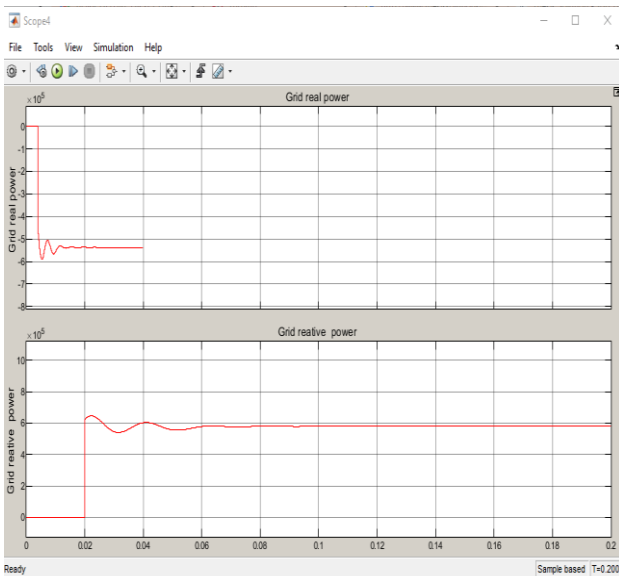

Fig 21. Grid real power and reactive power.

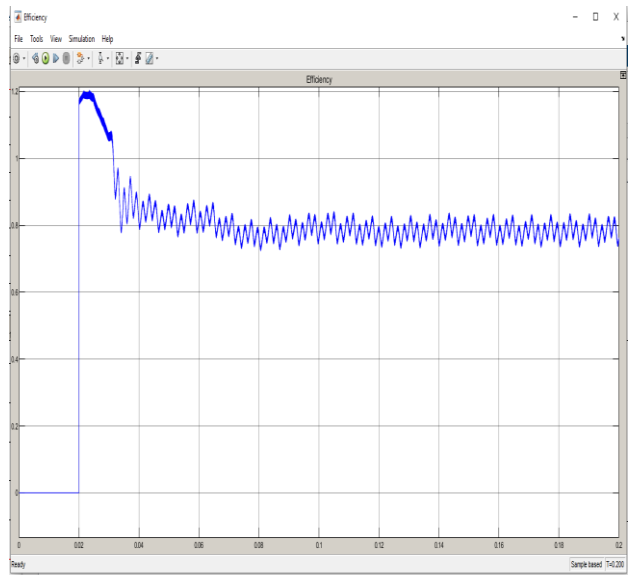

Fig 24. System efficiency.

## 2. Simulation Result Without Solar:

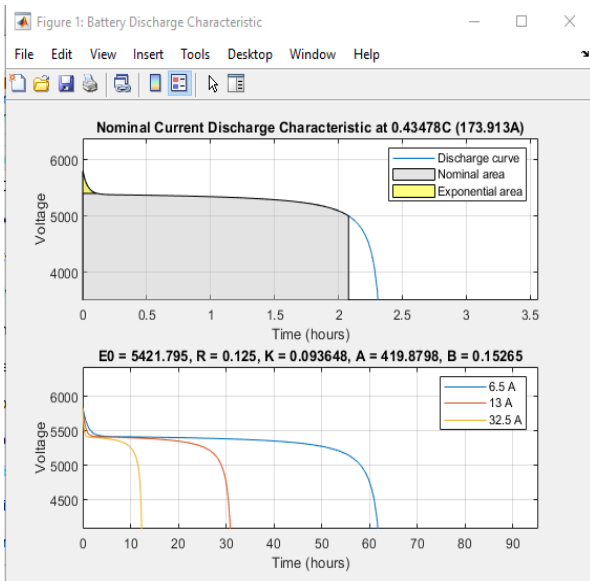

Fig 25. Battery discharging characteristics.

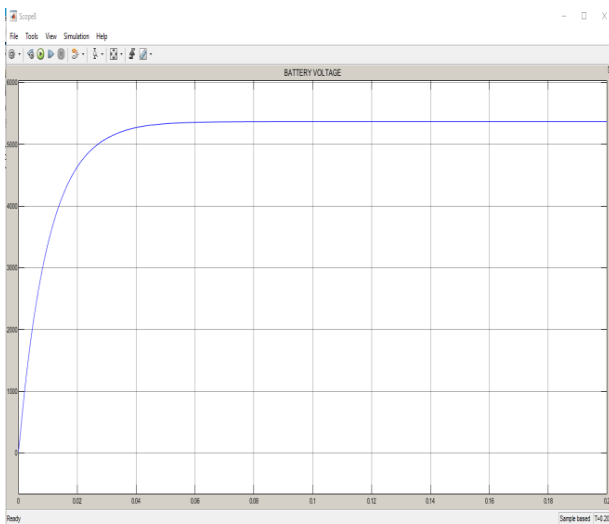

Fig 26. Battery voltage.

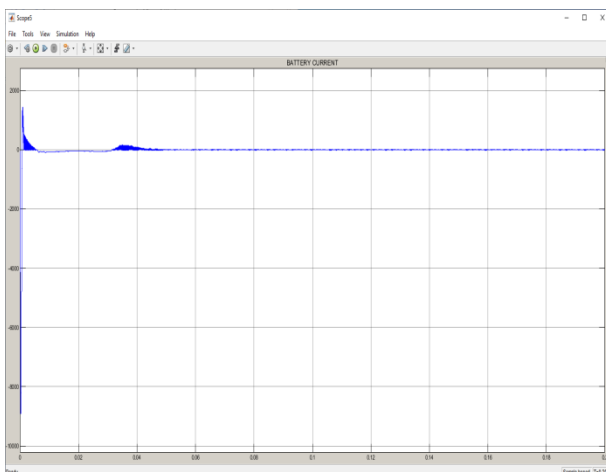

Fig 27. Battery current.

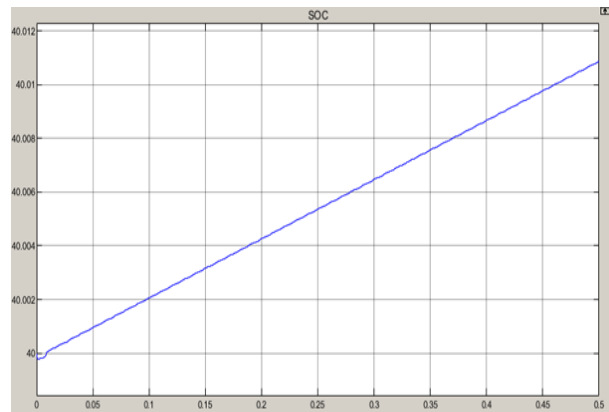

Fig 28. SOC charging at 40%

In the simulation 4 SOC condition check to check the SOC of the battery in the first case If soc between 0 to 25% , it will charge showing in fig 23

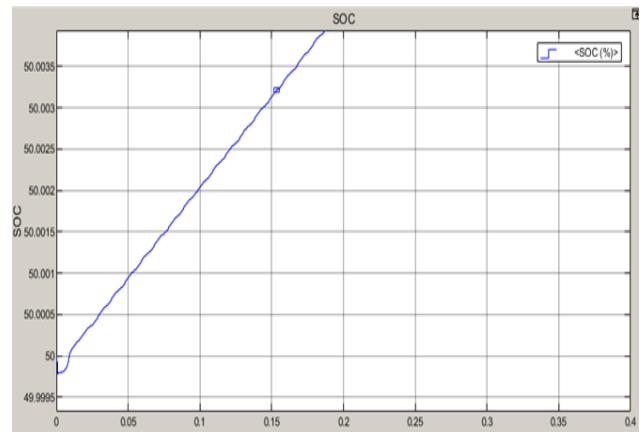

Fig 29. SOC charging at 50%

In the third case If soc between 50% to 90%, it will charge showing in fig 24.

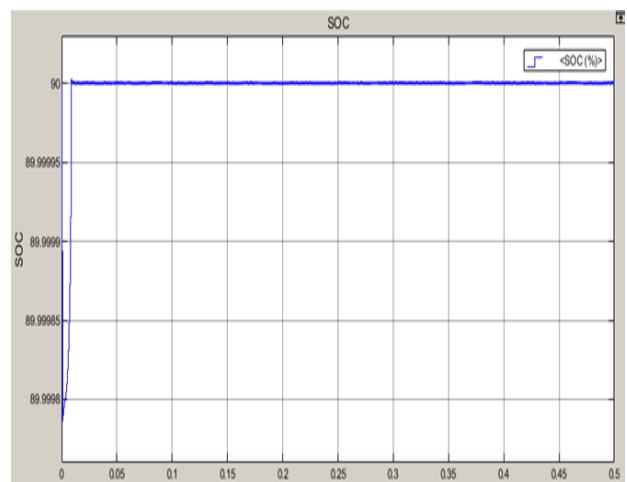

Fig 30. SOC charging at 90%

In the third case If soc between 50% to 90%, it will charge showing in fig 25.

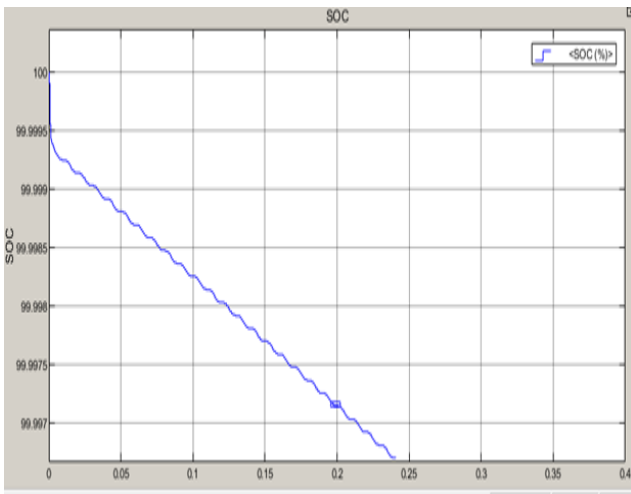

Fig 31. SOC discharging at 100%

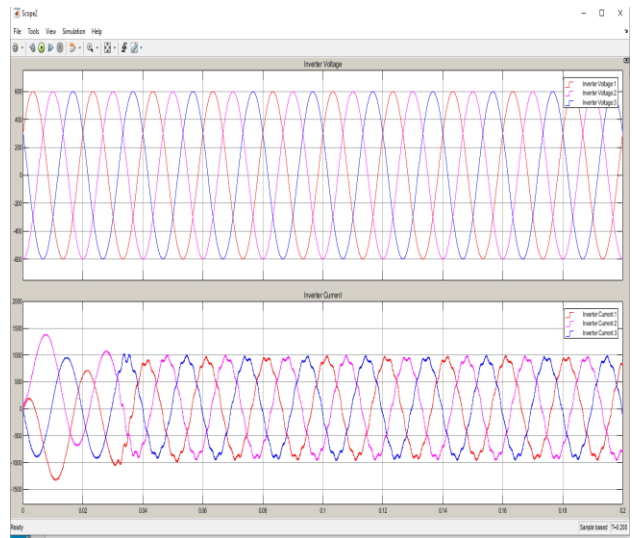

Fig 34. Inverter voltage and current.

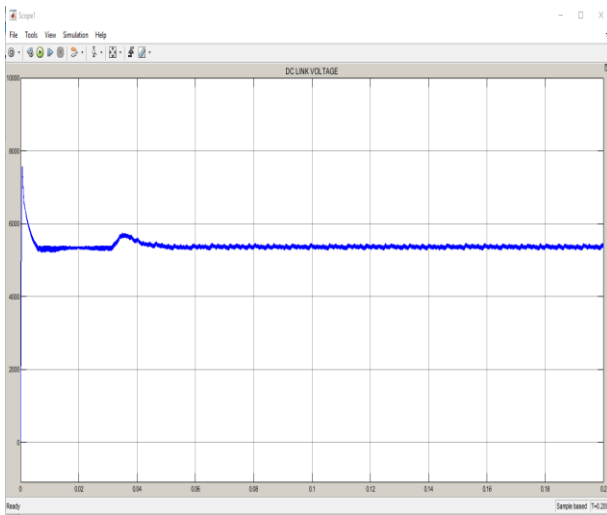

Fig 32. DC link voltage.

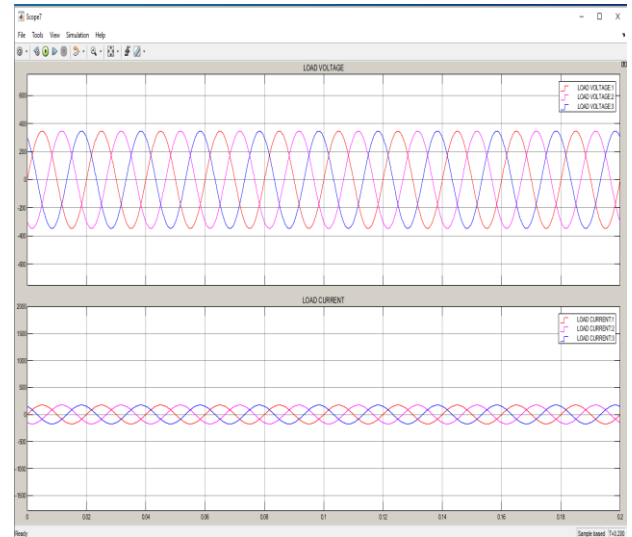

Fig 35. Load voltage and current.

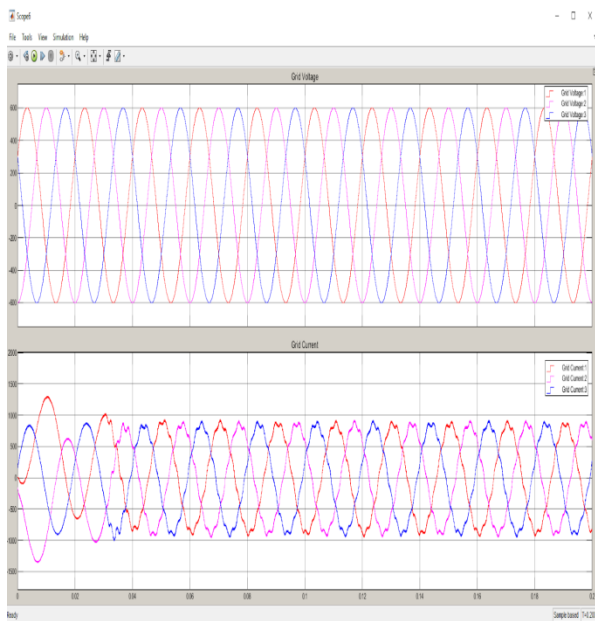

Fig 33. Grid voltage and current.

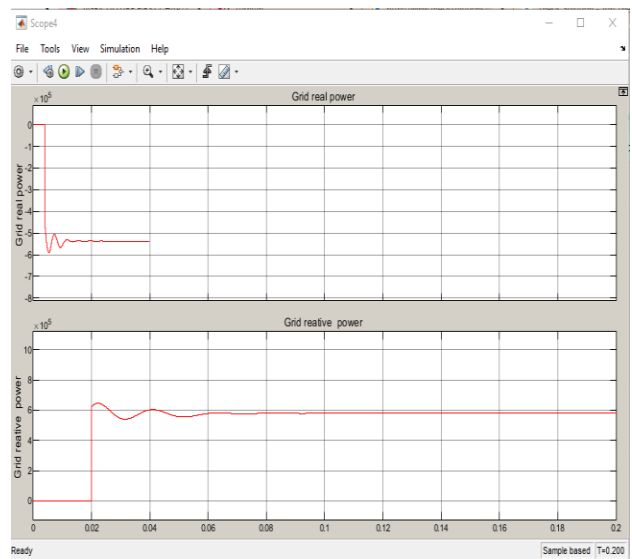

Fig 36. Grid real power and reactive power.

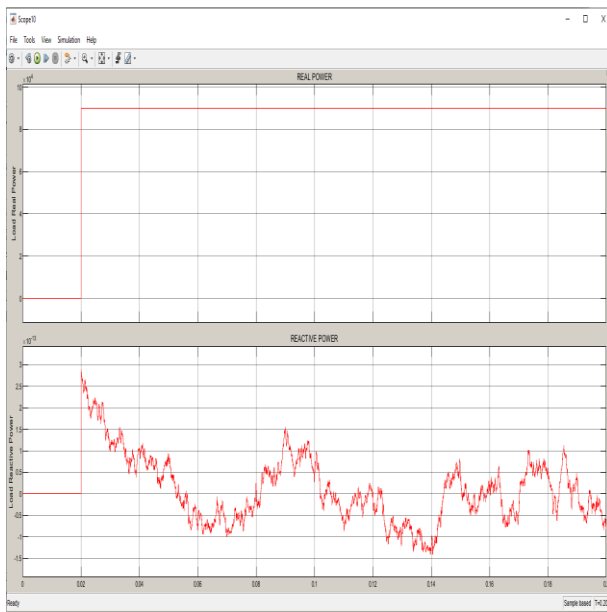

Fig 37. load real power and reactive power.

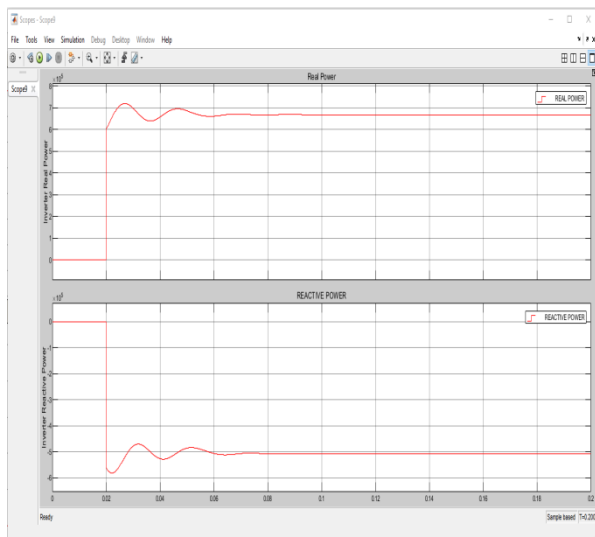

Fig 38. Inverter real power and reactive power.

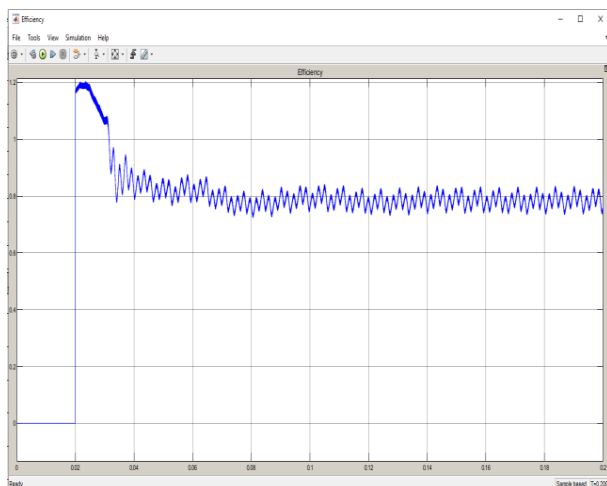

Fig 39. System efficiency.

## V. CONCLUSION

The suggested converter sent and received alternating current from and to the grid with a power factor of one and very few current harmonics, which kept the converter and battery's lives longer and kept the grid voltage from being distorted. V2G interactions, which can be used to make the grid run more efficiently, are also possible with this device. The suggested converter sent and received alternating current from and to the grid with a power factor of one and very few current harmonics, which kept the converter and battery's lives longer and kept the grid voltage from being distorted. V2G interactions can also be used to make the grid run more efficiently.

There is a 180-degree phase difference between the voltage that is coming into the grid and the flow of electricity that is coming out. In this case, the voltage in the grid and the current that is being injected are still the same at zero crossovers. These pictures show what the DC voltage bus would look like if it was filled up. When the load changes quickly, there are short voltage spikes. The converter keeps the voltage across the DC bus stable while supplying or taking in the right amount of current. There are findings that show how the voltage of a battery changes when it is charging and when it is discharging.

Within the scope of this work, DFIG was used to come up with a new way to control the frequency of a microgrid. At the time of the disturbance, the frequency of the Microgrid was controlled well by the droop control in the GSC and the BESS connected to the DC link of the back-to-back converter of the DFIG. Because the droop control was added to the GSC of DFIG, the wind turbine could always run at the point where it could get the most power. At the same time, the BESS sent the power that was needed to control the frequency. In both super-synchronous and sub-synchronous operation, the droop control did a great job of controlling the frequency.

When compared to the frequency of the microgrid that was running before the DFIG got involved, these results included a decrease in both the accommodation times and the frequency nadir. When BESS is used, on the other hand, the wind system might be able to work better. This is because the battery can be charged while the DC link voltage is controlled by BESS when DFIG is connected to the network and in super-synchronous mode. This makes sure that the battery always has enough power stored to help regulate the frequency. Last but not least, BESS drains the battery to control the voltage of the DC connection so that sub-synchronous operation can happen.

The amount of energy used around the world is going up, and at the same time, the amount of energy made by wind has been steadily going up. Wind power is becoming more and more seen as both a good addition to big conventional power plants and a good alternative to them. The

electricity made by wind energy systems needs to be fed into the grid, so there needs to be a way for wind energy systems and the grid to talk to each other. Power electronics, which act as a bridge, are needed not only for the renewable energy source but also for how it affects the way the power system works. This is because wind energy systems are a source of energy that only works sometimes.

Power electronics is a very important part of adding renewable energy sources to the electrical grid. This technology is used by a lot of people and is growing quickly as these applications become more and more connected to the grid systems.

The first wind turbines used a type of generator called a squirrel cage induction generator (SCIG) that was directly connected to the grid. This was the main piece of technology that was used. This almost makes it possible to connect the wind power pulses to the electrical grid. The active and reactive powers, which are important for controlling frequency and voltage, were not being controlled at all. This thesis explains how regulated active power can be put into the system in a way that meets the needs of the grid. This was done by doing a thorough analysis of all the relevant literature.

## REFERENCES

- [1] M. Liserre, T. Sauter, and J. Y. Hung, "Future energy systems: Integrating renewable energy sources into the smart power grid through industrial electronics," *Industrial Electronics Magazine, IEEE*, vol. 4, no. 1, pp. 18-37, 2010.
- [2] R. Melício, V. Mendes, and J. Catalão, "Modeling and simulation of wind energy systems with matrix and multilevel power converters," *Latin America Transactions, IEEE (Revista IEEE America Latina)*, vol. 7, no. 1, pp. 78-84, 2009.
- [3] L. Xu, "Control of power converter for grid integration of renewable energy conversion and STATCOM systems," *The University of Alabama TUSCALOOSA*, 2009.
- [4] S. Nath, and S. Rana, "The Modeling and Simulation of Wind Energy Based Power System using MATLAB," *International Journal of Power System Operation and Energy Management*, vol. 1, 2011.
- [5] S.-H. Song, S.-i. Kang, and N.-k. Hahm, "Implementation and control of grid connected AC-DC-AC power converter for variable speed wind energy conversion system." pp. 154-158, 2013.
- [6] P. Matić, A. Rakić, and S. N. Vukosavić, "Space vector representation of induction motor model in field weakening regime," *Serbian Journal of Electrical Engineering*, vol. 9, no. 1, pp. 53-61, 2012.
- [7] Kishore, and G. S. Kumar, "A Generalized State-Space Modeling of Three Phase Self- Excited Induction Generator For Dynamic Characteristics and Analysis." pp. 1-6, 2010.
- [8] W. Emar et al., "V/F Control of Squirrel Cage Induction Motor Drives Without Flux or Torque Measurement Dependency," *International Journal of Robotics and Automation (IJRA)*, vol. 2, no. 2, pp. 77, 2011.
- [9] H. Kubota, K. Matsuse, and T. Nakano, "DSP-based speed adaptive flux observer of induction motor," *Industry Applications, IEEE Transactions on*, vol. 29, no. 2, pp. 344- 348, 1993.
- [10] J. L. Domínguez-García et al., "Indirect vector control of a squirrel cage induction generator wind turbine," *Computers & Mathematics with Applications*, vol. 64, no. 2, pp. 102-114, 2012.
- [11] R.-J. Wai, and K.-M. Lin, "Robust decoupled control of direct field-oriented induction motor drive," *Industrial Electronics, IEEE Transactions on*, vol. 52, no. 3, pp. 837-854, 2005.
- [12] G. Singh, K. Nam, and S. Lim, "A simple indirect field-oriented control scheme for multiphase induction machine," *Industrial Electronics, IEEE Transactions on*, vol. 52, no. 4, pp. 1177-1184, 2005.
- [13] G. S. Buja, and M. P. Kazmierkowski, "Direct torque control of PWM inverter-fed AC motors-a survey," *Industrial Electronics, IEEE Transactions on*, vol. 51, no. 4, pp. 744- 757, 2004.
- [14] J. N. Nash, "Direct torque control, induction motor vector control without an encoder," *Industry Applications, IEEE Transactions on*, vol. 33, no. 2, pp. 333-341, 1997.
- [15] S. Muller, M. Deicke, and R. W. De Doncker, "Doubly fed induction generator systems for wind turbines," *Industry Applications Magazine, IEEE*, vol. 8, no. 3, pp. 26-33, 2002.
- [16] Tapia et al., "Modeling and control of a wind turbine driven doubly fed induction generator," *Energy Conversion, IEEE Transactions on*, vol. 18, no. 2, pp. 194-204, 2003.
- [17] Y. Lei et al., "Modeling of the wind turbine with a doubly fed induction generator for grid integration studies," *Energy Conversion, IEEE Transactions on*, vol. 21, no. 1, pp. 257-264, 2006.
- [18] S. M. Skeist, and R. H. Baker, "Doubly fed induction machine," *Google Patents*, 2005.
- [19] J. Yao et al., "An improved control strategy of limiting the DC-link voltage fluctuation for a doubly fed induction wind generator," *Power Electronics, IEEE Transactions on*, vol. 23, no. 3, pp. 1205-1213, 2008.
- [20] G. Abad et al., "Direct power control of doubly-fed-induction-generator-based wind turbines under unbalanced grid voltage," *Power Electronics, IEEE Transactions on*, vol. 25, no. 2, pp. 442-452, 2010.