

# VLSI Architecture for 8-bit Reversible Arithmetic Logic Unit based on Programmable Gate

M.Tech.Scholar Sameer Suman, Dr. Anshuj Jain(HOD)

Department of Electronics and Communication,  
Scope college of Engineering  
Bhopal,M.P.,India

**Abstract-** Reversible computing spans computational models that are both forward and backward deterministic. These models have applications in program inversion and bidirectional computing, and are also interesting as a study of theoretical properties. A reversible computation does, thus, not have to use energy, though this is impossible to avoid in practice, due to the way computers are build. It is, however, not always obvious how to implement reversible computing systems. The restriction to avoid information loss imposes new design criteria that need to be incorporated into the design; criteria that do not follow directly from conventional models. In this paper, investigate garbage-free reversible central processing unit computing systems to physical gate-level implementation. Arithmetic operations are a basis for many computing systems, so a proposed the design of adder, sub tractor, multiplexer, encoder and work towards a reversible circuit for general circuit are important new circuits. In all design implemented Xilinx software and simulated VHDL text bench.

**Keywords-** Reversible Gates, Arithmetic Logic Unit (ALU), Ancilla Input, Delay.

## I. INTRODUCTION

Quantum Computation and Quantum Information is the study of the information processing tasks that can be accomplished using Quantum mechanical systems. Quantum mechanics is a mathematical frame work or set of rules for the construction of physical theories. Quantum computation taught us to think physically about computation, and this approach yields many new and exciting capabilities for information processing and communication. In the broadest terms, any physical theory, not just Quantum mechanics, may be used as the basis for a theory of information processing and communication. One of the messages of Quantum computation and information is that new tools are available for those problems that are relatively more difficult or impossible to solve on Classical computers. Quantum computing believes that what is computable and what is not computable is limited by the Laws of physics [1].

Traditional computer science is based on Boolean logic and algorithms. Its basic variable is a bit with two possible values, 0 or 1. These values are represented in the computer as stable saturated states off or on. Quantum mechanics offer a new set of rules that go beyond this classical paragraph [2].

The basic variable is now a qubit, represented as a vector in a two dimensional complex Hilbert space. '0' and '1' form a basis in this space. The logic that can be implemented with such qubits is quite distinct from Boolean logic, and this is what has made Quantum computing exciting by

opening new possibilities. A related historical strand contributing to the development of quantum computation and quantum information is the interest, dating to the 1970s, of obtaining complete control over single Quantum systems [3].

Applications of Quantum mechanics prior to the 1970s typically involved a gross level of control over a bulk sample containing an enormous number of Quantum mechanical systems, none of them directly accessible. Since the 1970s many techniques for controlling single Quantum systems have been developed. For example, methods have been developed for trapping a single atom in an 'atom trap', isolating it from the rest of the world and allow us to probe many different aspects of its behavior with incredible precision [4].

Quantum computation and Quantum information provide a useful series of challenges at varied levels of difficulty for people devising methods to better manipulate single quantum systems, and simulate the development of new experimental techniques.

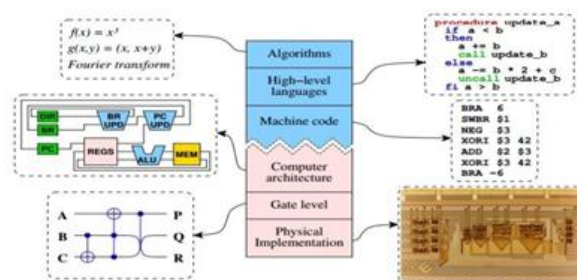

Fig 1. Reversible Computing System.

The ability to control single quantum systems is essential if we are to harness the power of quantum mechanics for applications to Quantum computation and Quantum information. Despite this intense interest, efforts to build Quantum information processing systems have resulted in modest success to date. Small Quantum computers, capable of doing dozens of operations on a few qubits represent the state of the art in Quantum computation. However, it remains a great challenge to physicists and engineers to develop techniques for making large-scale Quantum information processing a reality [5].

In his 1961 paper, Landauer wrote that “we shall label a machine as being logical reversible, if and only if all its individual steps are logically reversible” [6].

This is a very grand challenge and we know from Bennett (and later work) that, theoretically, such machines do exist – even when we add the requirement that the final result must not include garbage. But is it possible to realize such machines in practice and can it be done with the fabrication technology that exists today? And will we actually be able to achieve the expected reduced heat dissipation?

The Micro Power research project [7], which started in 2009, has as objective to develop a proof-of-concept reversible computing system and the computer science theory behind it. To do this all parts of the reversible computation tower (Figure 1.1) must be investigated. More specifically, the project investigates whether reversible computing can be applied in a power-limited application (specifically hearing aids) with the future hope to either reduce power consumption or increase functionality [8].

## II. ARITHMETIC LOGIC CIRCUITS

Arithmetic operations lie at the foundation of most computing systems and good logical implementations of these are important. Improvements to arithmetic circuits can result in improvements to the entire computing system. In a garbage-free reversible computing system it is especially important that the arithmetic circuits are also garbage-free, but how to do this is not always obvious, and history shows that rethinking our current knowledge can be necessary.

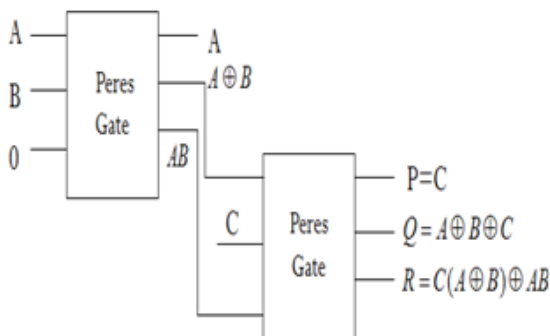

Fig 2. Block Diagram of 1-bit Full Adder.

The adder that Feynman proposed [9] was a reversible embedding of the ripple-carry adder. Though addition is an injective function if one of the inputs is kept, the conventional ripple-carry structure is not reversible. The problem lies in the use of the full-adder circuit, because it is not possible to calculate both the sum and the carry without copying one of the inputs. You can say that there is an overlap in the information contained in the two results and these results in a garbage bit. Several reversible adder designs used this ripple structure; e.g. reversible binary-coded decimal adders have received some interest.

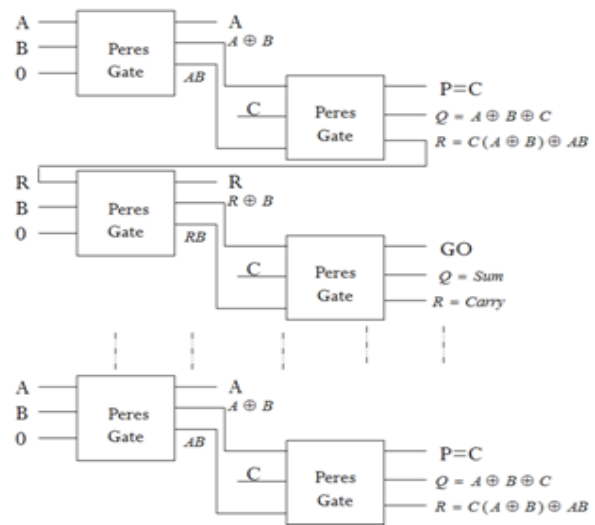

Fig 3. Block Diagram of n-bit Full Adder.

Addition has an intuitive reversible formulation using modular arithmetic and reversible updates. Multiplication, on the other hand, is more difficult to define; mainly because the inverse operation is division. A simple way to define it is to take the embedding from Bennett and save both the multiplicand and the multiplier while still producing the product. This is the trick used by Kawada et al. in their (garbage-free) reversible logic implementation of the Karatsuba algorithm.

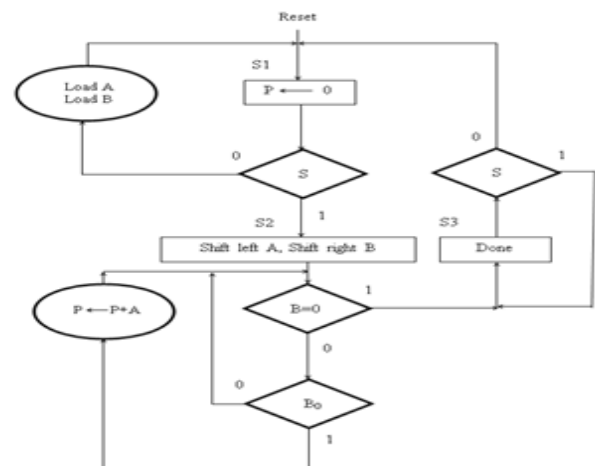

Fig 4. ASM Flow Chart of Multiplier.

Multimedia transforms are an interesting application area for reversible circuits. In small battery-powered devices (e.g. smartphones and mp3-players) they are often included as part of an ASIC to reduce power consumption and a key property of many such transforms is that they are information-lossless (and thus invertible). There exist many application areas of such transforms and even the earliest quantum algorithms make use of a quantum implementation of the Fourier transform. Also a implementation of the fast Fourier transform in reversible logic has been investigated.

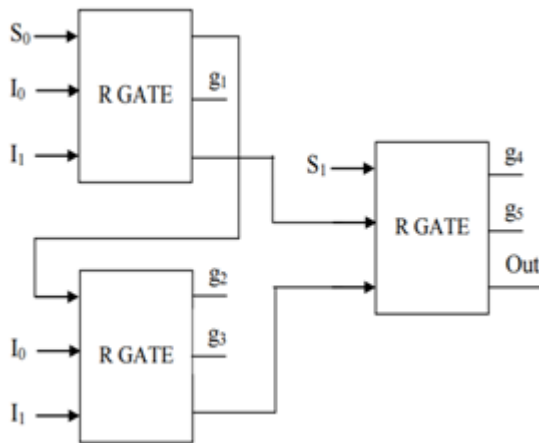

Fig 5. Proposed Diagram of 4x1 Multiplexer.

The first approach to reversible logic synthesis is actually a very beautiful example of how mathematics can be related to reversible circuits. Based on work by Rayner and Newman, Storme and De Vos used that reversible gates and cascading of these by serial composition forms a group, with the result that it is possible to use the known methods from group theory. Specifically, one of these methods can be used to decompose an arbitrary reversible circuit into a cascade of simpler circuits that only updates one input wire.

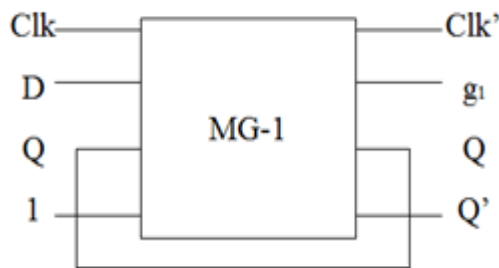

Fig 6. Proposed 1-bit Memory Store Element.

Reversible logic synthesis have since been much researched and often with an interest to also apply the methods to quantum circuits. Many of the approaches is based on techniques known from Boolean logic synthesis. There exists many more, but common to these are that they are based on truth tables as input and that they actually try to solve an NP-hard problem.

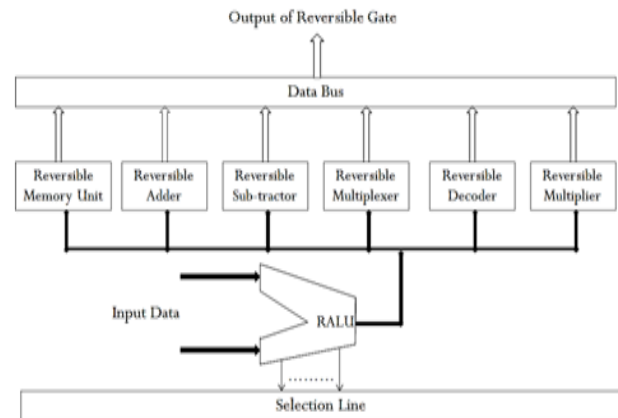

Fig 7. Flow Chart of Arithmetic Logic Unit.

According to base paper, the use different technique used for central processing unit (CPU) using arithmetic logic unit (ALU) and different types of reversible logic gate. In base paper generally concentrate on the number of slice (area), number of look up table (LUT) and maximum combination path delay (MCPD) of the central processing unit. In this dissertation proposed central processing unit based TR gate and used to multiplier, adder, sub tractor, multiplexer and encoder. So step by step explain proposed design is below:

- Layout the data bus to handle all of the operations of the reversible ALU.
- Design the reversible realizations of the flip-flops.
- Design the reversible memory circuits (such as buffer registers and counter circuits) using the proposed reversible flip-flops of the previous step.
- Design the arithmetic circuits such as adder, multiplier, divider, comparator etc.
- Design the reversible realization of ALU.
- Design the reversible control unit of the processor by designing an efficient instruction decoder.

### III. SIMULATION RESULT

More specifically, we have developed new garbage-free circuits for addition and are working towards a general multiplication circuit. We have also combined multiple operations together to implement a reversible arithmetic logic unit. With these and other garbage-free arithmetic circuits it is possible to design larger reversible computing systems. As an example, we have implemented discrete lossless transforms by redesigning these with a lifting scheme. We have also shown the design of a reversible computing architecture and implemented this using only reversible logic gates. While, these are still small systems, with further development it should be possible to use similar strategies to implement even larger systems.

#### 1. Reversible Gate Parameter:

**1.1 Gate Count (GC):** The number of gates used to realize reversible circuit

- 1.2 **Garbage Outputs (GO):** The number of unused outputs in a reversible logic. The inputs regenerated at the outputs are not garbage outputs.
- 1.3 **Ancilla Inputs (AI):** The number of input kept constant at either 0 or 1.
- 1.4 **Delay:** It corresponds to number of primitive quantum gates in the critical path of the circuit.
- 1.5 **Quantum Cost:-**Quantum cost is defined, as the number of basic quantum gates like controlled-NOT, Controlled V+, Controlled V and NOT gate.

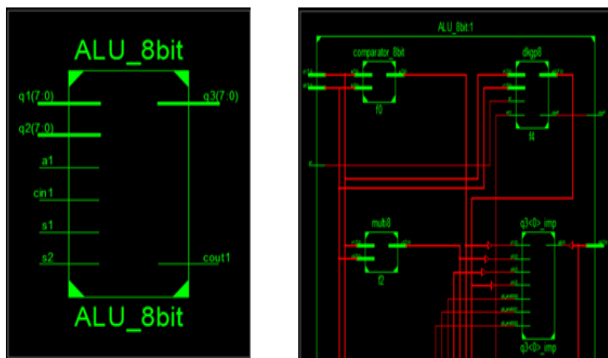

Fig 8. VTS for 8-bit RALU AND RTL View for 8-bit RALU.

The proposed irreversible and reversible multiplier circuit is more effective than the current configuration. The proposed irreversible and reversible multiplier circuit is separated two section i.e. fractional item and multi-operand expansion. The proposed halfway item is minimize 5 quantum cost in the configuration. Build the number piece of the reversible multiplier circuit so lessened the quantum cost. Table1 shows the result of 4-bit reversible adder/sub-tractor.

Table 1. Comparative Results of Existing Algorithm and Proposed Algorithm in 4-bit Adder/ Subtractor.

Parameter	Existing Adder/ Sub-tractor [1]	Proposed Reversible Adder/ Sub-tractor
No. of Gates	44	40
Garbage Output (GO)	8	8
Quantum Cost	28	24

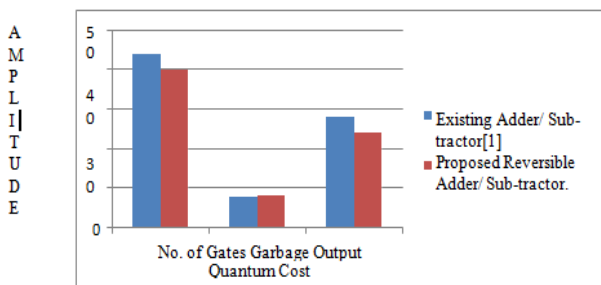

Fig 9. Bar Graph of the Previous and Proposed Reversible Full Adder.

Table 2. Comparative Results of Existing Algorithm and Proposed Algorithm in 8-bit Adder Subtractor.

Parameter	Existing Adder/ Sub-tractor[1]	Proposed Reversible Adder/ Subtractor
No. of Gates	44	80
Garbage Output (GO)	16	16
Quantum Cost	56	48

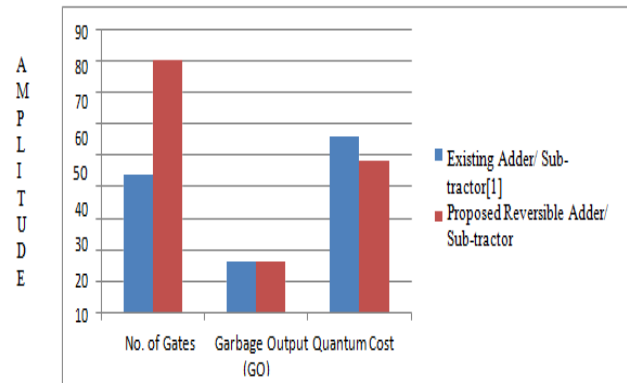

Fig 10. Graph of the Previous and Proposed Reversible Full Sub-tractor.

#### IV. CONCLUSION

For conventional logic circuits there exists much research, even whole books, dedicated to the design and implementation of computer arithmetic. This is definitely not the case for reversible logic. The constraint that the circuits must be garbage-free is what makes it an interesting research problem, but most proposed designs (both handmade and CAD generated) still implement the conventional algorithms with garbage. They use the reversible gates, but as their sole goal is to reduce logic size or number of garbage bits for a specific fixed-size circuit, very little knowledge is actually gained from this approach.

#### REFERENCES

- [1] Vandana Shukla, O.P. Singh, G.R. Mishra and R.K. Tiwari, "Design and Performance Analysis for the Reversible Realization of Adder/Subtractor Circuit", International Conference on Emerging Trends in Computing and Communication Technologies (ICET CCT), IEEE 2017.
- [2] Jayashree HV and Ashwin S, "Berger Check and Fault Tolerant Reversible Arithmetic Component Design", International Conference on Electron Devices and Solid-State Circuits (EDSSC), IEEE 2015.
- [3] Hatkar A.P., Hatkar A. A. and Narkhede N. P., "ASIC Design of Reversible Multiplier Circuit", International Conference on Electronic Systems, Signal Processing and Computing Technologies, IEEE 2014.

- [4] Matthew Morrison and Nagarajan Ranganathan, "Design of a Reversible ALU based on Novel Programmable Reversible Logic Gate Structures", Computer Society Annual Symposium on VLSI IEEE 2013.
- [5] Shefali Mamataj Biswajit Das Anurima Rahaman "An Approach for Realization of 2's Complement Adder Subtractor Using DKG Reversible Gate" International Journal of Emerging Technology and Advanced Engineering vol.3 no.12 pp. 205-209 December 2013.
- [6] Mr. Abhishek Gupta, Mr. Utsav Malviya and Prof. Vinod Kapse, "Design of Speed, Energy and Power Efficient Reversible Logic Based Vedic ALU for Digital Processors", Computer Society Annual Symposium on VLSI, IEEE 2012.
- [7] Lekshmi Viswanath and Ponni.M, "Design and Analysis of 16-Bit Reversible ALU", International Conference on VLSI Circuit and Digital Signal Processing, Vol.1, Issue1, PP:46-53, 2012.
- [8] M.Morrison and N.Ranganathan,"Design of a Reversible ALU Based on Novel Programmable Reversible Logic Gate Structures", IEEE International Symposium on VLSI, pp.126-131, IEEE 2011.
- [9] Md.Belayet Ali, Hosna Ara Rahman and Md. Mizanur Rahman, "Design of a High Performance Reversible Multiplier", IJCSI International Journal of Computer Science Issues, Vol. 8, Issue 6, No 1, November 2011.
- [10] Michael Nachtigal, "Design of a Reversible Floating-Point Adder Architecture", 11th IEEE International Conference on Nanotechnology Portland Marriott, IEEE 2011.
- [11] Maher Hawash, Marek Perkowski, Steve Bleiler, John Caughman, and Amjad Hawash, "Reversible function synthesis of large reversible functions with no ancillary bits using covering set partitions", information Technology: New Generations, Third International Conference, IEEE 2011.
- [12] D.Maslov and M.Saeedi. Reversible circuit optimization via leaving the boolean domain. Computer Aided Design of Integrated Circuits and Systems, IEEE Transactions on, 30(6):806–816, June 2011.
- [13] H.R. Bhagyalakshmi, M.K.Venkatesha, "An Improved Design of A Multiplier Using Reversible Logic Gates", International Journal of En