

A Review Article of Facts Based Islanding Phenomenon Reduction and Enhancement of Grid Efficiency

M.Tech. Scholar Kanupriya, Asst. Prof. Durgesh Vishwakarma

Dept. of Electrical and Electronics Engineering
Radharaman Engineering College (Rec) Ratibad Bhopal

Abstract – Islanding is undesired because it may impair the safety of maintenance service workers and/or damage load equipment through unsynchronized re-closure. In principle, islanding detection is the monitoring of islanding-indicating changes in inverter output parameters or other system parameters. This paper aims to aid design efforts through its comprehensive review of islanding detection methods (comparing their non-detection zones and detection speeds) and anti-islanding standards. As a result, this paper shall provide a handful information and clearer vision for researchers to determine the best method for their product.

Keywords– Distributed generation, grid protection, islanding detection method, review.

I. INTRODUCTION

Islanding detection for the protection of distributed generator fed systems that has been tested on power distribution busses of 25 kV and less. Recent interest in distributed generator installation into low voltage busses near electrical consumers has created some new challenges for protection engineers that are different from traditional radially based protection methodologies. Therefore, typical protection configurations need to be re-thought such as re-closures out-of-step monitoring, impedance relay protection zones with the detection of unplanned islanding of distributed generator systems.

The condition of islanding, defined as when a section of the non utility generation system is isolated from the main utility system, is often considered undesirable because of the potential damage to existing equipment, utility liability concerns, reduction of power reliability and power quality. Current islanding detection methods typically monitor over/under voltage and over/under frequency conditions passively and actively; however, each method has an ideal sensitivity operating condition and a non-sensitive operating condition with varying degrees of power quality corruption called the non detection zone (NDZ).

The islanding detection method developed in this thesis takes the theoretically accurate concept of impedance measurement and extends it into the symmetrical component impedance domain, using the existence of naturally and artificially produced unbalanced conditions. Specific applications, where this islanding detection method improves beyond existing islanding detection methods, are explored where a generalized solution allows the protection engineer to determine when this

method can be used most effectively. To start, this thesis begins with a brief introduction to power systems in North America and the motivation for the use of distributed generation. Further chapters then detail the background and specifics of this technique.

II. ISLANDING

Islanding is the situation in which a distribution system becomes electrically isolated from the remainder of the power system, yet continues to be energized by DG connected to it. As shown in the figure 2.1. Traditionally, a distribution system doesn't have any active power generating source in it and it doesn't get power in case of a fault in transmission line upstream but with DG, this presumption is no longer valid.

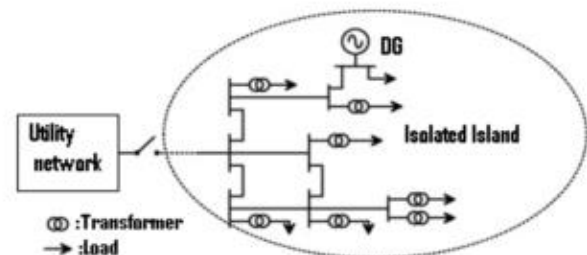

Fig.1. Scenario of Islanding operation.

Current practice is that almost all utilities require DG to be disconnected from the grid as soon as possible in case of islanding. IEEE 929-1988 standard [1-10] requires the disconnection of DG once it is islanded. Islanding can be intentional or Non intentional. During maintenance service on the utility grid, the shut down of the utility grid may cause islanding of generators. As the loss of the grid

is voluntary the islanding is known. Non-intentional islanding, caused by accidental shut down of the grid is of more interest. As there are various issues with unintentional islanding. IEEE 1547-2003 standard [5] stipulates a maximum delay of 2 seconds for detection of an unintentional island and all DGs ceasing to energize the distribution system

III. ISSUES WITH ISLANDING

Although there are some benefits of islanding operation there are some drawbacks as well. Some of them are as follows: Line worker safety can be threatened by DG sources feeding a system after primary sources have been opened and tagged out. The voltage and frequency may not be maintained within a standard permissible level. Islanded system may be inadequately grounded by the DG interconnection. Instantaneous reclosing could result in out of phase reclosing of DG.

As a result of which large mechanical torques and currents are created that can damage the generators or prime movers [6] Also, transients are created, which are potentially damaging to utility and other customer equipment. Out of phase reclosing, if occurs at a voltage peak, will generate a very severe capacitive switching transient and in a lightly damped system, the crest over-voltage can approach three times rated voltage.[7] Various risks resulting from this include the degradation of the electric components as a consequence of voltage & frequency drifts. Due to these reasons, it is very important to detect the islanding quickly and accurately.

IV. LITARATURE REVIEW

J Sreedevi, Ashwin N (2016) Photovoltaic (PV) energy has a fast growing annual rate and is quickly becoming an important part of the energy balance in most regions and power systems. This paper aims to study the effects of connecting a PV system to the grid through simulation of the system in RSCSD software in real time on the Real Time Digital Simulator (RTDS). Effect of variation of power factor of loads, variation of PV penetration, and introduction of harmonics into the system by the PV inverter and anti-islanding effect of the PV system are studied. Finally, the Performance Ratio (PR) of a typical grid connected PV system is evaluated to determine the reliability and grid connectivity of the PV system.

Dhanshree A. Diyewar (2016) One of the major drawback of connecting PV systems to the grid is unintentional islanding condition. Islanding can be dangerous for utility workers and damage utility equipment so anti islanding is a crucial subject for grid connected PV systems. For this reason inverter in the PV system must detect islanding and stop supplying power if the grid is down. In this paper 12 pulse Lee is used in inversion mode for the grid connection of PV system. A 12 pulse Lee converter needs

com mutating voltage of grid to operate. The Lee do not require maintaining synchronism between grid and converter and having an ability to suppress all harmonics below 11 th order. The simulation results is carried out in Matlab/Simulink shows feasibility of proposed solution.

Prashant Jain, Vivek Agarwal (2018) This paper presents an active anti-islanding scheme for grid-tied centralized inverters for large Photovoltaic (PV) power plants. The proposed technique involves appropriate reactive power injection into the grid which results in the positive/negative rate of change of frequency. The proposed algorithm is simple and can be easily integrated into DQ based current control technique. It has a smaller Non-Detection Zone (NDZ) and faster response as compared to other active anti-islanding schemes.

As the proposed method is based on alarm generation and confirmation, it does not inject any periodical disturbance into the grid unlike other anti-islanding techniques and thus does not cause any power quality issues. The proposed active anti-islanding algorithm is simulated in MATLAB/SIMULINK under different loading conditions as per IEEE/IEC standards. The algorithm is also experimentally verified on a 25 kW centralized inverter prototype using TMS320F2812 DSP controller. The experimental and simulation results are presented to validate the effectiveness of the algorithm.

Ahmed M. A. Haidar, Al-Khalid bin Hj Othman (2017) The widespread adoption of Renewable Energy Resources (RER) and Plug-in Electric Vehicles (PEVs) in distribution systems has achieved a substantial energy share, allowing the microgrid to participate in the open market. In fact, the high penetrations of RER and PEVs have increased the importance of impact assessment involving system protection. A framework is presented in this paper for modeling the combined operations of RER based solar Photovoltaic (PV) systems and PEVs in a microgrid integrated with power grid. The paper also proposes a fault current limiter connected in parallel (anti-islanding protection) with the circuit breaker in the point of common coupling (PCC), thus providing current bypass circuit during abnormal conditions. The concept of the proposed scheme is validated under various operating conditions using a 24-hourly dynamic simulation. The results demonstrate the effectiveness of the proposed approach.

Jongmin Jo, Hanju Cha (2017) In this paper, reactive power variation based on positive feedback is proposed for improving islanding detection in the distributed generation. The proposed reactive power variation method consists of two parts, where the first part has a fundamental amplitude as $+5\%P_{inv}$ or $-5\%P_{inv}$, and the second part has a positive feedback using a frequency deviation. Polarity and amplitude of RPV method are determined by a deviation between the measured

frequency at PCC and the rated frequency. For grid-connected operation, the amplitude corresponding to the positive feedback can be ignored since there is almost no frequency deviation.

Therefore, an only $+5\%P_{inv}$ or $-5\%P_{inv}$ is supplied to loads, and either positive or negative value may be switched by the measured frequency. Power factor is close to unity power factor as 0.9975. In islanding condition, the positive feedback affects changes of PCC frequency by increasing the absolute amplitude of RPV. Therefore, it makes PCC frequency deviate outside maximum or minimum threshold value rapidly. The direction of PCC frequency toward either maximum or minimum threshold value is determined in accordance with the polarity of the reactive power injected at the time of occurrence of islanding. Feasibility of the proposed RPV method is verified through experiments, where the detection times of islanding take 53ms in over-threshold value as 60.5Hz and 150ms in under-threshold value as 57Hz, respectively.

Daniel Motter, José Carlos M. Vieira (2016) The anti-islanding performance of the frequency protection is strongly affected by the power imbalance between the islanded loads and distributed generators. However, different scenarios of load profiles can create similar power imbalance levels inside the island, leading to different protection's detection time due to the difference on the load dynamic behavior. In this context, this paper investigates the influence of the variation of the load distribution, power factor and unbalance on the performance of an over frequency protection applied for islanding detection of a synchronous distributed generator. The results were obtained considering excess of active power in the island and constant impedance loads and they have shown that the performance of the protection scheme can be strongly affected by these load variations, and such issue should be taken into account to correctly adjust the frequency-based anti islanding protection.

Zhang Xiaolin, Zhang Zengqiang (2018) With the rapid development of photovoltaic industry, the performance detection of PV grid connected inverter is becoming more and more important in maintaining safe and stable operation, and the capability of anti-islanding is an important aspect of evaluating the performance of grid connected inverter. Based on existing methods and standards for inverter detection, by dividing interval of minimum fundamental wave current at grid connection point and introducing the load resonance frequency as the key test condition, This paper presents a refined detection method of photovoltaic inverter based on RLC circuit impedance characteristics, such as load resonant frequency and fundamental current variation, and weights comprehensive evaluation of multiple test results on the basis of fine detection. The method proposed in this paper

solves the problem that the protection capability of the photovoltaic inverter is difficult to be finely evaluated, and effectively avoids the phenomenon that some inverters can not correctly reflect the capability of the inverter anti anti-islanding for the characteristic load design. This method can comprehensively and objectively reflect the protection performance of the anti-islanding of the inverter. At the same time, it provides technical support for the existing protection performance detection methods of anti-islanding protection, and further enriches and perfects the related standard system of the protection performance detection field of the anti-islanding.

Abhijit R. Singare, BharatiMahindrakar (2017)A photovoltaic system also called solar PV power system is a system designed to supply usable solar power by means of photovoltaic cell. This paper presents a detailed study of Grid-connected photovoltaic system for power supply of institutional building in rural area. The process of acquiring power from PV panels involves a proper selection, design and determination with specifications of various components that are used in the system for confirming the load estimation. The completion of this process depends on different factors such as geographical location of institution, weather condition and solar irradiance at location along with load consumption at the institute. This paper gives complete procedure for specifying each components of the Grid-connected PV system and an institution in Wardha, India is selected for case study. Complete cost analysis which also includes installation and maintenance cost of a solar photovoltaic system has been carried out. It has been observed from the analysis that capital investment is high but payback period is less and after that it will gain consequential profit.

Kevin Ark Kumar, KinattungalSundareswaran (2015) Islanding is a condition in which a portion of electric power grid, containing both load and generation, is isolated from the remainder of the electric power grid. There are two types of islanding conditions- one is an intentional islanding created by the controlling authority to isolate a large section of the utility grid; the other is unintentional islanding, where the utility grid with a distributed generation system (DGS) and its load is alone isolated .

The major causes for unintentional islanding are faults, lightning, failure of equipment's, malfunctioning of protective switchgears etc. Among the DGS, majority of the systems are customer-owned generators, like solar photovoltaic systems, wind energy systems etc. As per regulations, these systems are required to sense the islanding condition to close down its operation and should cease to energize the grid A typical line The reasons for cease of operation of an islanded DGS are, to avoid electrical hazard for men-on-line; damage of utility equipments; the frequency and voltage may go out of

range that can destroy the customer equipment; islanding may interfere with restoration of normal services to neighbouring customers; customer DGS can be damaged if the main grid recloses into the island out of synchronization.

S. Bouchakour, F.CHERFA (2012) Algeria has created a green momentum by launching an ambitious program with an aim of developing renewable energies. This strategic choice is motivated by the huge potential of our solar energy, which is the major focus of the program where solar power and photovoltaic systems constitute an essential part. The use of solar energy should reach by 2030 more than 37% of national electricity production. If it's accomplished, the amount of PV systems in distribution systems is expected to grow and it could become comparable with the power supplied by the main source.

Therefore, PV systems could have serious consequences on important technical aspects such as quality of power supplied to customers by utilities, power control and utility protection schemes, islanding operation of the PV systems. In practice, the utility regulations dictate that PV systems should operate at a power factor greater than 0.85 (leading or lagging), when output is greater than 10% of rating. Thus, power quality caused by a large penetration of PV grid-connected systems becomes an important issue. In this work, the power quality behaviour of grid connected PV systems has been investigated. The solar photovoltaic system power plant, currently in service, was achieved in cooperation with the Spanish Agency for International Development Cooperation (AECID). The installation is located on the roof of CDER in Bouzaréah, Algiers (latitude 36.8°N, longitude 3°E and 345m of altitude). It started operating on June 21, 2004; the electricity produced by photovoltaic solar panels is injected directly into the SONELGAZ grid without storage device.

Rami J. Haddad, YouakimKalaani (2018) Distributed Generation (DG) sources have become an integral part of today's decentralized power systems. However, current DG systems are mostly passive and do not provide intelligent information to help detect power quality issues. In this paper, a novel and intelligent event classification scheme is proposed to provide DG systems with real-time decision-making capabilities. The proposed technique has the ability to provide information to help maintain the quality and reliability of DG systems under various disturbances or operating conditions. This event classification technique was developed using artificial neural networks (ANN) with a pre-defined set of local input parameters. The algorithm is implemented using four parallel ANNs that were designed to operate under a majority vote fusion algorithm representing the final classification output. A total of 310 event cases were generated to test the performance of the proposed

technique. Simulation results showed that events were accurately classified within 10 cycles of their occurrences while achieving a 96.21% average classification accuracy.

Mrs.P.S.Gotekar Since the photovoltaic systems development is growing exponentially, the policies related to grid integration will also have to change so that more and more PV systems can be accommodated in the grid. This paper discusses existing Central Electricity Authority (CEA) technical interconnection regulations. As PV penetration increases the CEA can reevaluate the existing operating range for voltage and current factoring the operating conditions in India. Additional features which provide system benefit like reactive power support for an improved voltage profile, intentional islanding, fault ride through capabilities can be thought of. A comparison of transformer less inverters for specific topologies is carried out.

This review paper studies the grid regulations as defined by the CEA. PV systems with transformer in comparison to transformer less PV inverter systems have less efficiency and that they have galvanic isolation. The common mode behaviour influences ground leakage current. The problem associated with common mode voltage behaviour is dependent on topology structure. The variation in common mode voltage influences leakage current through stray capacitance. The performance of different transformer less inverters for specific topologies are carried out based on the comparison of efficiency, leakage current, common mode voltage and switching frequency is studied and presented.

Shivam Prakash Gautam: The interest in development of newer topologies of multilevel inverter has been increasing rapidly in past few years. Recently introduced topologies achieve higher number of output voltage steps with reduced number of switches, DC voltage sources, voltage stress across switches and losses as compared with the conventional topologies. In this study, a new structure of symmetrical multilevel inverter is proposed. The proposed structure offers reduced number of controlled switches, power diodes and DC sources as compared with classical and recently proposed topologies in the literature. Reduction of switch count and DC voltage sources reduces the size, cost, complexity and enhances overall Performance. Proposed topology is capable of producing 7, 9 and 11 levels of output voltage with seven switches only.

Moreover, significant reduction in voltage stress across the switches can be achieved. A comparative analysis of proposed topology with the conventional topology and recently published topologies has been made in terms of controlled switches, power diodes, driver circuit requirement, DC voltage sources and blocking voltage. Multi-carrier pulse-width modulation strategy is adopted for generating the switching pulses. Simulation study of the proposed topology has been carried out using

Matlab/Simulink and feasibility of topology has been validated experimentally.

Biju K:In current global energy scenario, renewable energy sources can play an important role in meeting the ever increasing energy demand. This is due to exhaustive nature of fossil fuels and the environmental pollution caused by other conventional energy sources. Among renewable energy sources, solar photo-voltaic system is the most popular one as solar energy is available in abundance without paying any cost. The output voltage generated from the solar panels depends on solar irradiance level and temperature. This paper intends to present a novel solar PV/battery hybrid energy system with a single phase five level inverter. The battery is used as a backup source when in case solar power is absent. The power flow through the battery is controlled using a bidirectional converter so that the optimum usage of the battery is ensured.

The proposed configuration uses a modified single phase five level inverter topology for converting DC voltage generated from solar photovoltaic/battery energy sources to AC voltage for feeding to the load. The usage of five level inverter reduces Total Harmonic Distortion (THD) in output voltage and thus eliminates the use of bulk filters at the output side. Simulation study of the proposed system is carried out using MATLAB Simulink. Simulation results for different cases are provided in this paper.

Nasrudin A. Rahim:This paper proposes a single-phase seven-level inverter for grid-connected photovoltaic systems, with a novel pulse width-modulated (PWM) control scheme. Three reference signals that are identical to each other with an offset that is equivalent to the amplitude of the triangular carrier signal were used to generate the PWM signals. The inverter is capable of producing seven levels of output-voltage levels (V_{dc} , $2V_{dc}/3$, $V_{dc}/3$, 0 , $-V_{dc}$, $-2V_{dc}/3$, $-V_{dc}/3$) from the dc supply voltage. A digital proportional-integral current-control algorithm was implemented in a TMS320F2812 DSP to keep the current injected into the grid sinusoidal. The proposed system was verified through simulation and implemented in a prototype.

V. METHODOLOGY FOR DETECTION

1. Passive Islanding Methods

The passive techniques look for some parameter deviations like voltage magnitude, rate of change of frequency, and harmonics, or Phase angle displacement. In the islanding mode, these parameters vary largely at the PCC. The difference between the grid-connected and islanding mode depends on the setting of the threshold values. A lower setting for the threshold for the permissible disturbances in these quantities may cause nuisance tripping. On the other hand, if the setting is too

high, then the protective devices will not respond to the islanding condition. The merits of these methods are the fast response and the absence of system disturbances. However, these methods have the disadvantage of having a large non-detectable zone (NDZ) and these protective methodologies might have variable or unpredictable reaction times. More specific passive anti-islanding methods can be discussed as follows.

2. Under/over Voltage and under/over Frequency

Under/over frequency protection techniques (UOF) and under/over voltage protection techniques (UOV) are required for all grid-connected PV inverters. These UOF/UOV protective devices are used as anti-islanding detection techniques and also used to protect the equipment of customers. In Figure 5.1, the system configuration of a PV inverter that is connected to a variable load is shown. When the PV-inverter is connected to the grid, the active and reactive powers ($P_t + jQ_t$) are delivered by the PV.

If the PV power rating is lower than the load power, then the power differences (ΔP and ΔQ) will be supplied from the utility grid. In the case of islanding, a mismatch of some parameters as voltage and frequency will occur. This behavior of this method may vary depending on ΔP and ΔQ . For more details, if ΔP is not equal to zero then the voltage amplitude at PCC will deviate and the islanding will be detected by the UOV protective relay. Similarly, the phase voltage at PCC changes when ΔQ is not equal to zero, causing a frequency deviation.

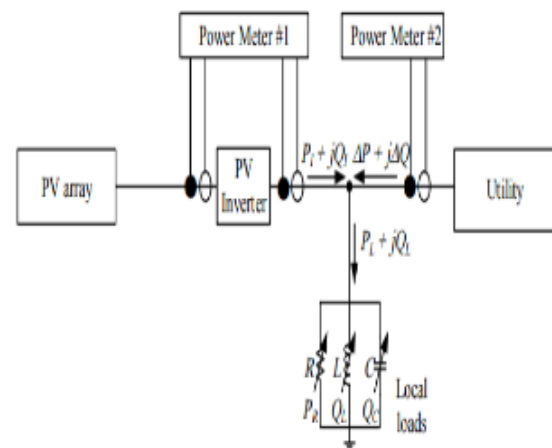

Fig .2. The test circuit for the islanding detection function in a photovoltaic (PV) power inverter.

Additionally, the UOF protection relays will then detect these variations and, consequently, islanding will commence. If the power differences are too large, both voltage and frequency exceed the adjusted limits of the UOF/UOV protective devices, which ultimately trips the circuit breaker. In cases of small differences between the

load power and the PV output power, this method may not be able to detect islanding due to the large NDZ. An example of NDZ is given in Figure 4.3; the mismatch regions of the power components are represented by the shaded area where this method cannot detect the islanding events.

3. Inverter across RMS voltage variation Islanding Detection:

The system considered in the proposed islanding detection periodically perturbs the inverter reference q-axis current to be 10% more than the current reference value at one line cycle and, in the next line cycle, the current reference value is decreased by the same value, as shown in Figure 5.2. This method maintains the inverter average output power to be constant so as to not deteriorate the controlling process. For several cycles, the reference current command is set to be nominal without perturbation.

This process is implemented regularly with the same intervals as shown in Figure 3.5. In a string of consecutive line cycles, if the measured RMS output voltage is different from the nominal value, the islanding factor is incremented steadily to the maximum value in which the inverter is tripped. The islanding factor is set to zero during the grid connection time when the rigid grid voltage forces the inverter terminal voltage to be equal to the grid voltage.

On the other hand, without perturbing the current, the inverter voltage remains unchanged during the islanding mode. Therefore, the increases and decreases in the reference current make the RMS output voltage deviate from the nominal value when the grid is lost. As a result, the islanding factor increases and the inverter is deactivated when the factor exceeds the threshold value. Sustainability 2018, 10, x FOR PEER REVIEW 8 of 15 from the nominal value when the grid is lost. As a result, the islanding factor increases and the inverter is deactivated when the factor exceeds the threshold.

The overall system configuration of the proposed islanding detection method comprises of the PV array, voltage source inverter (VSI), a low-pass filter, and a step-up Δ -Y transformer, as shown in Figure 3.5. The inverter circuit synchronizes the grid voltage with the inverter output current and its control unit is developed to implement the MPPT algorithm for extraction of the PV maximum power. To reduce the high-frequency switching harmonics of the perturbation signals on the grid voltage, line filters are included. To achieve the Power detection technique and a unity output power factor, the abc voltages and currents are transformed into a rotating dq reference frame synchronized with the grid voltages.

This reference frame is then used to represent the grid voltage and currents. The main point is adjusting the q-

axis current to trace the Inverter of the PV system, while the other current component is set to be zero to maintain the unity output power factor of the inverter output. Figure 5.2 shows the general control structure in the synchronous reference frame.

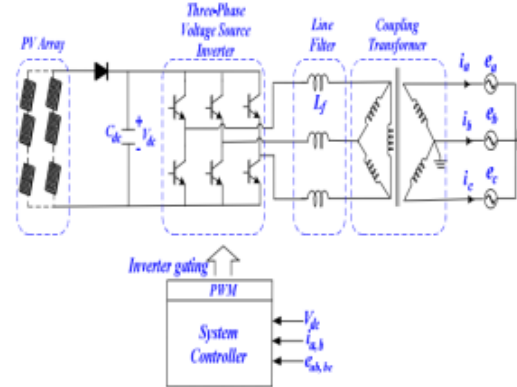

Fig.3.The power circuit for a PV system.

VI. CONCLUSION

Due to growing distributed generation penetration level at all voltage levels in the future Smart Grids there is an increased need for high performance islanding detection (anti-islanding protection) methods. A large non-detection zone near a power balance situation and unwanted distributed generation tripping due to other network events have been the major drawbacks of traditional, passive local islanding detection methods. Usually these traditional methods have also been dependent on the type of the distributed generation unit. In this paper the performance of three different possible future, local measurements based, passive islanding detection methods are compared. Performance comparison of these islanding detection methods is done in terms of size of non-detection zone, detection speed and possible detection speed dependency from power unbalance before islanding as well as possibility to mal-operate during frequency fluctuations and faults in the utility grid[10-12].

REFERENCES

- [1]. N. Panigrahy, Ilamparithi T., M. V. Kashinath, and R. Prakash, "Comparison and review of islanding detection techniques for power distribution studies," International Journal of Advanced Research in Electrical, Electronics and Instrumentation Engineering, vol. 5, no. 7, July, pp. 6485-6492, 2016.
- [2]. C. W. Yeau and Y. H. Tzer, "An integrated passive islanding detection method for distributed generators," WSEAS Transactions on Systems, vol. 8, no. 11, pp. 1207-1216, 2009.
- [3]. S. Raza, H. Mokhlis, H. Arof, J. A. Laghari, and L. Wang, "Application of signal processing techniques for islanding detection of distributed generation in

- distribution network: A review,” *Energy Conversion and Management*, vol. 96, pp. 613-624, 2015.
- [4]. M. Khodaparastan, H. Vahedi, F. Khazaeli, and H. Oraee, “A novel hybrid islanding detection method for inverter-based DGs using SFS and ROCOF,” *IEEE Transactions on Power Delivery*, vol. 32, no. 5, pp. 2162- 2170, 2017.
- [5]. Virginia Tech. (2007). Consortium in energy restructuring: Introduction to DG and intentional islanding. [Online]. Available: <https://www.dg.history.vt.edu/ch3/islanding.html>.
- [6]. S. K. G. Manikonda and D. N. Gaonkar, “Comprehensive review of IDMs in DG systems,” *IET Smart Grid*, vol. 2, no. 1, pp. 11-24, 2019.
- [7]. C. R. Reddy and K. H. Reddy, “An efficient passive islanding detection method for integrated DG system with zero NDZ,” *International Journal of Renewable Energy Research*, vol. no. 4, pp. 1994-2002, 2018.
- [8]. K. Aziah, S. Hussain, B. Erdal, and K. Tamer, “A review of islanding detection techniques for renewable distributed generation systems,” *Renewable and Sustainable Energy Reviews*, vol. 28, pp. 483-493, 2013.
- [9]. P. Gupta, R. S. Bhatia, and D. K. Jain, “Average absolute frequency deviation value based active islanding detection technique,” *IEEE Transactions on Smart Grid*, vol. 6, no. 1, pp. 26-35, 2015.
- [10]. K. Min Sung, H. Raza, C. Gyu Jung, K. Chul Hwan, W. Chung Yuen, and C. Jong Seo, “Comprehensive review of islanding detection methods for distributed generation systems,” *Energies*, vol. 12, no. 5, pp. 837-857, 2019.
- [11]. H. Samet, F. Hashemi, and T. Ghanbari, “Minimum non detection zone for islanding detection using an optimal Artificial Neural Network algorithm based on PSO,” *Renewable and Sustainable Energy Reviews*, vol. 52, pp. 1-18, 2015.
- [12]. C. R. Reddy and K. H. Reddy, “Islanding detection techniques for grid integrated distributed generation- A review,” *International Journal of Renewable Energy Research*, vol. 9, no. 2, pp. 960-977, 2019.