

Grid Connected Hybrid Energy Storage Structure with Renewable Energy Sources

M.Tech. Scholar Amit Thakur

Department of Electrical & Electronics Engineering
NRI Institute of Information Science and Technology Bhopal
thakr.amit@gmail.com

Prof. Madhu Upadhyay

Head of the Department of Electrical & Electronics Engineering
NRI Institute of Information Science and Technology Bhopal
madyant44@gmail.com

Abstract – The structure of AC and DC systems needs to be modernized to meet consumer needs. When DC microgrid is associated with DC renewable energy and storage resources, it is highly praised for its high efficiency, stability, dependability or load contribution performance. The main objective of any DC microgrid is to provide a correct load power balance support on the allocate generator (DG) power supply. Due to the irregular nature of renewable energy, batteries play a main role in load stability between DC microgrids. Existing energy management strategies may be able to meet load demand. However, this technology is not applicable to rural power systems. This research provides an energy management strategy (EMS) for DC microgrids, using solar energy, wind power, super capacitors, and batteries as input sources for rural power. Conventional design methods take into account the nominal super capacitor voltage in the model and design of the controller. The conventional method of control construction can make the system unstable or introduce ringing in the DC bus voltage at the low capacity of the super capacitor. To this end, the sensitivity of the stability of the DC microgrid to the voltage change in the super capacitor is analyzed and a control design method is proposed to ensure the stability of the DC microgrid in all modes of operation. Design and stability analysis of DC microgrid with battery super capacitor storage system under variable supercapacitor operating voltage.

Keywords – DC Microgrid, EMS, Super capacitor, wind, diesel generator.

I. INTRODUCTION

The grid connected system is connected to a larger independent grid, usually the public grid and supplies energy directly into the grid. The supply of electrical energy in the grid requires a synchronous grid connected inverter (also called grid interactive inverter) to change direct current to other current. If there is a public electricity grid, the hybrid another energy system may be independent or grid linked. For independent applications, the system must have sufficient storage capacity to handle power changes from the alternative energy sources involved. This type of system can be considered a microgrid that has its own power generation and load. For grid connected applications, alternative microgrid energy sources can power local loads and the utility. In addition to active current, these DG sources can also be used to provide reactive current and voltage support for public electricity networks. If these systems are connected to the grid, the storage capacity of these systems may be less because the grid can be used as a backup of the system. However, when connected to a public power grid, system management strategies place important demands on operation and performance, such as voltage, frequency and harmonic rules.

Each morning, as you circle the sun, it absorbs light and heat. There are regions with different temperatures on the whole earth, so it is transferred from one region to another. These immediate variation help to generate wind: in warmer areas of earth, the air is warmer and consequently under high pressure, whiles the air under colder areas is under low pressure. Wind is movement of air from high pressure to low pressure. Wind turbines have been used for grain grinding, pumping and other mechanical applications for several years. There are now more than one million wind turbines in operation worldwide. Most of them are used for pumping water and generating electricity. Wind energy supplies a large amount of wind energy that has been used for milling grain, pumping and other mechanical power applications have been extended for years. However, the replacement of wind energy with a pollution-free power supply has sought to generate electricity from wind energy since the late 19th century. Since 1930, small battery charging technologies have been manufactured. Technology is constantly improving, both cheaply and reliably, so it can be expected that wind energy will be economically competitive in the next few decades.

Hybrid System: A hybrid system is a system that uses multiple sources of energy. The integration of systems

(wind and solar) has a greater impact on electricity generation. Such a system is called a "hybrid system".

The use of hybrid solar energy is realized in this field, where energy will be consumed throughout the year without any chance of interruption. There may be several energy combinations that meet the energy needs of hybrid power systems, solar and wind energy. The assignment is similar to the power from solar panels and wind turbines. The difference is that it is just an attachment in system.

Photovoltaic solar panels or small wind turbines deepen on weather conditions. so, solar or wind energy alone is not enough. If both wind and solar energy are included into a something new body, a lot of renewable energy specialist claim to have a satisfactory hybrid energy source. In summer, when the sun's rays are strong, the wind speed is comparatively small. In winter or sunny days are comparatively short, on the contrary, the wind speed is relatively high. The effectiveness of these renewable systems shows dissimilarity throughout the year. In other words, the two systems must support each other to maintain the permanence of energy production in the system.

Depending on the environmental conditions, the energy required by the system can be supplied separately from the wind or solar system, or both resources can be used simultaneously. The control unit determines which power source is used to charge the battery according to the input energy. Wind turbines first convert kinetic energy to mechanical energy and then convert it to electrical energy. The wind turbine in the system consists of a tower, an alternator, a frequency converter (gearbox) and a propeller. And pictures of the hybrid system built.

II. RELATED WORK

An effective DC microgrid control scheme can accurately divide the oscillation and DC component of the load current between distributed generation (DG) devices. The proposed control strategy includes current and voltage control blocks. The current control module includes an oscillating power sharing unit and a DC power sharing unit. The main idea of the proposed method is to distribute the oscillation and DC components into the core according to the power of the DG band by providing a suitable output impedance value and minimization. 'of the DG unit. Voltage control of volts is a set of multi-voltage control systems for controlling micro volumes. The detailed model of the proposed control proposal has been developed and the dynamics of the system architecture. As the integration of the local coordinator uses only the information of the corresponding DG unit, the design process is dispersed. As the trend of integrating DC renewable energy and DC loads into modern power sharing systems increases, DC microgrids are attracting more and more attention. Its high efficiency and simple control plan are another main

motivation for the development of DC microgrid architecture. It consists of a group of multi-distributed (DG) units connected to the end-user DC and AC loads through electronic power converters. The current oscillation component is introduced into the microgrid through the single-phase and / or direct current associated with the inverter.

3-phase unbalanced AC load. In addition, modern distributed power sources can combine DC and AC microgrids through interconnected converters (ICs) where any unbalanced load conditions in AC microgrids will produce fluctuating current components in DC microgrids. Therefore, the high permeability of single-phase and unbalanced three-phase inverters will introduce alternating current pulses twice as much as the primary frequency on the input side of the inverter. Integrating various AC loads into DC microgrids can cause potential power sharing problems. The oscillation current shared between the DG units depends on the line impedance value between DG and sources of protest.

Therefore, when it comes to the reduction of communication lines and the distribution of communication signals, the distance between the microgravity properties has a significant effect on the power distribution between the DG groups. This effect may force some DGs to provide higher wind speeds than others, resulting in power outages in some DGs.. This problem greatly reduces the capacity and reliability of the system, especially in the case where the DG unit cannot meet the upper limit of the total oscillation current demand. In addition, the current oscillation component generates a ripple of twice the fundamental frequency of the DC microgrid voltage

III. PROPOSED SYSTEM

The proposed DC microgrid includes four other sources (photovoltaic, wind, DG and battery). Photovoltaic power productions depend mainly on solar radiation and ambient temperature. The wind speed depends on the wind speed. PMSG is used to make electricity from turbines. Wind power is connected to DC microgrid via AC / DC converters to reduce voltage changes and all DG sources use inverters. Electricity generated by unconventional energy sources cannot continuously supply loads due to its intermittent nature.

Therefore, use batteries to ensure that there is no interruption in the supply of electricity to consumers. Using HESS to accurately model DC microgrids In traditional designs, the DC link voltage controller is designed by considering the nominal super capacitor voltage. Sensitivity examination of DC microgrid with super capacitor voltage changes Find the optimal super capacitor voltage to consider in the design so that the DC microgrid remains stable at all super capacitor operating voltages.

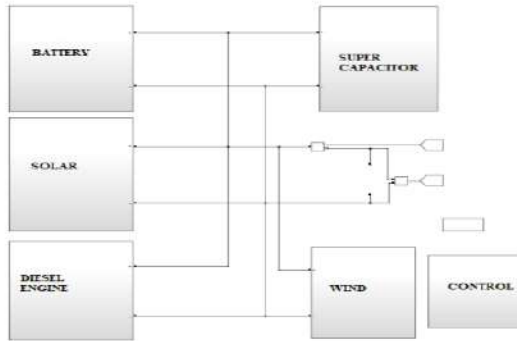

Fig .1 .proposed block diagram.

The control strategy proposed in this paper applies to the DC microgrid considered in this work. There are four possible modes of operation. This control strategy uses battery or photovoltaic power to regulate DC bus voltage in all four modes of operation. The four modes of operation are described below.

Battery Discharging Mode (BDM): In this mode, PV power is less than load and BatterySoC is within limits. Therefore, the battery is discharged to adjust the DC bus voltage.

Load Shedding Mode (LSM): In this mode, the PV current is less than the load and the battery is completely discharged. Therefore, the load is disconnected and the available power is used to charge the battery.

Battery Charging Mode (BCM): In this mode, PVpower is greater than the load and the battery's SoC is within limits. Therefore, the battery adjusts the DClink voltage by charging with available excess current.

PV Off-MPPT Mode (POM): In this mode, the battery is fully charged, so PV operates in non-MPPT mode to control the DC bus voltage. Under the operating conditions set by VSC0, the conventional and recommended DC microgrid output was analyzed at 112V, 32V and 12V for the above four operating modes.

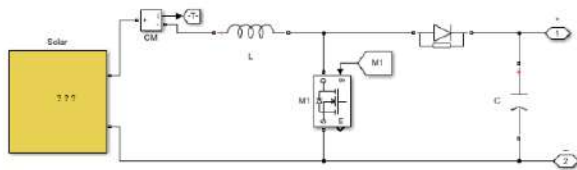

Fig. 2 .solar panel.

The inverter used in the grid-connected photovoltaic system is responsible for controlling DC bus voltage, grid-connected synchronization, and injecting high-quality electrical energy. The inverter used on the grid side of the present invention is called a voltage source converter (VSC) and is responsible for synchronizing the system voltage with the mains voltage. The mains voltage and frequency are used to operate the DC-AC inverter (inverter).

WIND TURBINE Doubly-fed electric machines are mostly electric machines that are fed ac currents into both

the stator and the rotor windings. Most doubly-fed electric machines in industry today are three-phase wound-rotor induction machines.

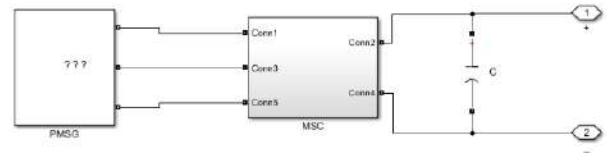

Fig.3 .wind turbine system .

DIESEL GENERATOR DG set (a unit of diesel engine and governor) is a device which converts fuel (diesel oil) energy into mechanical energy in diesel engine and subsequently converts mechanical energy into electrical energy in a governor.

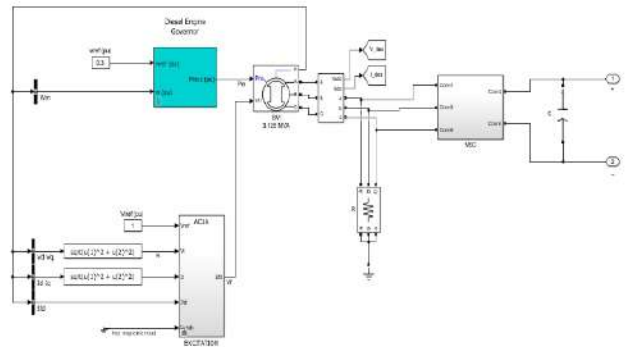

Fig.4 .Diesel Generator system.

BATTERY: A battery is a device consisting of one or more electrochemical cells with external connections provided to power electrical devices such as flashlights, mobile phones, and electric cars. When a battery is supplying electric power, its positive terminal is the cathode and its negative terminal is the anode. The terminal marked negative is the source of electrons that will flow through an external electric circuit to the positive terminal. When a battery is connected to an external electric load,

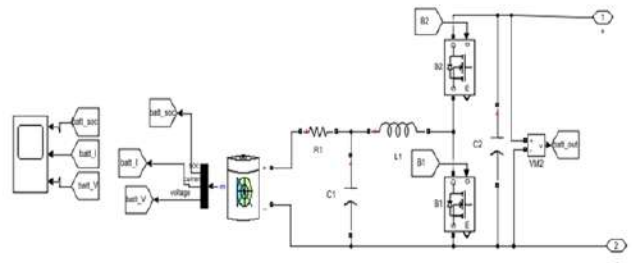

Fig.5. Battery Subsystem.

SUPER CAPACITOR: Super capacitors (or super capacitors) differ from ordinary capacitors in two important ways: their plates actually have a larger area, and the distance between them is much smaller because the separator between them Conventional dielectrics works differently.

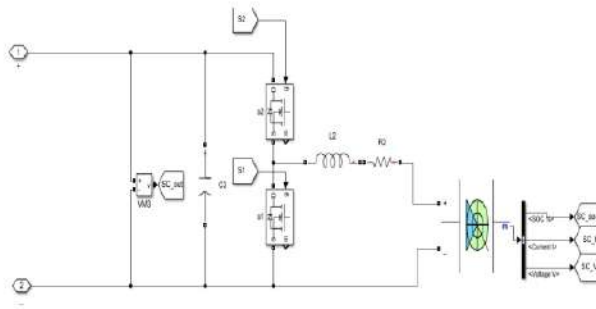

Fig.6. Super Capacitor.

MODE(i) Battery Discharging Mode (BDM): In this mode, the PV power is less than the load power and the battery SoC is within limits. Therefore, the battery discharges to regulate the DC link voltage.

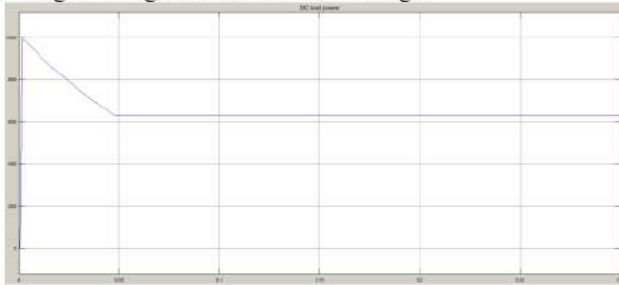

Fig.7. DC Load Power.

Fig.8 shows the diagram of PV cell where boost converter is connected across it. By the help of maximum power point tracker the photovoltaic cell generates the electrical power at the temperature of 25°C and irradiation level of 1000 W/m². This generated voltage of the PV system is boosted up or the voltage level of PV system. Analysis and Simulation of Photovoltaic System Connected to the Grid Using Matlab. The DC/DC converter or boost converter and again this increased voltage is applied to DC/AC converter or inverter. Here, the solar power is 600watts < load power is 630watts show in fig 8

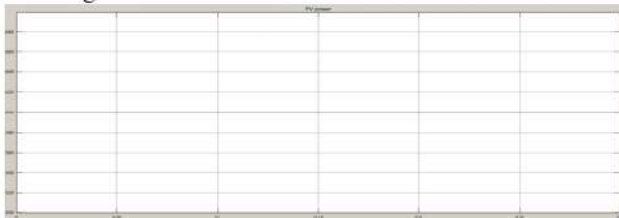

Fig. 8. Solar (PV) Power.

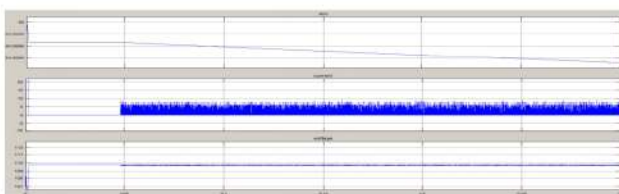

Fig. 9. Battery (SOC, Current, Voltage)

Here, the battery discharge to compensate the load power show in fig 9

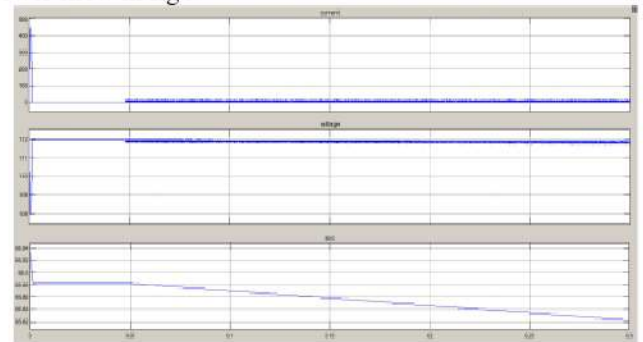

Fig .10 .Super Capacitor (Current, Voltage, SOC)

Here, the super capacitor is discharge to compensate the load power show in fig 10

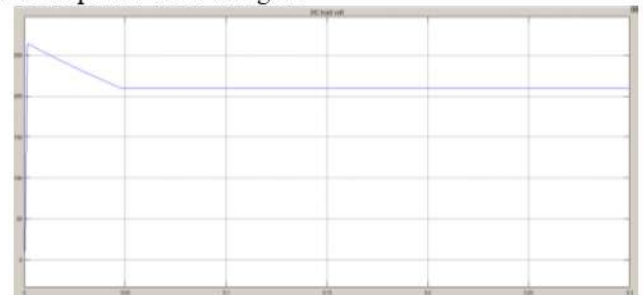

Fig .11. DC Load Voltage.

Here, the dc load voltage is maintain constant show in fig 11

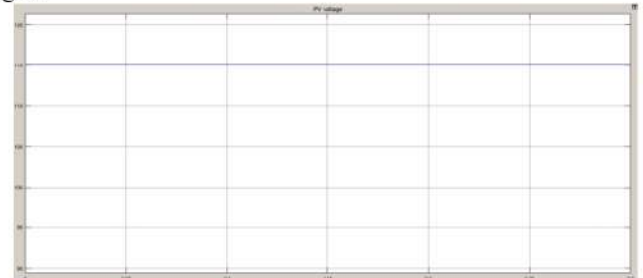

Fig.12. Solar(PV) Voltage .

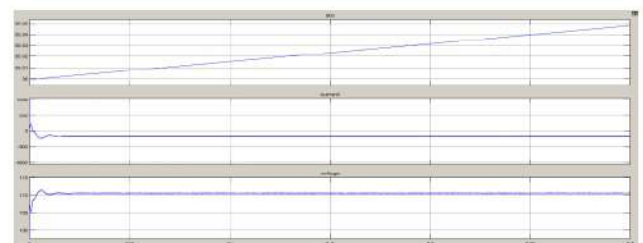

Fig. 13. Battery(Soc,Current,Voltage).

Here, the battery is discharged below the lower limit show in fig 13

Mode(ii) Load Shedding Mode (LSM): In this mode, the PV current is less than the load and the battery is completely discharged. Therefore, the load is disconnected and the available power is used to charge the battery.

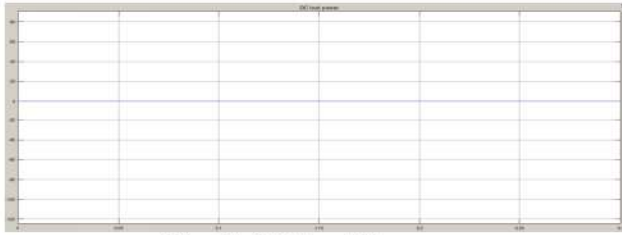

Fig. 14. DC Load Power.

Here, the load is disconnected to charge the battery show in fig 14

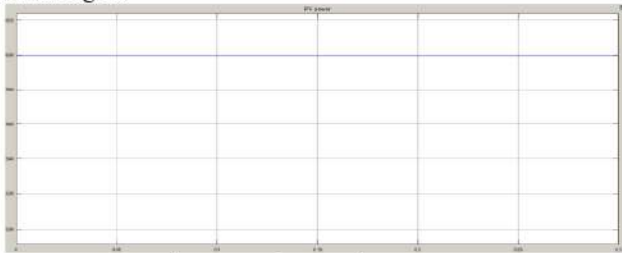

Fig. 15. Solar (PV) Power.

Here, the super capacitor also discharge to charge the battery The voltage (V_{sofc}) obtained from SOFC is increased by a DC / DC converter (boost converter). When the load demand is greater than the PV current, the boost voltage (V_{sofc_boost}) is used to meet the demand.

MODE(iii) Battery Charging Mode (BCM): In this mode, the PV current is greater than the load and the battery's SoC is within limits. Therefore, the battery adjusts the DC link voltage by charging with available excess current

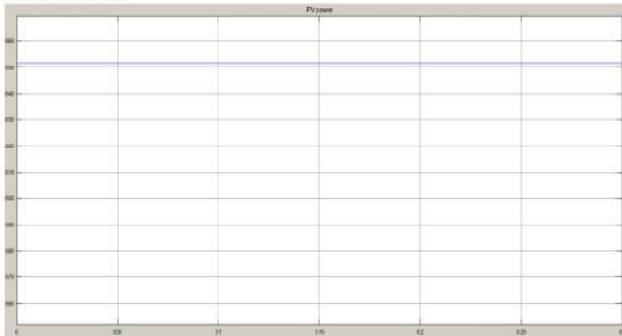

Fig. 16. Solar (PV) Power.

Here, the load power is 630 watts < solar is power 652 watts show in fig 16

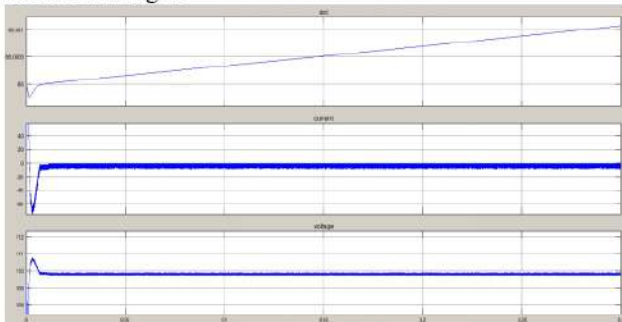

Fig. 17. Battery(SOC,Current,Voltage)

Here, the battery is charging show in fig 17

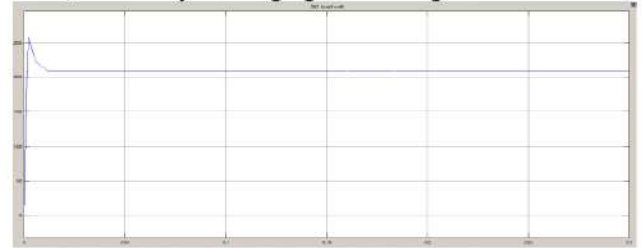

Fig. 18. DC Load Voltage.

Here, the load voltage is maintained constant 210volt. When the load is directly connected to the solar panel, the panel operating point rarely reaches the peak power. The impedance seen by the panel determines the solar panel's operating point. Therefore, by changing the impedance seen on the panel, the operating point can be moved to the maximum power point.

Mode(iv) PV Off-MPPT Mode (POM): In this mode, the battery has fully charged, therefore, the PV is operated in off-MPPT mode to regulate the DC bus voltage. MPPT is OFF show in fig 19

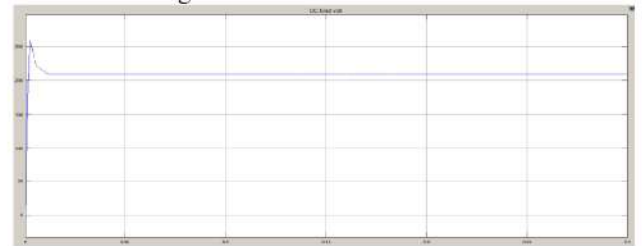

Fig.19. MPPT OUTPUT.

MPPT checks the output of the PV module, compares it with the battery voltage, and then determines the optimum power that the PV module can produce to charge the battery, then converts it to the optimum voltage to provide the maximum current to flow into the battery. . It can also turn on DC loads directly connected to the battery.

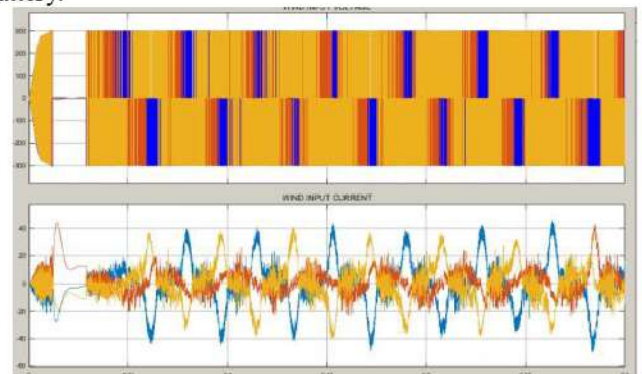

Fig. 20. wind output.

Output from a wind turbine depends on the size of the turbine and the wind speed through the rotor. An onshore wind turbine with an average capacity of 2.5–3 MW can generate more than 6 million kWh of electricity per year, enough to power 1,500 ordinary EU homes.

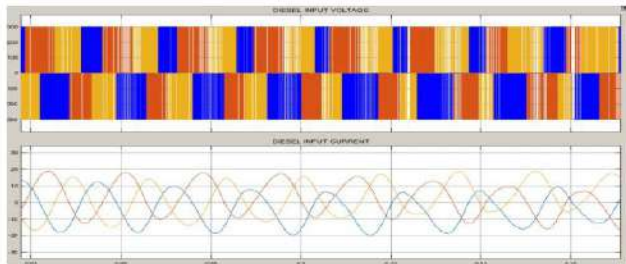

Fig.21. Diesel Input.

The generator can only emit limited power. The company uses watts to evaluate the generator's output. The power is calculated by multiplying the voltage by the amperage capacity of the electrical equipment (watts = volts x amps). The diesel generator converts mechanical energy (motion) into electrical energy and passes it through cables. The generator can be considered an "electric pump" that causes current to flow through wires

IV. CONCLUSION

Using its accurate small-signal model, the influence of supercapacitor voltage change on the stability of DC microgrid is analyzed. An optimal DC bus voltage controller design method based on supercapacitor voltage is proposed to ensure sufficient gain and phase margin at all supercapacitor voltages. Simulation and experimental results confirm that the proposed design has greater gain and phase margin compared to conventional design. Therefore, the proposed controller design can achieve excellent dynamic response over a wide range of supercapacitor operating voltages. In the proposed method, we tested it with batteries and supercapacitor, and we had to apply it impulsively to the grid system. The system can be used in all other renewable energy applications. Bidirectional inverters are used in energy management programs they are considered the input to solar energy. Batteries and supercapacitor and loads can be connected to the grid through inverters.

REFERENCES

- [1]. Jinsong Kang ; Hao Fang ; Lanying Yun A Control and Power Management Scheme for Photovoltaic/Fuel Cell/Hybrid Energy Storage DC Microgrid2019 14th IEEE Conference on Industrial Electronics and Applications (ICIEA) Year: 2019 ISBN: 978-1-5386-9490-9 DOI: 10.1109/IEEE Xi'an, China, China
- [2]. S Sheik Mohammed ; JM Krishnendu Energy Management Control of DC Microgrid with Electric Vehicle and Hybrid Energy Storage System 2019 2nd International Conference on Intelligent Computing, Instrumentation and Control Technologies (ICICT) Year: 2019 ISBN: 978-1-7281-0283-2 DOI: 10.1109/IEEE Kannur,Kerala, India, India
- [3]. Srikanth Kotra ; Mahesh K. Mishra Energy management of hybrid microgrid with hybrid energy storage system 2015 International Conference on Renewable Energy Research and Applications (ICRERA) Year: 2015 ISBN: 978-1-4799-9982-8 DOI: 10.1109/ IEEE Palermo, Italy
- [4]. Pinit Wongdet ; Boonruang Marungsri Hybrid Energy Storage System in Standalone DC Microgrid with Ramp Rate Limitation for Extending the Lifespan of Battery 2018 International Electrical Engineering Congress (iEECON) Year: 2018 ISBN: 978-1-5386-2317-6 DOI: 10.1109/ IEEE Krabi, Thailand, Thailand
- [5]. Li Jing ; ShenYanxia ; Wu Dinghui ; Zhao ZhipuA control strategy for islanded DC microgrid with battery/ultra-capacitor hybrid energy storage system 2016 Chinese Control and Decision Conference (CCDC) Year: 2016 ISBN: 978-1-4673-9714-8 DOI: 10.1109/IEEE Yinchuan, China
- [6]. Jinsong Kang ; Hao Fang ; Lanying Yun A Control and Power Management Scheme for Photovoltaic/Fuel Cell/Hybrid Energy Storage DC Microgrid2019 14th IEEE Conference on Industrial Electronics and Applications (ICIEA) Year: 2019 ISBN: 978-1-5386-9490-9 DOI: 10.1109/IEEE Xi'an, China, China
- [7]. S Sheik Mohammed ; JM Krishnendu Energy Management Control of DC Microgrid with Electric Vehicle and Hybrid Energy Storage System 2019 2nd International Conference on Intelligent Computing, Instrumentation and Control Technologies (ICICT) Year: 2019 ISBN: 978-1-7281-0283-2 DOI: 10.1109/IEEE Kannur,Kerala, India, India
- [8]. Srikanth Kotra ; Mahesh K. Mishra Energy management of hybrid microgrid with hybrid energy storage system 2015 International Conference on Renewable Energy Research and Applications (ICRERA) Year: 2015 ISBN: 978-1-4799-9982-8 DOI: 10.1109/ IEEE Palermo, Italy
- [9]. Pinit Wongdet ; BoonruangMarungsriHybrid Energy Storage System in Standalone DC Microgrid with Ramp Rate Limitation for Extending the Lifespan of Battery 2018 International Electrical Engineering Congress (iEECON) Year: 2018 ISBN: 978-1-5386-2317-6 DOI: 10.1109/ IEEE Krabi, Thailand, Thailand
- [10].Li Jing ; ShenYanxia ; Wu Dinghui ; Zhao ZhipuA control strategy for islanded DC microgrid with battery/ultra-capacitor hybrid energy storage system 2016 Chinese Control and Decision Conference (CCDC) Year: 2016 ISBN: 978-1-4673-9714-8 DOI: 10.1109/IEEE Yinchuan, China
- [11].B.T. Patterson, —DC, come home: DC microgrids and the birth of the Enernet,| IEEEPower Energy Magazine, 10, pp. 60–69, 2012.
- [12].D. Z. G.C. LazaroIU, —Improvements, A control system for dc arc furnaces for

- powerquality,|Electr. Power Syst. Res., vol. 80, no. 12, pp. 1498–1505, 2010.
- [13].Ahmed T. Elsayed, Ahmed A. Mohamed, and Osama A. Mohamed,, —DC microgrids and distribution systems: an overview,| Electr. Power Syst. Res., vol. 119, pp. 407–417,2015.
- [14].D. Chen and L. Xu, —Autonomous DC voltage control of a DC microgrid with multipleslack terminals,| IEEE Trans. Power Syst., vol. 27, no. 4, pp. 1897–1905, 2012.
- [15].[5] Z. W. Q. Zhong, L. Lin, and Y. Zhang, —Study on the Control Strategies and DynamicPerformance of DC Distribution Network,| in IEEE Power and Energy Society GeneralMeeting, pp. 1–5, 2012.
- [16].C. N. Papadimitriou, E. I. Zountouridou, and N. D. Hatziargyriou, —Review ofhierarchical control in DC microgrids,| Electr. Power Syst. Res., vol. 122, pp. 159–167,2015.
- [17].Zhihong Ye, D. Boroyevich, Kun Xing, F.C. Lee, —Design of parallel sources in DCdistributed power systems by using gain-scheduling technique,| in IEEE Annual PowerElectronics Specialists Conference, pp. 161–165, 1999.
- [18].Z. H. Jian, Z. Y. He, J. Jia, and Y. Xie, —A review of control strategies for DC microgrid,| Proc. Int. Conf. Intell. Control Inf. Process. ICICIP 2013, pp. 666–671, 2013.