

# A Proposed Modelling of a Nigeria Power System with Unified Power Flow Controller

Ananti John Egbunike, Nwana Obiora C

Department of Electrical Electronics Engineering

Federal Polytechnic Oko

Anambra State, Nigeria

E-mail : john.ananti@federalpolyoko.edu.ng

**Abstract** – The problem of power supply in most countries like Nigeria is the ability to maintain steady supply of electricity to every part of the country without first expanding the existing power network. This is achievable with the use of power electronic devices called Flexible alternating current transmission system (FACTS). This paper looked at one of the types of FACTS devices called unified power flow controller (UPFC). The unified power flow controller (UPFC) is a combination of two inverter based compensating device, the shunt compensating static compensator (STATCOM) and a series compensating static synchronous series compensator (SSSC). The combination of the two allows for control of power flow along with independent control of voltage. This paper presents the basis upon which the UPFC operates. It gave the circuit configurations of UPFC, the operating principles, the benefit of making use of UPFC in a power network, modeling of power system with UPFC and then concludes with the proposal on the placement of UPFC on the identified voltage violated areas of the 58 Bus Nigeria 330kv transmission Line network.

**Keywords** – FACTS, UPFC, STATCOM, SSSC, IPFC, Modeling

## I. INTRODUCTION

The unified power flow controller (UPFC) is a combination of two inverter based compensating device, the shunt compensating STATCOM and a series compensating SSSC. The combination of the two allows for control of power flow along with independent control of voltage. Control over the power flow is utilized to redirect power from overloaded parts of a transmission system to paths with unused capacity. The most widely used method of power flow control is through the use of phase shifting transformers (PST). A PST has a low control bandwidth and has a high maintenance/replacement requirement.

As the power flow volatility increases in the market, the need increases for full power flow control with a high bandwidth to be able to utilize the existing transmission system capacity. The UPFC fills this requirement but with a high system setup cost [18], A UPFC can perform as other FACTS devices, given, that it has sufficient capability for the situation it is to handle. From the UPFC, more advanced systems known as an interline power flow controller (IPFC) and a generalized unified power flow controller (GUPFC) can be derived.

The IPFC and GUPFC can control power flow in multiple transmission lines from the same substation. From the growing restriction on the construction of new power

lines, along with the increased volatility of power flow, power flow controllers such as the UPFC have been utilized [18]. The first UPFC installation went into operation on May 1, 1998 at the Inez power station in Kentucky [2].

## II. CONFIGURATION OF UPFC

A UPFC can perform as other FACTS devices, given, that it has sufficient capability for the situation it is to handle. From the UPFC, more advanced systems known as an interline power flow controller (IPFC) and a generalized unified power flow controller (GUPFC) can be derived [21]. The IPFC and UPFC can control power flow in multiple transmission lines from the same substation. From the growing restriction on the construction of new power lines, along with the increased volatility of power flow, power flow controllers such as the UPFC have been utilized [19]. The first UPFC installation went into operation on May 1, 1998 at the Inez power station in Kentucky [2].

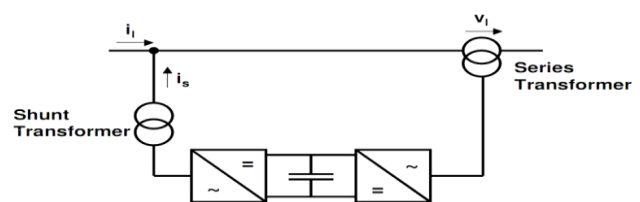

Figure 1. Principle configuration of an UPFC [19]

A UPFC is a configuration made up of a STATCOM combined with a SSSC. This combination allows for the both real and reactive power compensation simultaneously. The control is possible by injecting a voltage through a series transformer and a reactive current through a shunt transformer. The control voltage is controllable in both phase angle and magnitude and is added with the transmission line voltage [5]. The control current is also controllable in both phase angle and magnitude, and is delivered to or received from the transmission line as needed [12]. The series voltage and shunt current signals are supplied by their own voltage source converters. Both converters share a common DC link capacitor. The shunt converter is responsible for maintaining the voltage on the DC link capacitor so that the active power required by the series converter is available [7]

The DC link capacitor allows for the exchange between the two converters of active power. There is no reactive power that flows between the two converters, and therefore, are controlled independently by each. This gives three independently controllable parameters for the two UPFC buses that can be controlled at once. Voltage control is handled by the shunt converter, while control of the flow of active and reactive power is handled by the Series converter [1]. In practice, the series branch will need to be protected through the use of a thyristor bridge.

### III. BENEFITS OF USING A UPFC

The UPFC has the ability to provide several benefits simultaneously. The first would be local bus voltage regulation which comes from the shunt configuration [3]. The second would be power flow in a transmission line which comes from the series configuration.

These are the two control modes that are most notably utilized and studied in the analysis of a UPFC; however, the combination gives the benefits of controlling impedance, voltage angle, and power flow in the system. Additionally, the series aspect may gain the ability to provide direct voltage injection, phase angle shifting, and independent impedance control [19],[13], [12]. One benefit that a UPFC can provide that no other device before it could offer is that during an emergency, the series converter can control its voltage magnitude to provide voltage support on the other side of the UPFC connection [20]. Advancements in the modeling of the UPFC has led to 13 different control modes [19]:

- Active and reactive power flow control
- Power flow control by voltage shifting
- General Direct Voltage Injection
- Direct Voltage Injection with  $V_{se}$  in phase with  $V_i$
- Direct Voltage Injection with  $V_{se}$  in Quadrature with  $V_i$  (lead)

- Direct Voltage Injection with  $V_{se}$  in Quadrature with  $V_i$  (lag)
- Direct Voltage Injection with  $V_{se}$  in Quadrature with  $I_{if}$  (lead)
- Direct Voltage Injection with  $V_{se}$  in Quadrature with  $I_{if}$  (lag)
- Voltage Regulation with  $V_{se}$  in phase with  $V_i$
- Phase Shifting Regulation
- Phase shifting and Quadrature Regulation (lead)
- Phase shifting and Quadrature Regulation (lag)
- Line Impedance Compensation

### III. OPERATING PRINCIPLES OF A UPFC SYSTEM

A UPFC has the ability to control all of the fundamental power system parameters, to dynamically compensate the AC power requirements, compensate for reactive power through the shunt branch, compensate for real power through the series branch, and perform phase shifting either independently or in combination [9]. The power system parameters mentioned are the transmission voltage, impedance and phase angle.

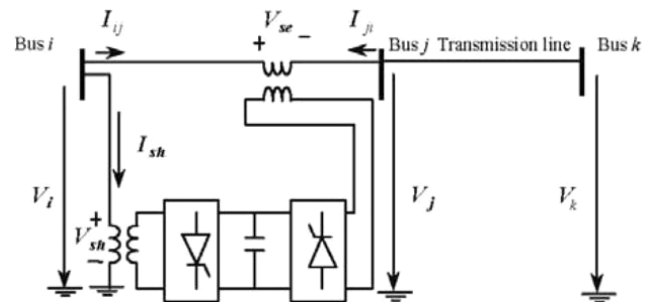

Figure 2 Operating principle of a UPFC [20]

Figure 2. depicts how a UPFC operates [19]. As can be seen, the series converter is coupled to the transmission line through a series transformer, while the shunt converter is coupled to a local bus designated through a shunt transformer. Both converters are connected through a common DC link capacitor. The shunt converter is the master converter, being able to both generate and absorb a controllable amount of reactive power, along with providing an active power exchange to the series converter, allowing it to perform as required [13]. By defining phasor quantities, an equivalent circuit of figure 2. can be obtained where

- $V_{sh}$  is the equivalent shunt voltage injected
- $V_{so}$  is the equivalent series voltage injected
- $Z_{sh}$  is the impedance of the shunt coupling transformer
- $Z_{so}$  is the impedance of the series coupling transformer
- $V_i$  is the voltage at bus  $i$
- $V_j$  is the voltage at bus  $j$

- $V_k$  is the voltage at bus  $k$  at the receiving end of the transmission line
- $I_{sh}$  is the current flowing through the shunt converter
- $Q_{sh}$  is the reactive power flowing through the shunt converter and leaving bus  $i$
- $P_{ij}$  is the UPFC series active power flowing out of bus  $j$  into  $i$
- $Q_{ij}$  is the UPFC series active power flowing out of bus  $j$  into  $i$
- $P_{sh}$  is the active power flowing between the shunt converter and the DC link capacitor and leaving bus  $i$
- $P_{so}$  is the active power flowing between the series converter and the DC link capacitor

No leakage current is assumed, so the current flowing from bus  $i$  to  $f$  is equal and opposite to the current flowing from bus  $f$  to  $i$  [14]:

$$I_{if} = -I_{fi} \quad (1)$$

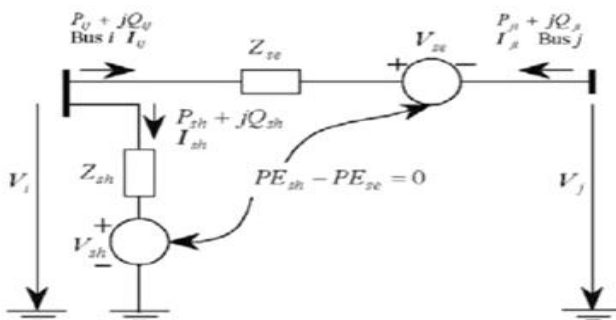

Figure 3 Equivalent circuit of a UPFC [14]

Referring to figure 3, the UPFC has been modeled and analyzed in the implementation of regulating voltage on bus  $i$  and Bus  $j$  controlling both active and reactive power flow in the transmission line linking bus  $i$  and bus  $j$ . These benefits are well defined and are equivalent to that of a combination STATCOM and SSSC that the UPFC is composed of. The UPFC provides additional control that the STATCOM and SSSC would not be able to provide independently such as shifting phase angles, voltage manipulations, and changing equivalent impedances. These parameters can be controlled independently or in combinations [20], [14].

#### IV. MODELING OF POWER SYSTEMS WITH UPFC

For the purpose of fundamental frequency steady-state analysis an equivalent circuit consisting of two coordinated synchronous voltage sources should represent the UPFC adequately. Such an equivalent circuit is shown in Figure 3. The synchronous voltage sources represent the fundamental Fourier series component of the switched

voltage waveforms at the AC converter terminals of the UPFC [6]

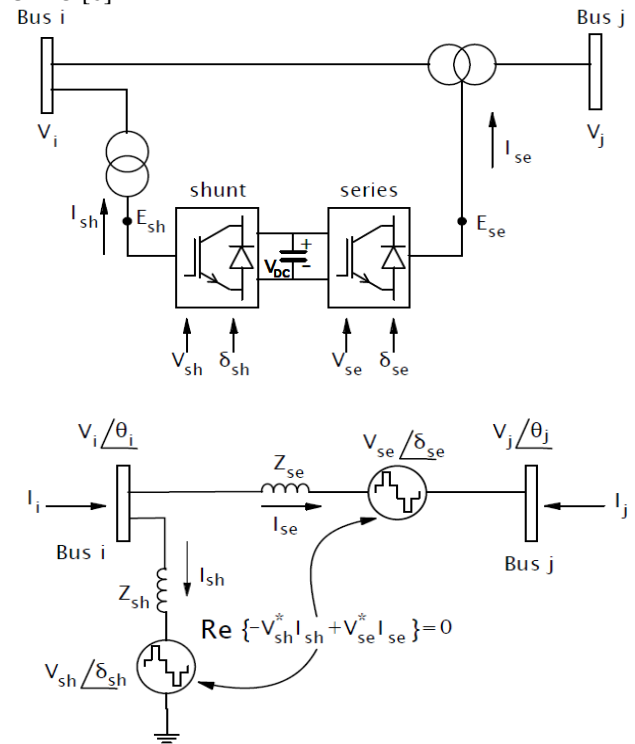

Figure 4 UPFC Equivalent Circuit. (a) UPFC schematic diagram; (b) UPC equivalent circuit

The UPFC voltage sources are:

$$E_{sh} = V_{sh} (\cos \delta_{sh} + j \sin \delta_{sh}) \quad (2)$$

$$E_{se} = V_{se} (\cos \delta_{se} + j \sin \delta_{se}) \quad (3)$$

Where  $V_{sh}$  and  $\delta_{sh}$  are the controllable magnitude ( $V_{sh(min)} \leq V_{sh} \leq V_{sh(max)}$ ) and phase angle ( $0 \leq \delta_{sh} \leq 2\pi$ ) of the voltage source representing the shunt converter.

The magnitude  $V_{se}$  and phase angle  $\delta_{se}$  of the voltage source representing the series converter are controlled between limits ( $V_{se(min)} \leq V_{se} \leq V_{se(max)}$ ) and ( $0 \leq \delta_{se} \leq 2\pi$ ), respectively.

If  $\delta_{se}$  is in phase with the nodal voltage angle  $\theta_i$ , the UPFC regulates the terminal voltage. If  $\delta_{se}$  is in quadrature with respect to  $\theta_i$ , it controls active power flow, acting as a phase shifter. If  $\delta_{se}$  is in quadrature with the line current angle then it controls active power flow, acting as a variable series compensator [10]. At any other value of  $\delta_{se}$ , the UPFC operates as a combination of voltage regulator, variable series compensator, and phase shifter. The magnitude of the series-injected voltage determines the amount of power flow to be controlled.

Based on the equivalent circuit shown in Figure 3.4 and Equations (2) and (3), the active and reactive power equations are at bus i[18]:

$$P_i = V_i^2 G_{ii} + V_i V_j [G_{ij} \cos(\theta_i - \theta_j) + B_{ij} \sin(\theta_i - \theta_j)] + V_i V_{se} [G_{ij} \cos(\theta_i - \delta_{se}) + B_{ij} \sin(\theta_i - \delta_{se})] + V_i V_{sh} [G_{sh} \cos(\theta_i - \delta_{sh}) + B_{sh} \sin(\theta_i - \delta_{sh})] \quad (4)$$

$$Q_i = V_i^2 B_{ii} + V_i V_j [G_{ij} \sin(\theta_i - \theta_j) + B_{ij} \cos(\theta_i - \theta_j)] + V_i V_{se} [G_{ij} \sin(\theta_i - \delta_{se}) + B_{ij} \cos(\theta_i - \delta_{se})] + V_i V_{sh} [G_{sh} \sin(\theta_i - \delta_{sh}) + B_{sh} \cos(\theta_i - \delta_{sh})] \quad (5)$$

At bus j:

$$P_j = V_j^2 G_{jj} + V_j V_i [G_{ji} \cos(\theta_j - \theta_i) + B_{ji} \sin(\theta_j - \theta_i)] + V_j V_{se} [G_{jj} \cos(\theta_j - \delta_{se}) + B_{jj} \sin(\theta_j - \delta_{se})] \quad (6)$$

$$Q_j = V_j^2 G_{jj} + V_j V_i [G_{ji} \sin(\theta_j - \theta_i) + B_{ji} \cos(\theta_j - \theta_i)] + V_j V_{se} [G_{jj} \sin(\theta_j - \delta_{se}) + B_{jj} \cos(\theta_j - \delta_{se})] \quad (7)$$

Series converter:

$$P_{se} = V_{se}^2 G_{jj} + V_{se} V_i [G_{ij} \cos(\delta_{se} - \theta_i) + B_{ij} \sin(\delta_{se} - \theta_i)] + V_{se} V_j [G_{jj} \cos(\delta_{se} - \theta_j) + B_{jj} \sin(\delta_{se} - \theta_j)] \quad (8)$$

$$Q_{se} = V_{se}^2 G_{jj} + V_{se} V_i [G_{ij} \sin(\delta_{se} - \theta_i) + B_{ij} \cos(\delta_{se} - \theta_i)] + V_{se} V_j [G_{jj} \sin(\delta_{se} - \theta_j) + B_{jj} \cos(\delta_{se} - \theta_j)] \quad (9)$$

Shunt converter:

$$P_{sh} = V_{sh}^2 G_{sh} + V_{sh} V_i [G_{sh} \cos(\delta_{sh} - \theta_i) + B_{sh} \sin(\delta_{sh} - \theta_i)] \quad (10)$$

$$Q_{sh} = V_{sh}^2 B_{sh} + V_{sh} V_i [G_{sh} \sin(\delta_{sh} - \theta_i) - B_{sh} \cos(\delta_{sh} - \theta_i)] \quad (11)$$

$$\begin{bmatrix} \Delta P_i \\ \Delta P_j \\ \Delta Q_i \\ \Delta Q_j \\ \Delta P_{ji} \\ \Delta Q_{ji} \\ \Delta P_{bb} \end{bmatrix} = \begin{bmatrix} \frac{\partial P_i}{\partial \theta_i} & \frac{\partial P_i}{\partial \theta_j} & \frac{\partial P_i}{\partial V_{sh}} V_{sh} & \frac{\partial P_i}{\partial V_j} V_j & \frac{\partial P_i}{\partial \delta_{se}} & \frac{\partial P_i}{\partial V_{se}} V_{se} & \frac{\partial P_i}{\partial V_{sh}} \\ \frac{\partial P_j}{\partial \theta_i} & \frac{\partial P_j}{\partial \theta_j} & 0 & \frac{\partial P_j}{\partial V_j} V_j & \frac{\partial P_j}{\partial \delta_{se}} & \frac{\partial P_j}{\partial V_{se}} V_{se} & 0 \\ \frac{\partial Q_i}{\partial \theta_i} & \frac{\partial Q_i}{\partial \theta_j} & \frac{\partial Q_i}{\partial V_{sh}} V_{sh} & \frac{\partial Q_i}{\partial V_j} V_j & \frac{\partial Q_i}{\partial \delta_{se}} & \frac{\partial Q_i}{\partial V_{se}} V_{se} & \frac{\partial Q_i}{\partial V_{sh}} \\ \frac{\partial Q_j}{\partial \theta_i} & \frac{\partial Q_j}{\partial \theta_j} & 0 & \frac{\partial Q_j}{\partial V_j} V_j & \frac{\partial Q_j}{\partial \delta_{se}} & \frac{\partial Q_j}{\partial V_{se}} V_{se} & 0 \\ \frac{\partial P_{ji}}{\partial \theta_i} & \frac{\partial P_{ji}}{\partial \theta_j} & 0 & \frac{\partial P_{ji}}{\partial V_j} V_j & \frac{\partial P_{ji}}{\partial \delta_{se}} & \frac{\partial P_{ji}}{\partial V_{se}} V_{se} & 0 \\ \frac{\partial Q_{ji}}{\partial \theta_i} & \frac{\partial Q_{ji}}{\partial \theta_j} & 0 & \frac{\partial Q_{ji}}{\partial V_j} V_j & \frac{\partial Q_{ji}}{\partial \delta_{se}} & \frac{\partial Q_{ji}}{\partial V_{se}} V_{se} & 0 \\ \frac{\partial P_{bb}}{\partial \theta_i} & \frac{\partial P_{bb}}{\partial \theta_j} & \frac{\partial P_{bb}}{\partial V_{sh}} V_{sh} & \frac{\partial P_{bb}}{\partial V_j} V_j & \frac{\partial P_{bb}}{\partial \delta_{se}} & \frac{\partial P_{bb}}{\partial V_{se}} V_{se} & \frac{\partial P_{bb}}{\partial V_{sh}} \end{bmatrix} \begin{bmatrix} \Delta \theta_i \\ \Delta \theta_j \\ \frac{\Delta V_i}{V_i} \\ \frac{\Delta V_j}{V_j} \\ \Delta \delta_{se} \\ \frac{\Delta V_{se}}{V_{se}} \\ \Delta \delta_{sh} \end{bmatrix}$$

## V.CONCLUSION

The power flow model for UPFC was derived and written in equation 12 and with this equation the same methods used in the next edition of this paper were used to calculate the bus voltages and phase angles, real and reactive power (both sides of each line), line loss and estimation of efficiency of the transmission line during the UPFC insertion in 58 bus Nigeria 330kv transmission line network. The search for the best placement of UPFC was done having known the positions of the violated buses.

The method is just to insert the UPFC FACTS device in the line bounded or adjacent to these violated buses. The best position is base on the degree of performance enhancement spread. Also researched on is the effect of variation of the parameters of UPFC FACTS device on the performance enhancement capabilities. This variation simulation was done in the best position in which the UPFC has the best of performance enhancement. The condition for the simulation of 58 bus Nigeria 330kV transmission network when inserted with UPFC is presented in section preceeding sections

## REFERENCES

- [1] Aswani, D. Clarke-Johnson,R. and Runyan,G (2015)“The Impact of Hydroelectric Power and Other Forms of Generation on Grid Frequency Stability for the WECC Region”, in Proc. AGC-Stability-Paper Conference, pp. 315, June 11.
- [2] American Electric Power(2015), "UPFC Installation," [Online]. Available: <http://www.aep.com/newsroom/newsreleases/?id=418>. [Accessed 04 -10 ].
- [3] Basu,M (2018)“ Optimal power flow with FACTS devices using differential evolution”, International Journal of Electrical Power & Energy Systems, Volume 30, Issue 2, February,9, Pages 150–156.
- [4] California Energy Commission(2014.), "Flexible AC Transmission Systems Benefits Study," Public Interest Energy Research, San Diego, CA, 2014.
- [5] Gupta, J.B (2005); A course in Power systems, Sanjeev Kumar Kataria & Sons, Naisarat Delhi.
- [6] Himgorani N. G. Gyugyi L., UnderstandingFACTS concepts and Technology of flexible AC transmission systems, new York. IEEE Press, 2000.
- [7] Lopez, and Alonso, L.(2013) “Modeling and Stability Analysis of Berlin Geothermal Power Plant in El Salvador”, Master’s Thesis, University of Iceland Reykjavik, pp. 3-56, April 4.
- [8] Math Works,(2017) "Three-Phase 48-Pulse GTO Converter," [Online]. Available: <http://www.mathworks.com/help/phymod/sps/examples/three-phase-48-pulse-gtoconverter.html>. [Accessed 20- 10 -17].
- [9] Mancor,N. Mahdad,B. Srairi,K. and Hamed,M (2015) “Multi Objective for Optimal Reactive Power Flow Using Modified PSO Considering TCSC”, International Journal of Energy Engineering, 2
- [10] Mustapha, M., Musa, B. U., & Bakura, M. U. M. (2015). Modelling Of Unified Power Flow Controller (Upfc) For The Control Of Real And Reactive Power Flow On 500 Kv Interconnected Power System. Studies, 8, 9.
- [11] Namin,M.H (2016)"Using UPFC in order to Power flow control," in Industrial Technology, 2006. ICIT 2016. IEEE International Conference on , Mumbai,.
- [12] Nijaz,D (2016) "Unified Power Flow Controller in Alleviation of Voltage Stability Problem," University of Zagreb, Zagreb,.
- [13] Peesari,V.(2016) "Study the Power Flow Control of a Power System with Unified Power Flow Controller," California State University, Sacramento, Sacramento, CA,.
- [14] Ravi,K. Shilaja,C. Babu,B.C and Kothari, D.P(2015) “Solving Optimal Power Flow Using Modified Bacterial Foraging Algorithm Considering FACTS Devices”, Journal of Power and Energy Engineering, Vol. 2, 639-64,
- [15] Ramesh,P. and Reddy,M.D(2013) Loss reduction through optimal placement of Unified Power-Flow Controller using Firefly Algorithm”, International Journal of Advanced Research in Electrical, Electronics and Instrumentation Engineering, Vol. 2, Issue 10, Oct. 13.
- [16] Shah,R ,Gandhi,S(2016) and Trivedi,B“Simulation and Performance Evaluation of UPFC and IPFC for Power System Performance Enhancement”, International Journal of engineering development and research, Vol.1 (2), Nov 10.
- [17] Sharma,N.K and Jagtap, P.P(2016) "Modelling and Application of Unified Power Flow Controller (UPFC)," in Emerging Trends in Engineering and Technology (ICETET), 2010 3rd International Conference on, Goa,.
- [18] Seifi, A., Gholami, S., & Shabanpour, A. (2010). Power Flow Study and Comparison of FACTS: Series (SSSC), Shunt (STATCOM), and Shunt-Series (UPFC). The Pacific Journal of Science and Technology, 11(1), 129-137.
- [19] Tareila,C.P (2015), "A single-phase D-STATCOM inverter for distributed energy sources," Kansas State University, Manhattan, KS
- [20] Zhang,X.P (2016), C. Rehtanz and B. Pal, Flexible AC Transmission Systems: Modelling
- [21] Zhao,B. Guo,C.X and Cao,Y.J (2015)“A multi agent-based particle swarm optimization approach for optimal reactive power dispatch,” IEEE Transactions on Power Systems 2015; Vol. 20: 1070-1078,
- [22] Vadhera,S.S (2014) Power System Analysis and Stability, (Khanna publishers), INDIA,.