

Parking System for Smart City using Internet of Thing

M.Tech. Student Monika Bijore
Department of Computer Science Engg
RKDF college of Engineering Bhopal, India
Bijore.monika@gmail.com

Asst. Prof. Monika Raghuwanshi
Department of Computer Science Engg,
RKDF college of Engineering Bhopal, India
Monipriya21@gmail.com

Abstract - Recently parking has become a serious issue and even worse, because of the increasing number of automobiles everywhere. In this paper we propose an IoT based guidance for user as well as Upcoming self-driving vehicles to search parking space for the vehicle. it also help user to choose the right vehicles to travel according to the parking spaces available to the destination point. it provides an intelligent guidance to the user, user can choose their travelling vehicle as two wheelers, four wheelers or public transport according to the traffic density. It aims to develop an intelligent parking guidance system, which reduces difficulty in conventional parking system. The system can monitor the state of every parking slot by deploying a sensor node on the slot. Accordingly, sensor senses the status of parking slot and sends status to central node server controller. The controller unit collects the data from all sensor node and upload to the server using http protocol where user can check the parking status from anywhere using internet and any browser. The system can also integrate with the artificial intelligence network like google assistance and self-driving car. Google assistance assist user to choose right vehicle according to the traffic density and parking space available at the destination point. User can simply see the space available by clicking in google map of their destination building or social parking.

Keywords - Ethernet Modem, Node MCU, Sensor node, Wi-Fi.

I. INTRODUCTION

In these days, main problem in market, marriage garden, malls and may more palace where peoples gather with their personal vehicles has parking issues. It is because of the insufficient parking space. Now a day the vehicles in a family are greater than the head count of the family members, and due to this the vehicles are also increased in the city, which leads to the parking scenario which is unhappily falling short to the current requirements in the city. Due to this parking is difficult and it also increases the time needed to park the vehicle with increase in the fuel consumption of the vehicle. And during the working days the companies and offices are facing the problem of the parking in urban areas.

Now a day's vehicles price is low, due to this four wheelers are most affordable to the low income group families, also the vehicles especially the four wheelers are taking lot of space. Due to the increase in vehicles the parking space is not sufficient in this congested cities, whether at a shopping malls, stations and airport, problems with parking is a big issue. Most of the time people spend their time on searching parking, to park their vehicles. Thus, lot of congestion occurs in the traffic which leads to a tedious job to find the parking space to park their vehicle. The most traffic occurs only because of vehicle congestion in the urban areas thus people are wasting time in searching the parking area abnormally to park their vehicles. And one more issue is

also added to this is pollution, which effects the entire environment due to this increase in vehicles.

II. RELATED WORK

Some of the recent studies demonstrate about the parking management and the parking slot management. It also gives the information about booking based parking system.

Chi-Hung Chuang, Luo-Wei Tsai [2]: - developed a checking system for parking lot managing system and the result of entree management is reduced humanoid resource, done the acknowledgement car license. The constraint of this project is the acknowledgement process takes more time to compare.

Mingkai Chen [3]: -developed a parking guidance and information system based on wireless sensor scheme and the data is transmitted between the nodes and processing the data, and the data passes to the display drivers. In this the restriction is, if the main node of the sensor scheme fails means the total chunk is failed.

Huang Cai-mei. [5]: - Accessible an idea for keeping the parking slots and reversed cars look for the intelligent stations to attain the parked location of vehicles and get the leader route, so that user can quickly discover the parking area.

Bhosale Swapnali [6]: - industrialized an idea for producing the multiple imageries using a fixed camera capture below dissimilar variations. Compound images detection & acknowledgement is important in the analysis of video data and higher level security system.

Vanessa W.S. Tang [8]: - presented an idea on WSN-based intelligent car parking system and the sensors are deployed into a car park field, with each parking lot equipped with one sensor node, which detects and screens the occupation of the space lot. The constraint of the project is that they deploy only sensor node if it fails means total lot info is losing.

Giuliano Benelli [9]: - grows an idea that the users use their own mobile phone for allows an electronic ticket to enter and exit the parking and as an electronic wallet to pay automatically for it.

III. PROPOSED WORK

Recently, with the short-tempered increase of automobiles in cities, parking difficulties are serious and even worsen in many cities.

The aim of the project is to design and provide: -

- A simple web application for parking vehicles.
- Live view of parking slot from home.
- Can search nearby places using google map.
- Easy embedding using API with other application.
- Parking owners can add their own parking palaces.
- Make easy to automate parking owners and customers.
- Reduces traffic congestion in the city.
- Reduces air and sound pollution.

User can search their destination parking facilities and according the availability they can choose vehicle either 4-wheeler, 2-wheeler or public transport to reach their destination. We have designed a simple web application. Where user can register their self and search for destination building or mart. User can also change their profile information's like name contact info. User can also add their identity card as driving licence.

User can also change their login password. On the other hand, any vehicle parking owner can create their profile and add their parking facilities. Like parking areas available and vehicle allow for parking. Owner has to add their parking location parking area name and name of building. Parking owners has to also add parking architecture. After than a team of parking installation goes to their parking location and installs the parking devises and sensors to their parking areas.

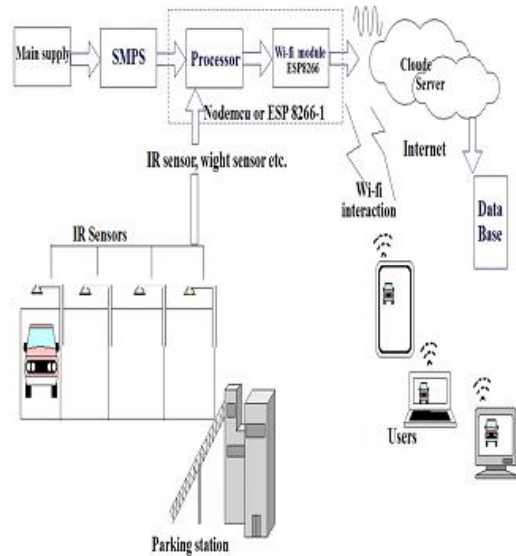

Fig.1. Proposed block diagram.

1. Implementation and Simulation

The implementation of the proposed system contains two different stages

- Software Implementation
- Hardware Implementation

1.1 Software Implementation

In the software implementation, we have designed a simple web application. Where user can register their self and search for building or area of their destination location.

1.2 Required things to deploy Web application.

1.2.1 Domain name:

Domain name is the most essential components for web application development.

“A domain name is an identification string that defines a realm of administrative autonomy, authority or control within the Internet”. Domain names are formed by the rules and procedures of the Domain Name System (DNS). Any name registered in the DNS is a domain name. Here we have used a free domain name along with the name of free domain name provider URL which is provided by 000webhostapp.com.

1.2.2 Server

“A computer or computer program which manages access to a centralized resource or service in a network”. Basically server computer is a centralised computer which has static IP that is mapped with the DNS server. The server computer always connected with high speed internet connection with static IP. Whenever any client device is request for any webpage using URL and web browser the server computer is responsible to manage the request and provide the related data.

Server computer also contain data base which is used to store the data of the user and also used to identify the

valid user info. In this project we have used server from 000webhostapp.com for testing purpose but according to the requirement we can take any server from any places on lease or we can setup own server. We have used following web development languages to develop our web application.

- HTML
- CSS
- Java Script
- PHP
- AJAX
- BOOTSTRAP
- SQL

1.3 Hardware Implementation

Every parking place has to install an IoT hardware kit. So that the IoT device update the status of that particular slot that is vacant of parked any car. The controller collects the sensor data and uploads to the server using API (application programming interface). The API is created on web server using PHP. Server receives the data using API and stores it in data base. Whenever any user search for the parking places the web application used that data to display the real result of the parking place.

IV. COMPONENTS REQUIRED

1. SMPS – SMPS (switch mode power supply) is the power source of the whole iot device.

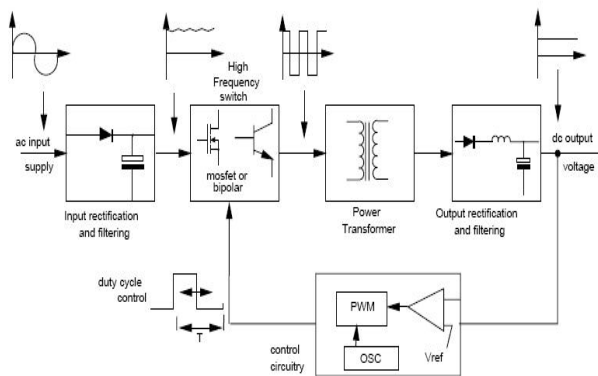

Fig.2. circuit diagram of switch mode power supply.

2. Wi-Fi Module: - in this project we have used Node MCU (Micro Controller Unit). The Node MCU contains Wi-Fi as well as a Node microcontroller. Node Microcontroller has 3Mb of ROM which can be used to upload a program.

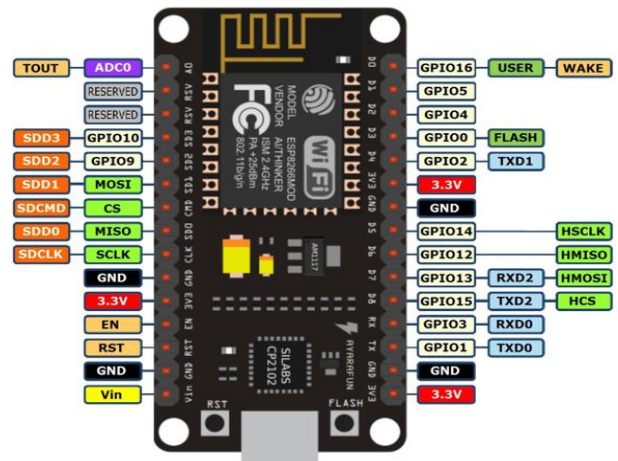

Fig.3. Pin Diagram of Node MCU.

ESP8266 is an impressive, low cost Wi-Fi module suitable for adding Wi-Fi functionality to an existing microcontroller project via a UART serial connection. The module can even be reprogrammed to act as a standalone Wi-Fi connected device—just add power! The feature list is impressive and includes:

- 802.11 b/g/n protocol
- Wi-Fi Direct (P2P), soft-AP
- Integrated TCP/IP protocol stack

The ESP8266 Wi-Fi Module is a self-contained SOC with integrated TCP/IP protocol stack that can give any microcontroller access to your Wi-Fi network. The ESP8266 is capable of either hosting an application or offloading all Wi-Fi networking functions from another application processor. Each ESP8266 module comes pre-programmed with an AT command set firmware, meaning, you can simply hook this up to your Arduino device and get about as much Wi-Fi-ability as a Wi-Fi Shield offers (and that's just out of the box)! The ESP8266 module is an extremely cost effective board with a huge, and ever growing, community.

This module has a powerful enough on-board processing and storage capability that allows it to be integrated with the sensors and other application specific devices through its GPIOs with minimal development up-front and minimal loading during runtime. Its high degree of on-chip integration allows for minimal external circuitry, including the front-end module, is designed to occupy minimal PCB area.

3. IR Sensor: -Infrared Obstacle Sensor Module has two part IR transmitter and IR receiver that sends out IR energy and looks for reflected IR energy to detect presence of any obstacle in front of the sensor module. The module has on board potentiometer that lets user adjust detection range. The sensor has very good and stable response even in ambient light or in complete darkness.

An IR sensor consists of an IR LED and an IR Photodiode; together they are called as Photo-Coupler or Opt-Coupler. As said before, the Infrared Obstacle Sensor has built-in IR transmitter and IR receiver. Infrared Transmitter is a light emitting diode (LED) which emits infrared radiations. Hence, they are called IR LED's. Even though an IR LED looks like a normal LED, the radiation emitted by it is invisible to the human eye. Infrared receivers are also called as infrared sensors as they detect the radiation from an IR transmitter. IR receivers come in the form of photodiodes and phototransistors. Infrared Photodiodes are different from normal photo diodes as they detect only infrared radiation. When the IR transmitter emits radiation, it reaches the object and some of the radiation reflects back to the IR receiver. Based on the intensity of the reception by the IR receiver, the output of the sensor is defined.

4. PCB Layout

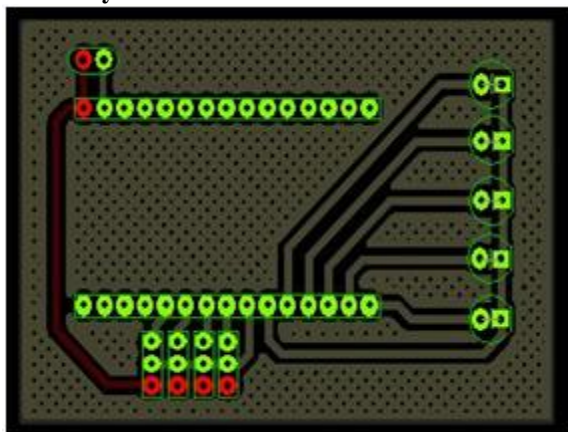

Fig.2. PCB Layout.

V. CONCLUSION

In this paper, we address the issue of parking and present an internet of things based web application smart parking system. The growth of Internet of Things have given rise to New possibilities in terms of smart cities. Smart parking Facilities and traffic management systems have always been at the core of constructing smart cities. The system that we propose provides real time information regarding availability of parking slots in a parking area. Users from any locations could book a parking slot for them by the use of our web application. The efforts made in this paper are indented to improve the parking facilities of a city and thereby aiming to enhance the quality of life of its people. In our system user can search and view the real view of parking area of any register buildings, mall, hospitals, colleges and may more public parking areas. Due to this user has a choice that in what transport system he should use to visit that place.

REFERENCES

- [1]. I.V.VAIBHAV, A.Ramya, A Review on Smart Parking Management System Using Vehicle Authentication, IJAREEIE 2016
- [2]. Chi-Hung Chuang, Luo-Wei Tsai, "Vehicle License plate recognition using super resolution technique", 2014 11th IEEE International Conference on Advanced Video and Signal Based Surveillance (AVSS).
- [3]. Mingkai Chen, "A Parking Guidance and Information System based on Wireless Sensor Network", IEEE International Conference on Information and Automation Shenzhen, China June 2011.
- [4]. Pahang, "Development of an Automatic Parallel Parking System for Nonholonomic Mobile Robot", International Conference on Electrical, Control and Computer Engineering Pahang, Malaysia, June 21-22, 2011.
- [5]. Huang Cai-mei, He Zhi-kun, "Design of Reverse Search Car System for Large Parking Lot Based on NFC Technology", 2014 IEEE.
- [6]. Bhosale Swapnali B, Kayastha Vijay S, "Feature extraction using surf algorithm for object recognition", International Journal of Technical Research and Applications.
- [7]. Face recognition using principal component analysis and neural networks, at: <http://www.researchgate.net/publication/23595016>
- [8]. W.S. Tang, Yuan Zheng, "An Intelligent Car Park Management System based on Wireless Sensor Networks", 2009 IEEE.
- [9]. Giuliano Benelli, Alessandro Pozzebon, "An Automated Payment System for Car Parks Based on Near Field Communication Technology", University of Siena, Italy be nelli,alessandro.pozzebon {@unisi.it}.
- [10]. Abhirup Khanna "IoT based Smart Parking System" University of Petroleum and Energy Studies (UPES) Dehradun, Uttarakhand, 2016.