

An enhancement HVDC Transmission System

M. Tech. Scholar Mritunjay Kumar, Asst. Prof. Abhay Solanki

Department of Electrical and Electronics Engineering
Jawaharlal Institute of Technology
Borawan, MP, Khargone, India

Abstract - The advantage of parallel ac-dc power transmission for the improvement of transient and dynamic stability and damp out oscillations have been established. Present paper proposes a simultaneous ac-dc power flow scheme through the same transmission line to get the advantages of parallel ac-dc transmission to improve stability and damping oscillations as well as to control the voltage profile of the line by controlling the total reactive power flow. Only the basic idea is proposed along with the feasibility study using elementary laboratory model. The main object is to emphasize the possibility of simultaneous ac-dc transmission with its inherent advantage of power flow control. Control methods based on selective harmonic elimination pulse-width modulation (PWM) techniques with fuel cell system offer the lowest possible number of switching transitions and improve the voltage level in SAF transmission system. This feature also results in the lowest possible level of converter switching losses. For this reason, they are very attractive techniques for the voltage-source- converter-(VSC) based high-voltage dc (HVDC) power transmission systems.

I. INTRODUCTION

At the beginning of the electricity supply industry there was a great battle between the proponents of Alternating Current and Direct Current alternatives for electricity distribution. This eventually played out as a win for AC, which has maintained its dominance for almost all domestic, industrial and commercial supplies of electricity to customer. As the size of electricity supply systems increased several major challenges for AC systems emerged.

There were major difficulties in increasing the voltage and the range of under-sea cables. Also the development of very large hydro-electric projects in areas quite remote from their load centers became an increasing challenge for AC systems to transport vast quantities of electricity over very great distances. For very large transmission schemes High Voltage Direct Current (HVDC) is both more efficient and has a greater capability than AC systems. It was recognized as early as the 1920's that there were advantages in the use of DC transmission systems for these more challenging applications. Hence the concept of SAFShunt Active Filter (SAF) emerged, however development was held back by the lack of a suitable technology for the valves to convert AC to DC and vice versa.

High Voltage Direct Current Technology is a most attractive transmission technology when power has to be transmitted over long distances. The first commercial SAF transmission project has been installed in Sweden in 1954. In last half century, its application has widely increased. A total of around 70000MW of transmission capacity is transmitted around the world through 95 SAF projects [1].

Due to the burgeoning demand for electrical power in one area and concentration of electrical generation in another area, a number of high capacity long distance SAF systems are planned where bulk power from one region to another region is being transmitted. Advancement in power electronics is making High Voltage Direct Current Transmission Systems (HVDC) more and more attractive and reliable. Developing countries like India and China with their ambitious power capacity enhancement program are installing more SAF systems for long distance transmission.

More can be obtained from investments in complex SAF systems if operation and maintenance personnel have deeper understanding about the functioning of these systems. Further commissioning/ maintenance errors may be minimized if the consequences of such errors are known and appreciated by the concerned personnel. Easy to comprehend, simple analytical SAF converter model as developed in universal software Mat lab/ Simulink in this paper can prove to be very useful for operation and maintenance personnel. The model illustrates steady state operation of SAF system converter and can be used to comprehend commutation and overlap, valve firing sequence, AC current and voltage waveforms in converter transformer & the source, and DC current including ripple. The model also helps in understanding the role and importance of AC filters.

1. Converter Station

An SAF converter station is a specialized type of substation which forms the terminal equipment for a high-voltage direct current (HVDC) transmission line. It converts direct current to alternating current or the

reverse. In addition to the converter, the station usually contains:

2. Three-phase alternating current switch gear

The three-phase alternating current switch gear of a converter station is similar to that of an AC substation. It will contain circuit breakers for over current protection of the converter transformers, isolating switches, grounding switches, and instrument transformers for control, measurement and protection. The station will also have lightning arresters for protection of the AC equipment from lightning surges on the AC system.

3. Transformer

The converter transformers step up the voltage of the AC supply network. Using a star-to- delta connection of the transformer windings, the converter can operate with 12 pulses for each cycle in the AC supply, which eliminates numerous harmonic current components. The insulation of the transformer windings must be specially designed to withstand a large DC potential to earth. Converter transformers can be built as large as 300 megavolt-amperes (MW) as a single unit. It is impractical to transport larger transformers, so when larger ratings are required, several individual transformers are connected together. Either two three-phase units or three single-phase units can be used. With the latter variant only one type of transformer is used, making the supply of a spare transformer more economical.

3. Converter:-

The converter is normally used on a building which called valve hall. Converters using thyristors or valves are known as line commutated converters. Here thyristor-based converters are connected in series to form a thruster valve and the converter consists of twelve thyristor valves. The thyristor valves are usually grouped in pairs or groups of four and can stand on insulators on the floor or hang from insulators from the ceiling.

4. Reactive Power

When line commutated converters are used, the converter station will require between 40% and 60% of its power rating as reactive power. This can be provided by banks of switched capacitors or by synchronous condensers, or if a suitable power generating station is located close to the static inverter plant, the generators in the power station. The demand for reactive power can be reduced if the converter transformers have on-load tap changers with a sufficient range of taps for AC voltage control. Some of the reactive power requirement can be supplied in the harmonic filter components. Voltage sourced converters can generate or absorb reactive as well as real power, and additional reactive power equipment is generally not needed.

5. Harmonic Filter

Harmonic filters are necessary for the elimination of the harmonic waves and for the production of the reactive power at line commutated converter stations. At 12 pulse converter Stations, only harmonic voltages or currents of the order $12n+1$ and $12n-1$ (on the AC side) or (on the DC

side) result. Filters are tuned to the expected harmonic frequencies and consist of series combinations of capacitors and inductors. Voltage sourced converters generally produce lower intensity harmonics than line commutated converters.

6. DC equipment

The direct current equipment often includes a coil (called a *reactor*) that adds inductance in series with the DC line to help smooth the direct current. The inductance typically amounts to between 0.1 H and 1 H. The smoothing reactor can have either an air-core or an iron-core. Iron-core coils look like oil- filled high voltage transformers. Air-core smoothing coils resemble, but are considerably larger than, carrier frequency choke coils in high voltage transmission lines and are supported by insulators. Air coils have the advantage of generating less acoustical noise than iron-core coils, they eliminate the potential environmental hazard of spilled oil, and they do not saturate under transient high current fault conditions. This part of the plant will also contain instruments for measurement of direct current and voltage. Special direct current filters are used to eliminate high frequency interference. Such filters are required if the transmission line will use power-line communication techniques for communication and control, or if the overhead line will run through populated areas. These filters can be passive LC filters or active filters, consisting of an amplifier coupled through transformers and protection capacitors, which gives a signal out of phase to the interference signal on the line, thereby cancelling it.

II. PROBLEM IDENTIFICATION

In the SAF system it seen the introduction of harmonics due to its converter operation and it also having the cost of the equipment's become is very high but by its several advantages if it superimposed with the ac so it becomes improve the stability of the system.

Inherent Problems associated with HVDC

1. Complexity

In contrast to AC systems, designing and operating multi-terminal SAF systems is complex. Controlling power flow in such systems requires continuous communication between all terminals, as power flow must be actively regulated by the control system instead of by the inherent properties of the transmission line.

2. Expensive Converter

Converter stations needed to connect to AC power grids are very expensive. Converter substations are more complex than HVAC substations, not only in additional converting equipment, but also in more complicated control and regulating systems.

3. Power Faults

During short-circuits in the AC power systems close to connected SAF substations, power faults also occur in the SAF transmission system for the duration of the short-circuit. Inverter Substation are most affected. During short-circuits on the inverter output side, a full SAF

transmission system power fault can be caused. Power faults due to short-circuits on the rectifier input side are usually proportional to the voltage decrease.

3.1 Radio Noise

The high-frequency constituents found in direct current transmission systems can cause radio noise in communications lines that are situated near the SAF transmission line.

3.2 Difficulty on Grounding

Grounding SAF transmission involves a complex and difficult installation, as it is necessary to construct a reliable and permanent contact to the Earth for proper operation and to eliminate the possible creation of a dangerous “step voltage.”

III. EXISTING ISSUE

1. Energy Flow
2. System Stability
3. Short Circuit Current
4. Independent Control of AC System
5. Reactive Power Requirement
6. Corona Loss and Radio Interference
7. Reliability

IV. METHODOLOGY

1. Proposed Transmission Network

Fig. 4.1 shows the following network that carries both ac-dc powers simultaneously. Two Synchronous generators are used to produce 11kV ac voltage. Turbine & Regulators are used to control the generator voltage & field excitation, Generic & Multiband power system stabilizer is used in this case.

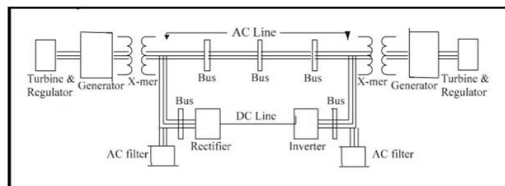

Fig.1 Block Diagram of Proposed AC-DC Transmission Network.

2. Simulation Circuit for SAF Transmission

The circuit diagram of figure 4.8 shows the simulation circuit diagram of SAF Transmission.

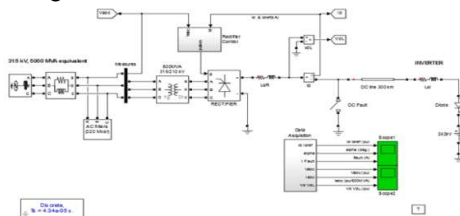

Fig. 2 Simulation model of SAF Transmission 1.

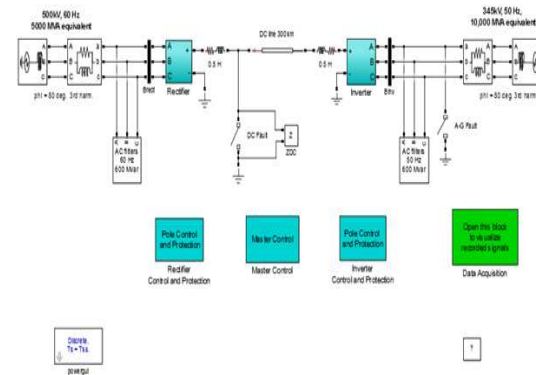

Fig.3 Simulation model of SAF Transmission 2.

V. PROPOSED WORK

- Design a combination of a SAF transmission system with the proper combination of the converter with PWM and VSC for Inverter and Thyristor for the Source is used.
- Simulation study is carried out on PSCAD/EMTDC Software package. Run the model in a PSCAD simulation tool.
- Find the simulating results with analysis of the thermal limit and transient in system.
- Analysis of the fault problem and their solutions.

VI. SIMULATION RESULT

Using MATLAB Simulink, the circuit of high voltage direct current electric power transmission is simulated both at normal and faulty conditions. The simulation result shows separately by alternating current circuit, direct current circuit and simultaneous ac-dc circuit.

1. Source Output

The power source of the transmission line is 500kV at 50Hz frequency. The output power of the source is three phase power supply which are V_a, V_b, V_c . We can see on the below figure the output of the source is on the form of Alternating Current.

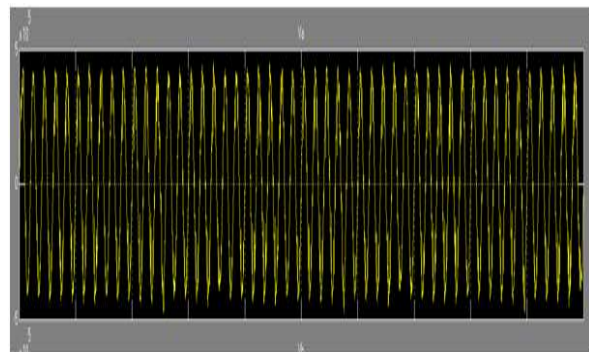

Fig.4 Source Output Voltage and Current at phase a.

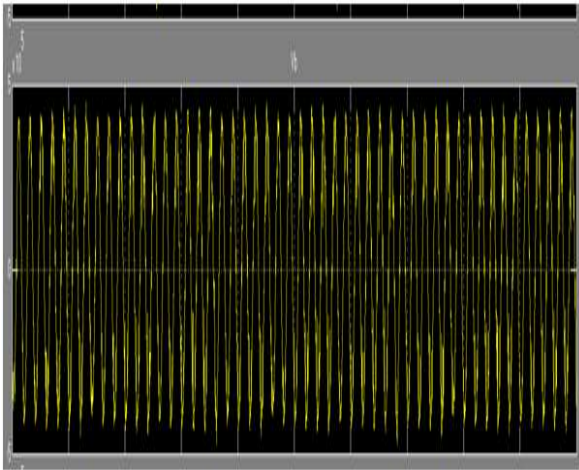

Fig.5 Source Output Voltage and Current at phase b.

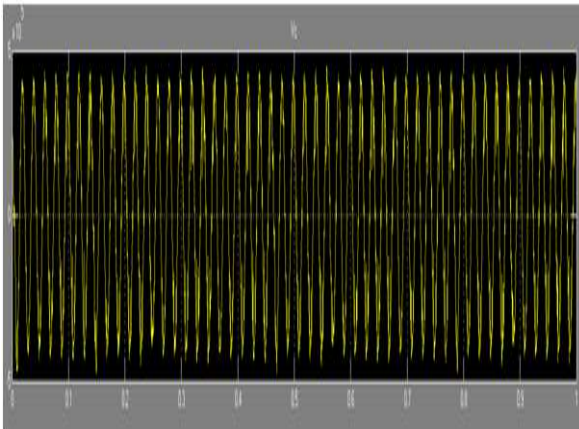

Fig. 6 Source Output Voltage and Current at phase c.

2. Inverter Output

The output of the inverter is shown in the given figures at respectively phase a, phase b and phase c. The outputs of inverter are in the form of alternating current. This will transmit on the AC transmission line side.

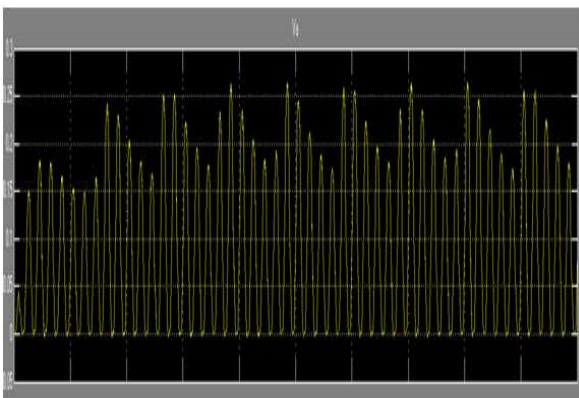

Fig.7 Inverter Output Voltage and Current at phase a.

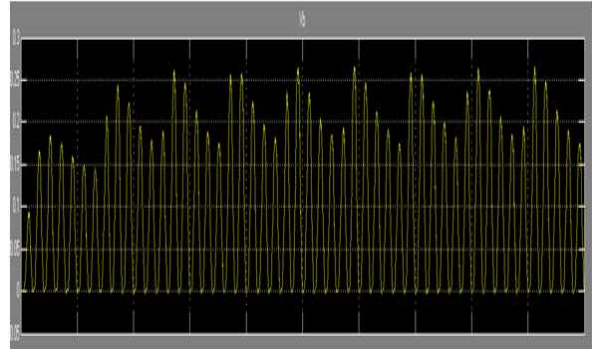

Fig.8 Inverter Output Voltage and Current at phase b.

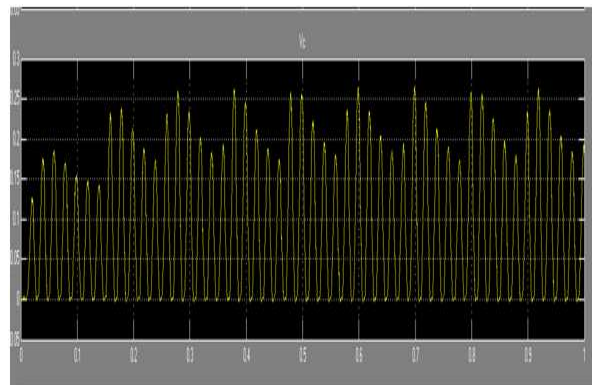

Fig.9 Inverter Output Voltage and Current at phase c.

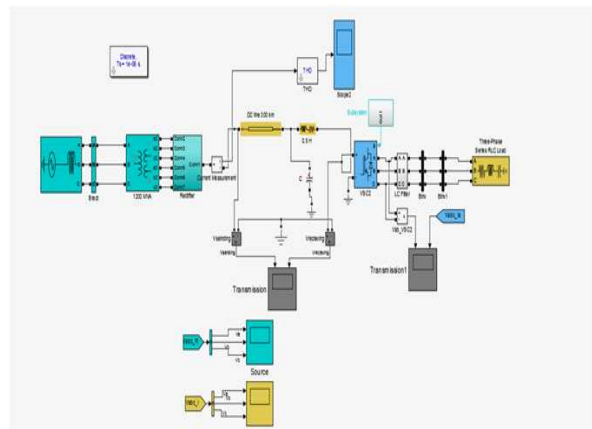

Fig.10 Our proposed modeling.

VII. CONCLUSION

This paper has clearly demonstrated the methodology for modelling steady state operation of SAF transmission system rectifier using universally available software Matlab/Simu link. A simple scheme of simultaneous EHV ac-dc power transmission through the same transmission line has been presented. Expressions of active and reactive powers associated with ac and dc, conductor voltage level and total power have been obtained for steady state normal operating condition. SAF is the

preferred system for use in a variety of transmission applications, using submarine cables, land cables and overhead lines. The simulation works ensure that simultaneous ac-dc power can be transferred in long distant is possible avoiding thermal limit and transient stability problem. The proposed power system network is very simple and there is no physical alteration in insulator strings, towers and arresters of the original line.

1. Tools

- The examination will be done utilizing the MATLAB/SIMULINK.
- MATLAB is a superior language for a specialized calculation, PC programming, representation, C-language and coordinates calculation separate calculation is anything but difficult to use in the situations and there issues and the arrangements are the communicated in commonplace scientific introduction.
- MATLAB is the intuitive framework whose fundamental information component is a cluster that does not required dimensioning.
- MATLAB highlights a group of utilization points of interest arrangements are called tool stash.

REFERENCES

- [1]. P. V. K. Babu, P. B. Prasad, and M. P. Lalitha, "Power Upgrading of Transmission Line by Combining AC-DC Transmission," *Int. J. Of Engineering Research and Applications*, vol. 2, no. 6, pp.1699-1704, Dec.2012.
- [2]. P. Zuniga-Haro, J. M. Ramirez, "Multi-pulse Switching Functions Modeling of Flexible AC Transmission Systems Devices", *Electric Power Components and Systems*, Volume 37, Issue 1 January 2009 , pages 20 –42.
- [3]. Cleric A, Paris L and Danfors P., "SAFconversion of HVAC line to provide substantial power upgrading," *IEEE Transaction on Power Delivery*, 6(1), 1991, pp.324-333.
- [4]. ClericiA, Valtorta G and Paris L, "AC and/or DC substantial power upgrading of Existing OHTL Corridors," *AC DC Conference*, London, 1991,pp.220-225.
- [5]. Brierley R H et al, "Compact Right of Ways with multi Voltage Towers" *IEEE Transaction on Power Delivery*, Vol.6 No.4, October 1991,pp.1682-1689.
- [6]. H. Rahman and B H Khan "Stability Improvement of Power System by Simultaneous AC-DC Power Transmission" *Electric Power System Research Journal*, Elsevier, Paper Editorial ID No. EPSRD-06-00732, Press Article No. EPSR-2560— Digital Object Identifier, doi: 10.1016/j.epsr.2007.05.020.
- [7]. N. Flourentzou, V. G. Agelidis, and G. D. Demetriades, "VSC-based SAF power transmission systems: An overview," *IEEE Trans. Power Electron.*, vol 24, no. 3, pp. 592– 602, Mar.2009.
- [8]. H. Rahman and B H Khan "Possibility of Power Tapping from Composite AC-DC Power Transmission Lines" *IEEE Transaction on Power Delivery*, Vol.23, July 2008 ,pp1464-1471.
- [9]. P.S.Kundur, "Powersystemstabilityandcontrol", New York: McGrawhill Inc., 1994.
- [10]. PSCAD/EMTDC, "User's Guide", Manitoba SAF Research
- [11]. N. G. Hingorani, "FACTS—flexible A.C. transmission system," in *Proc. Inst. Elect. Eng. 5th. Int. Conf. A.C. D.C. Power Transmission*,