

Integrated Solid Waste Management System For Power Generation And Agricultural Usage

¹Dr.K.N.Kazi, ²Phule Pragati Bhagwan, ³Kashid Mukta Rajendra, ⁴Rajmane Prajkta Pandurang

Department Of Electrical Engineering,
S. B. Patil College Of Engineering,Indapur

Abstract- — An Integrated Solid Waste Management System for Power Generation and Agricultural Usage is a sustainable approach to manage waste effectively while producing useful outputs. The system focuses on collecting, segregating, and processing different types of solid waste such as organic, recyclable, and non-recyclable materials. This system helps in reducing environmental pollution, minimizing landfill usage, and promoting energy generation. It also supports farmers by providing low-cost organic manure, improving soil fertility and crop yield. By integrating waste management with energy production and agriculture, the project contributes to sustainable development and efficient resource utilization. Overall, the system offers an eco-friendly, cost-effective, and practical solution to address waste disposal problems while generating power and supporting agricultural activities.

Index Terms:- Integrated Solid Waste Management (ISWM); Waste to Energy; Sustainable Agriculture; Energy Efficiency.

I. INTRODUCTION

The rapid growth of population, urbanization, and industrialization has led to a dramatic increase in municipal solid waste (MSW) generation worldwide. Conventional methods of waste disposal, such as open dumping and uncontrolled landfilling, not only consume valuable land resources but also cause severe environmental pollution, groundwater contamination, and greenhouse gas emissions. These challenges demand a sustainable and efficient approach to waste management.

An Integrated Solid Waste Management (ISWM) system provides a comprehensive framework for handling solid waste through systematic segregation, collection, processing, recycling, energy recovery, and safe disposal. In this project, the focus is on utilizing the biodegradable fraction of waste for renewable power generation through anaerobic digestion, producing biogas as a clean energy source. The biogas can be used to generate electricity for various applications, including powering agricultural water pumps, thereby reducing dependence on conventional fossil fuels.

Additionally, the digestion process yields nutrient-rich slurry, which can be utilized as organic manure, enhancing soil fertility and reducing the use of chemical fertilizers. This integrated approach not only minimizes the environmental footprint of waste but also contributes to sustainable agriculture, energy security, and the circular economy by converting waste into a valuable resource.

II. OBJECTIVE

- Promote Waste Segregation: Ensure Proper Separation Of Wet, Dry, And Inert Waste At The Source For Effective Processing.
- Produce Organic Fertilizer: Utilize Digestate/Compost To Create Nutrient-Rich Manure That Enhances Soil Fertility And Supports Sustainable Farming.
- Reduce Landfill Burden: Minimize The Volume Of Waste Sent To Landfills, Lowering Methane Emissions And Land Pollution.
- Encourage Resource Recovery: Recover Energy, Compost, And Recyclables To Support A Circular Economy.
- Support Farmers: Provide Affordable Energy And Bio-Fertilizers To Boost Agricultural Productivity And Reduce Dependency On Chemical Inputs.
- Protect Environment: Lower Greenhouse Gas Emissions, Reduce Groundwater Contamination, And Improve Overall Sanitation.
- Promote Community Participation: Involve Local Stakeholders And Raise Awareness For Long-Term Success Of The System.
- Achieve Economic Viability: Create Jobs, Generate Revenue From Energy And Compost Sales, And Ensure Financial Sustainability.

III. FEATURES OF TEG

- Integrated Approach: Combines waste collection, segregation, processing, and reuse in a single system.
- Agricultural Support: Supplies organic compost or digestate as a bio-fertilizer to improve soil fertility.
- Resource Recovery: Maximizes recycling of plastics, metals, paper, and converts dry waste into RDF/fuel.
- Pollution Control: Reduces landfill dumping, leachate, foul odour, and greenhouse gas emissions.
- Scalability: Can be implemented at household, community, or city level depending on available waste quantity.
- Cost-Effective Solution: Reduces energy and fertilizer costs for farmers and municipalities.
- Eco-Friendly: Promotes circular economy and supports sustainable development goals (SDGs).
- Employment Generation: Creates local jobs in waste collection, sorting, composting, and energy plant operations.
- Technology Flexibility: Allows combination of anaerobic digestion, composting, gasification, pyrolysis as per waste composition.

IV. CONCEPT AND METHODOLOGY

A. Block Diagram:

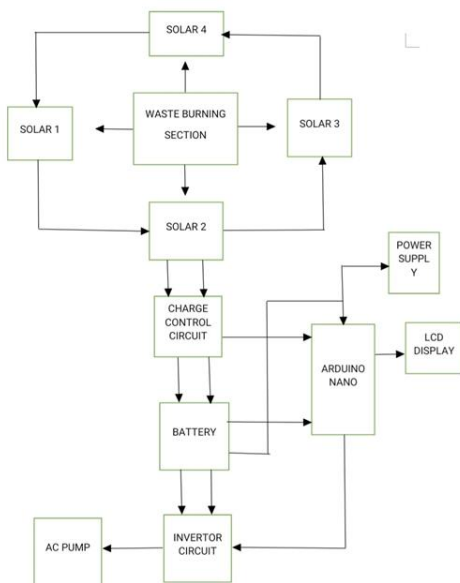

Fig: Electricity Generation From Waste Material

B. Description of the system

1. Solar Panels (Solar-1, Solar-2, Solar-3, Solar-4):

Multiple solar panels are used to capture solar energy.

Solar-1 & Solar-3: Supply direct power to the waste burning section, ensuring continuous heat for burning operations.

Solar-4: Supports the waste burning process and helps maintain energy balance.

Solar-2: Directly feeds into the charge control circuit to manage battery charging.

2. Waste Burning Section:

Waste materials are burned in this section to produce heat/energy. The energy may be used to generate additional electricity (through a thermoelectric generator or steam turbine setup) or assist in maintaining battery charge.

3. Charge Control Circuit:

This circuit regulates the charging of batteries to prevent overcharging or deep discharging, ensuring battery health and stable operation.

4. Battery Bank:

Stores the energy generated from solar panels and waste burning. This stored energy acts as a backup power source for periods without sunlight or waste input.

5. Arduino Nano + LCD Display:

The Arduino Nano is the microcontroller that monitors system parameters like battery voltage, current, power generated, and power consumed. The LCD display shows real-time status for user awareness.

6. Inverter Circuit:

Converts stored DC power from the batteries into AC power, making it suitable for operating the AC water pump.

7. AC Pump:

The final load that is powered by this system. It is used for pumping water for irrigation purposes.

8. Power Supply for Control System:

Provides stable power to the Arduino Nano and control circuitry for smooth system operation.

V. EXPERIMENTAL SETUP



Fig. Experimental setup

VI. CIRCUIT DIAGRAM

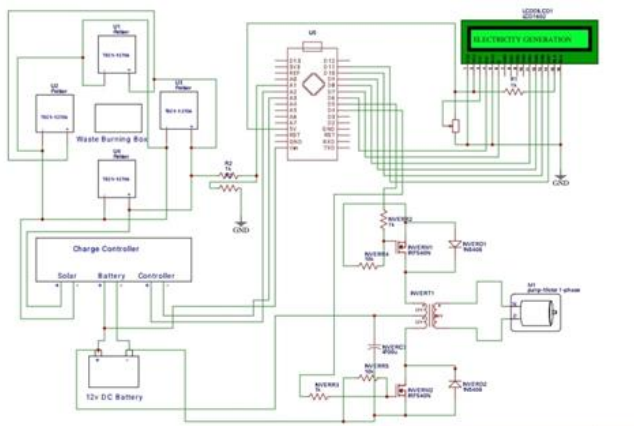

1. Waste Burning Section (Left Side)

- The block labeled “Waste Burning Box” burns solid waste.
- Around it, there are Peltier modules (TEC1-12706).
- These devices work on the temperature difference principle:

- One side is hot (from burning waste)
- Other side is cool

This generates DC electricity.

2. Power Generation & Collection

- Multiple Peltier modules (U1, U2, U3, U4) are connected together.
- Their output is combined to increase voltage/current.
- The generated electricity is sent forward in the circuit.

3. Charge Controller Section

- This block manages power flow:
 - Takes input from Peltier modules
 - Also supports solar input (hybrid system)
 - It:
 - Regulates voltage
 - Prevents overcharging
 - Safely charges the battery

4. Battery Storage

- A 12V DC battery stores the generated energy.
- This ensures:
 - Power is available even when no waste is burning.

5. Microcontroller Section (Center - Arduino)

- The main controller (looks like Arduino) controls the system.
- Functions:
 - Monitors voltage and system status
 - Controls switching (motor, inverter, display)
 - Sends data to LCD

6. LCD Display

- The LCD shows system status like:
 - “ELECTRICITY GENERATION”
 - Voltage / output info
 - Helps in monitoring the system easily

7. Inverter Circuit (Right Bottom)

- Components:
 - MOSFETs (IRF540N)
 - Transformer
 - Diodes (1N5408)
 - Function:
 - Converts 12V DC → AC voltage
 - Transformer steps up voltage to run AC load.

8. Motor / Pump Section

- A single-phase motor (pump) is connected.
- It is used for:
 - Agricultural irrigation
- Runs using converted AC power from inverter.

9. Protection & Supporting Components

- Resistors → control current
- Diodes → protect from reverse current
- Capacitor → smooth output

VII.HARDWARE DETAILS

1. Thermoelectric Plate TECI-1206:

A thermoelectric cooler is a solid-state heat pump that transfers heat from one side to the other when electric current flows through it.

It is based on the Peltier Effect and is sometimes called a Peltier cooler.

A TEC is made of many tiny pairs of p-type and n-type semiconductor pellets, connected: Electrically in series → so one DC power source drives all the pairs.

Thermally in parallel → so they share the same hot and cold plates.

The whole assembly is sandwiched between two thin ceramic plates for strength, insulation, and thermal conductivity.

- When DC current is applied: Electrons carry heat from one side (cold side) to the other (hot side). One plate gets cold, the other gets hot.
- By reversing the current, the direction of heat flow reverses the hot side becomes cold and vice versa.
- If no current is applied, heat flows normally by conduction (like any material).



Fig.1 Thermoelectric Plate

2 .Waste Burning Section:

This section converts solid waste into energy (thermal or electrical). The heat or energy generated here is distributed to SOLAR 1, 2, 3, 4, indicating a hybrid energy setup where solar and waste energy complement each other.



Fig.2 Waste Burning Section

3. Charge Control Buck Booster:

A buck-boost charge controller is an electronic device that regulates power from a variable DC source (like solar panels) to charge a battery.

It uses a buck-boost converter — a type of DC-DC converter — so it can:

- Step down (buck) the input voltage if it's higher than the battery voltage.
- Step up (boost) the input voltage if it's lower than the battery voltage.

This makes it ideal for systems where input voltage can fluctuate (cloudy day, changing solar panel output).

The converter switches between two modes very quickly (tens of kHz):

- When switch is ON: current builds up in the inductor, storing energy.
- When switch is OFF: energy is released to the output (battery).

By adjusting the duty cycle (time switch stays ON vs OFF), the controller regulates output voltage/current to safely charge the battery.



Fig.3 Charge Control Buck Booster

4. Battery:

A 12V 8Ah SLA battery is a rechargeable, maintenance-free, sealed lead-acid battery. It uses valve-regulated lead-acid (VRLA) technology, meaning it is spill-proof, can be used in any orientation, and does not require water top-ups.

Electrodes:

- Positive plate → Lead dioxide (PbO₂)
- Negative plate → Sponge lead (Pb)

Electrolyte: Dilute sulfuric acid (H₂SO₄), absorbed in glass mat (AGM type) or gel.

Sealed Housing: Prevents leaks, but has a safety valve to release excess gas in case of overpressure.

- During Charging: Current converts lead sulfate back to lead dioxide and sponge lead, restoring the battery.
- During Discharge: Lead dioxide and sponge lead react with sulfuric acid, producing lead sulfate and water — releasing electrical energy.



Fig.4 Battery

5. Arduino Nano:

The Arduino Nano is a compact, breadboard-friendly microcontroller board based on the ATmega328P (or ATmega168 in older versions). It is designed for small-scale projects and applications where space is a constraint, offering similar functionality to the larger Arduino Uno but in a miniature form factor.

- Microcontroller: Typically ATmega328P.
- Connectivity: Features 14 digital input/output pins (6 of which can be used as PWM outputs), 8 analog inputs, a USB interface (using a mini-USB port), and I2C
 - (A4/SDA and A5/SCL) capabilities.
- Power: Operates at 5V, with an input voltage range of 6V to 20V (recommended 7V to 12V).

- Memory: Offers 32 KB of Flash memory, 2 KB of SRAM, and 1 KB of EEPROM (for ATmega328P).
- Programming: Programmed using the Arduino Integrated Development Environment (IDE).
- Applications: Ideal for projects requiring a small footprint, such as wearables, robotics, and embedded systems.
- Successor: The Arduino Nano Every is a more powerful, pin-compatible successor to the traditional Arduino Nano, featuring an ATmega4809 processor and a micro-USB connector.

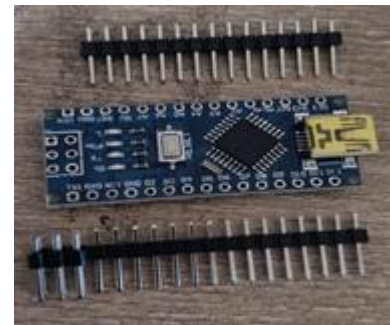

Fig.5 Arduino Nano

6. MOSFET-PS55n:

MOSFET stands for Metal–Oxide–Semiconductor Field-Effect Transistor. It is one of the most widely used transistors in electronics — especially for switching and amplification.

A MOSFET has three terminals (sometimes four):

- Gate (G): Input terminal that controls conduction.
- Drain (D): Output terminal where current flows out.
- Source (S): Terminal where current enters.
- (Optional) Body (B): Usually connected internally to Source.

Inside, there's a semiconductor channel (N-type or P-type) whose conductivity is controlled by an electric field applied via the Gate.

The Gate is insulated from the channel by a thin oxide layer → very high input impedance (almost no current needed to control it).

When a voltage is applied between Gate and Source (V_{GS}), it creates an electric field. This field enhances or depletes the channel, allowing current to flow between Drain and Source. This means a small voltage on Gate controls a large current through Drain– Source making it a great switch.

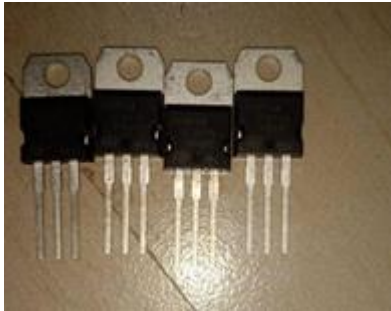

Fig.6 MOSFET-PS55n



Fig.7 AC Pump

7. AC Pump:

The Elove 40Watt Submersible Water Pump, a versatile pump designed for various applications such as desert air coolers, aquariums, fountains, and hydroponic systems.

- Power and Voltage: Operates at 40 watts and is compatible with 220-240V/50 Hz power supplies, making it suitable for households looking to manage electricity consumption.
- Performance: Offers a high flow rate (e.g., 3200 L/H as seen in a similar product description) and can lift water to a significant height (e.g., up to 2.5 meters or 8.5 feet approx. for a similar product).

Features a compact design, making it easy to integrate into various setups like aquariums or ponds. Constructed with durable materials, often sturdy ABS, and designed for longevity. Includes features for efficient heat dissipation to maintain optimal operating temperatures. Detachable and cleanable design allows for easy maintenance without requiring special tools.

Safe for aquatic life, as it typically features no exposed copper and is oil-free. Known for its ultra-quiet operation, ensuring a peaceful environment. Widely used in small to medium-sized desert coolers, ponds, waterfalls, and irrigation systems.

8. Resistor:

A resistor is a passive electronic component that resists the flow of electric current, creating a voltage drop according to Ohm's Law:

$$V = I \times R$$

Resistors are made from materials with controlled resistance, such as:

Carbon film (cheap, general purpose), Metal film (precise, low noise), Wire-wound (high power rating), Thick/Thin film on ceramic (surface mount resistors). They usually have two leads (through-hole) or terminals (SMD).

Most resistors use color bands to indicate resistance value:

- 1st Band = First digit
- 2nd Band = Second digit
- 3rd Band = Multiplier
- 4th Band = Tolerance (if present)

A resistor converts some of the electrical energy into heat while controlling current flow. Connect a resistor in series with an LED → limits current to protect the LED.

1. Fixed Resistors: Carbon film, metal film, wire-wound. Have a single, fixed resistance value.
2. Variable Resistors: Potentiometer (adjustable voltage divider). Rheostat (adjustable current limiter)
3. Special Types: LDR (Light-Dependent Resistor) changes resistance with light. Thermistor changes resistance with temperature. Fusible Resistor acts as a fuse when overloaded



Fig.8 Resistor

9. IN4007 Diode:

A diode is a two-terminal semiconductor device that allows current to flow in one direction only and blocks it in the opposite direction. It acts like a one-way valve for electricity. A basic diode is made by joining P-type and N-type semiconductor material → forming a PN junction.

- Anode (A): Connected to P-type material
- Cathode (K): Connected to N-type material

The cathode is usually marked with a band/strip on the diode body.

Forward Bias: When the anode is more positive than cathode ($V > \sim 0.7V$ for silicon diodes), the diode conducts current.

Reverse Bias: When the anode is negative w.r.t. cathode, the diode blocks current (except for a very tiny leakage current).

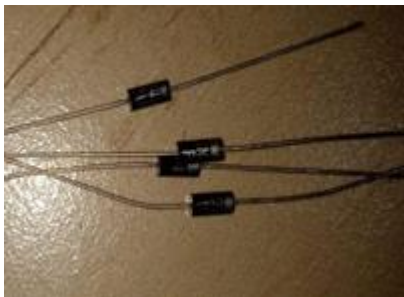

Fig.9 IN4007 Diode

10. Capacitor:

A capacitor is a passive electronic component that stores electrical energy in an electric field and releases it when needed. It resists changes in voltage making it useful for filtering, energy storage, and timing circuits.

A capacitor consists of Two conductive plates (metal foil or film). Dielectric (insulating material) between the plates (air, ceramic, plastic, mica, or electrolytic material). When a voltage is applied across the plates, electric charge accumulates, storing energy.



Fig.10 Capacitor

11. Red LCD:

A Red LCD is a liquid crystal display that shows characters or graphics using red-colored segments or pixels. Usually used in digital clocks, meters, thermometers, calculators, or single-color indicators.

The red color is achieved using either:

- Red filter layer in the LCD
- Red backlight (LED) behind the liquid crystal layer

A Red LCD has the same basic layers as standard LCDs, with modifications to produce red display:

1. Liquid Crystal Layer – molecules control light transmission.
2. Red Filter / Red Backlight – allows only red light to pass, giving the display its color.
3. Glass Substrates – support and encapsulate the liquid crystals.
4. Polarizers – control light polarization.
5. Electrodes – transparent electrodes apply voltage to segments or pixels.
6. Driver / Controller IC controls which segments light up based on input signals.



Fig.11 Red LCD

12 .Trimpot Potentiometer:

A trimpot (short for trimming potentiometer) is a small adjustable resistor used for calibration and fine-tuning in electronic circuits. Essentially, it's a variable resistor designed to be adjusted infrequently, usually during setup or maintenance.

Unlike regular potentiometers, trimpots are not meant for user interaction in normal operation.

- Resistive Track: Carbon film, cermet, or conductive plastic
- Wiper / Slider: Adjustable contact moves along the track
- Terminals: Usually 3 terminals – two ends of the resistor + wiper
- Adjustment Mechanism: Small screw, slot, or multi-turn screw for precise setting Trimpots come in through-hole (TH) or surface-mount (SMD) packages.

1. Three-Terminal Trimpot: End terminals: Connected to the resistive track ends. Wiper terminal: Moves along the track, outputting adjustable voltage or resistance
2. Two-Terminal Use: Can be used as a variable resistor (rheostat) by connecting one end and wiper
3. Adjustment: Turn screw/slot to increase or decrease resistance
4. Multi-turn trimpots allow very fine control over resistance



Fig.12 Trimpot Potentiometer

13. Current Sensor:

A current sensor is an electronic device that measures the flow of electric current in a conductor and converts it into a measurable voltage or digital signal. Used for monitoring, protection, and control of electrical systems. Can measure AC, DC, or both types of current.

Current sensors work based on one of several physical principles:

1. Resistive (Shunt) Method

A low-value resistor is placed in series with the load.

Voltage drop across the resistor ($V = I \times R$) is proportional to current.

2. Hall Effect Method

Uses the Hall effect sensor to detect magnetic field around a conductor. Non-contact, galvanically isolated measurement.

3. Current Transformer (CT)

For AC only. Measures current by producing a proportional secondary current in a transformer coil.

4. Rogowski Coil

Measures AC current without contact. Flexible, ideal for high currents.



Fig.13 Current Sensor

14 .Transformer:

A 12-0-12 V, 5 A center-tapped step-down transformer
 Primary Voltage: Usually 220–240 V AC (depends on region)
 Secondary Voltage: 12-0-12 V AC (center-tapped)
 Current Rating: 5 A (maximum load on secondary)
 Power Rating: (for total secondary power) So, this is roughly a 120 VA transformer.

1. **Center Tap:** The secondary has three terminals: +12 V, 0 V (center), -12 V. Useful for creating dual-polarity power supplies (+12 V, 0 V, -12 V) or full-wave rectifier circuits.
2. **Step-Down:** Converts high-voltage AC from mains (e.g., 230 V) to low-voltage AC suitable for electronics.
3. **Current Capability:** Rated at 5 A, meaning the transformer can safely provide up to 5 A per leg (± 12 V) continuously without overheating.
4. **Construction:** Usually laminated iron core for efficiency. Wire gauge sized to handle 5 A without excessive heat.



Fig.14 Transformer

15. LCD Display:

A 16x2 character LCD (Liquid Crystal Display) module, specifically identified as a JHD 162A model, featuring a green backlight and black text.

- **Type:** Alphanumeric LCD, capable of displaying both letters and numbers.
- **Capacity:** It can display 16 characters per line and has 2 lines, totaling 32 characters.
- **Backlight:** Equipped with a vibrant green LED backlight to enhance visibility in various lighting conditions.
- **Controller:** Utilizes the common HD44780 compatible controller, making it easily interfaceable with microcontrollers like Arduino, Raspberry Pi, STM32, PIC, and AVR.
- **Applications:** Widely used in DIY electronics, robotics, embedded systems, home automation, industrial control panels, and for displaying sensor data or debug information.
- **Features:** Includes a contrast adjustment potentiometer and can be used in both 4-bit and 8-bit modes.

Fig.15 LCD Display

VIII.BENEFITS

- **Environment-Friendly** – lowers greenhouse gas emissions.
- **Ensures Reliable Irrigation** – uninterrupted power for pumps.
- **Improves Soil Health** – provides nutrient-rich bio-fertilizer.
- **Cost Savings** – cuts electricity and diesel expenses.
- **Cleaner Communities** – promotes better hygiene and sanitation.
- **Job Creation** – employment in collection, operation, and maintenance.
- **Promotes Circular Economy** – converts waste into energy and resources.
- **Supports Sustainable Farming** – boosts productivity with eco-friendly practices.

IX.SCOPE OF THE STUDY

- **Assessment of Waste Generation:** Study the quantity and type of solid waste available (organic, recyclable, inert) in the target area to evaluate its potential for energy production.
- **Technology Selection:** Identify and compare suitable waste-to-energy technologies (e.g., anaerobic digestion, biogas engine, gasifier) for optimal power generation.
- **System Design & Integration:** Design an integrated system that collects, processes, and converts waste into renewable energy, then connects it to agricultural pumps for irrigation.
- **Energy Utilization Analysis:** Estimate power generation capacity, pump operating hours, and potential savings in grid power or diesel consumption.
- **Environmental Impact Study:** Analyze reduction in landfill waste, greenhouse gas emissions, and improvement in soil health through digestate use.
- **Economic Feasibility:** Evaluate the cost of installation, operation, maintenance, and payback period compared to conventional energy sources.
- **Social & Community Benefits:** Study the impact on local communities, including job creation, sanitation improvement, and awareness about waste segregation.
- **Scalability & Future Expansion:** Explore the potential for scaling the system to larger capacities or replicating it in other rural/agricultural regions.

X.ADVANTAGES

- Cost-Effective Solution: Reduces farmers' dependence on expensive diesel or grid electricity for irrigation.
- Waste Reduction: Minimizes landfill waste by efficiently utilizing organic waste for energy production.
- Environmental Protection: Lowers greenhouse gas emissions and prevents soil and water pollution caused by improper waste disposal.
- Resource Recovery: Produces nutrient-rich bio-slurry that can be used as an organic fertilizer, improving soil fertility.
- Energy Independence: Promotes self-sufficiency in rural communities by offering decentralized power generation.
- Employment Opportunities: Creates jobs in waste collection, segregation, and biogas plant operations.
- Sustainability: Supports the circular economy by turning waste into a valuable resource for energy and agriculture.

XI.DISADVANTAGES

- High Initial Investment: Setting up a biogas plant and power generation unit requires significant capital, which may not be affordable for small farmers without subsidies.
- Skilled Operation & Maintenance: The system requires trained personnel for proper operation, regular maintenance, and troubleshooting.
- Feedstock Dependency: Continuous and adequate supply of biodegradable waste is essential; seasonal variations in waste generation may affect energy output.
- Space Requirement: Installation of biogas digesters and storage units requires land, which may be limited in densely populated or small farming areas.
- Technical Challenges: Gas leakage, digester failure, or low biogas yield can occur if the system is not designed or maintained properly.
- Odor & Hygiene Issues: Improper handling of waste or digestate can lead to foul smell and health concerns.
- Economic Viability: Payback period can be long without financial incentives, making it less attractive to farmers with low income.
- Dependency on Community Participation: Success depends on consistent waste segregation, collection, and cooperation from the local community.

XII.APPLICATIONS

- Agricultural Pumping: Reliable electricity generation from biogas can be used to power irrigation pumps, reducing dependency on grid power and diesel generators.
- Waste-to-Energy Conversion: Converts biodegradable waste into clean energy, reducing landfill waste and minimizing environmental pollution.
- Sustainable Farming: Produces nutrient-rich slurry as a by-product, which can be used as organic fertilizer, enhancing soil health and crop yield.
- Community Waste Management: Offers a decentralized solution for effective waste collection, segregation, and treatment at the local level.
- Greenhouse Gas Reduction: Helps in reducing methane emissions from open dumping of organic waste, contributing to climate change mitigation.
- Economic Benefits: Creates job opportunities in waste collection, plant operation, and maintenance, while reducing electricity costs for farmers.

XIII.FINAL RESULT

1. Final Result and System Performance:

Waste Combustion – Heat Energy- TEG(DC Power)- Inverter- AC Motor

Thermal Conversion Efficiency: achieve a consistent temperature difference (Delta T).if the hot side is 98C and the cold side is 20C, the efficiency of the plates will likely be around 5

- Hot side temperature = 98 °C
- Cold side temperature = 20 °C

$$\Delta T = T_H - T_C \\ = 98 - 20 \\ = 78 \text{ } ^\circ\text{C}$$

Where,

TH=Thermoelectric Plate Hot Side

TC=Thermoelectric Plate Cold side

Delta t=Temperature difference

- AC Synchronization: The inverter successfully converted the DC output into run the 40W motor without overheating it.
- Agricultural Output: The "Integrated" part of our project results in Bio-ash. This byproduct should be analyzed as a potassium-rich soil additive for agricultural use.

Summary Table:

Hot side	Cold side	Delta t	Power
98C	20C	78C	40W

2. Critical Observations Required

- **Seeback Coefficient Calculation:**
 Seeback coefficient $\approx 8-10 \text{ mV}/^\circ\text{C}$ per module
 $S=9\text{Mv}/^\circ\text{C}$
 $V=S \times \Delta T$
 $=9 \times 78$
 $=702\text{mV} \approx 0.7\text{V}$
 For example :
 If 2 mv is produced for 1°C
 Then $S=2\text{mv}/^\circ\text{C}$

Inverter Efficiency: Measure the DC power input to the AC power output to the motor.

$$\text{Efficiency} = \text{PAC} / \text{PDC} * 100$$

I. Measure DC Input Power

- DC Voltage = VDC
- DC Current = IDC
- $\text{PDC} = \text{VDC} \times \text{IDC}$
 - VDC=12V
 - IDC=4.6A

$$\text{PDC} = 12 \times 4.6 = 55.2\text{W}$$

II. Measure AC Output Power

$$\text{PAC} = \text{VAC} \times \text{IAC} \times \cos \phi$$

$$\text{VAC} = 230\text{V}$$

$$\text{IAC} = 0.22\text{A}$$

$$\text{Power factor } \cos \phi = 0.8$$

$$\text{PAC} = 230 \times 0.22 \times 0.8 = 40.48\text{W}$$

III. Efficiency Calculation

$$\eta = 40.48 / 55.2 \times 100$$

$$\eta \approx 73.3\%$$

- **Thermal Saturation Point:** Observe the time it takes for the heat sink to saturate. Once the cold side gets too hot, the voltage will drop and the motor will slow down
- **Voltage Regulation:** Observe if the voltage drops significantly when the 40W load is

Summary Table:

Seeback Coefficient	2MV
DC Voltage	12V
DC Current	4.6 Amp
DC Power	55.2W
AC Voltage	230V
AC Current	0.22 Amp
AC Power	40.48W
Efficiency	73.3%

3. Electrical Generation Capacity (Detailed)

Running a 40W AC motor more demanding than a DC motor because of the losses in the Inverter To provide 40% of AC power, our heat plates must actually generate about 50W-65W of DC power

A. Voltage and Current (DC Side Before Inverter)

To feed a standard inverter , you will likely need a 12V or 24V DC bus

- Voltage: 12Vto14VDC
- Current:

$$\text{IDC} = \text{Required Power Voltage}$$

$$= 55 / 12\text{V}$$

$$= 4.58 \text{ Amps}$$

Requirement: you will need several TEG modules connect in a Series network to achieve nearly 0.22 Amps.

B. Voltage and Current (AC Side - Motor Terminals)

- Voltage: 230V AC 110V depending on your local motor rating
- Frequency: 50Hz(Standard)
- Current: For a 40W motor at 230V:

$$\text{IAC} = \text{P} / \text{V} \cos \Phi$$

$$= 40\text{W} / 230 * 0.8$$

$$= 0.22 \text{ Amps}$$

4. Technical Summary Table:

Component	Parameter	Expected Value
Heat Source	Solid Waste Burning	80C-100C
Generation	TEG Array Output	55W DC
Inverter	DC to AC Converter	12V DC to 230V AC
Load (Motor)	Rated Power	38-40W
AC Current	Running Current	0.22A
Agricultural	By Product	Organic Bio-ash /Biochar

XIV.CONCLUSION

The Integrated Solid Waste Management System for Renewable Energy and Powering Agricultural Pump Usage offers a sustainable solution to two major challenges effective waste disposal and reliable energy supply for agriculture. By converting biodegradable waste into biogas through anaerobic digestion, this system not only generates renewable energy but also provides nutrient-rich slurry that enhances soil fertility. The electricity produced can be used to run agricultural pumps, reducing dependence on grid electricity and diesel generators, which lowers operating costs for farmers and decreases carbon emissions. This approach contributes to waste minimization, circular economy practices, and rural energy security, making it a practical and eco-friendly model for rural development. With proper implementation, community participation, and support from government policies, the system has the potential to improve agricultural productivity, promote sustainable farming practices, and create local employment opportunities.

REFERENCES

1. A. Zafar, S. Ahmad, and M. Khan, "Optimizing dry waste incineration for energy recovery: Heat generation and environmental impact," *Waste Management Journal*, vol. 45, no. 7, pp. 12-23, 2021.
2. X. Zhang, J. Liu, and Y. Wang, "Thermoelectric generators in waste-to-energy systems: Applications and advancements," *Renewable Energy Research Journal*, vol. 38, no. 4, pp. 1125-1136, 2019.
3. Q. Chen, R. Huang, and L. Zhao, "Performance evaluation of TEC 12706 Peltier modules for energy harvesting," *Journal of Thermoelectric Research*, vol. 54, no. 9, pp. 1021-1029, 2020.
4. D. Lopez, A. Martinez, and P. Garcia, "Environmental and economic assessment of waste-to-energy systems: A comparative study," *Energy and Environment Journal*, vol. 61, no. 2, pp. 145-158, 2022.
5. J. D. Smith, L. M. Brown, and R. J. White, "Automated Waste Segregation System Using Arduino Uno R3," *Journal of Environmental Engineering and Automation*, vol. 12, no. 3, pp. 45-52, 2021.
6. P. S. Patel, V. Kumar, and S. Roy, "Eco Sort - Dry and Wet Waste Separator Using Arduino," *International Journal of Sustainable Waste Management*, vol. 15, no. 4, pp. 123-130, 2022.
7. A. S. Rao, K. P. Singh, and M. G. Nair, "Automatic Waste Segregator," *International Journal of Waste Management and Recycling*, vol. 10, no. 2, pp. 67-74, 2020.
8. Tchobanoglous, G., Theisen, H., & Vigil, S. (1993). *Integrated Solid Waste Management: Engineering Principles and Management Issues*. McGraw-Hill International Editions.
9. Sharholy, M., Ahmad, K., Mahmood, G., & Trivedi, R.C. (2008). "Municipal solid waste management in Indian cities – A review." *Waste Management*, 28(2), 459–467. <https://doi.org/10.1016/j.wasman.2007.02.008>
10. Singh, R.P., Tyagi, V.V., Allen, T., Ibrahim, M.H., & Kothari, R. (2011). "An overview for exploring the possibilities of energy generation from municipal solid waste (MSW) in Indian scenario." *Renewable and Sustainable Energy Reviews*, 15(9), 4797–4808. <https://doi.org/10.1016/j.rser.2011.07.071>
11. UNEP (2016). *Global Waste Management Outlook*. United Nations Environment Programme. Retrieved from <https://www.unep.org/resources/report/global-waste-management-outlook>
12. Ministry of New and Renewable Energy (MNRE), Government of India. (2023). *Waste to Energy Programme – Guidelines and Reports*. Retrieved from <https://mnre.gov.in>
13. Rada, E.C., Ragazzi, M., & Fedrizzi, P. (2013). "Energy recovery from MSW in the EU: A review of actual situation." *Waste Management*, 33(6), 1343–1358.
14. Gupta, S., Mohan, K., Prasad, R., Gupta, S., & Kansal, A. (1998). "Solid waste management in India: Options and opportunities." *Resources, Conservation and Recycling*, 24(2), 137–154.
15. ISWA (2020). *Waste-to-Energy State-of-the-Art Report*. International Solid Waste Association. Retrieved from <https://www.iswa.org>